

SEE WHAT PEERLESS CAN DO FOR YOU.

FOR HIGH-EFFICIENCY, HIGH-CAPACITY, AND
LOW-COST GAS AND LIQUID SEPARATION

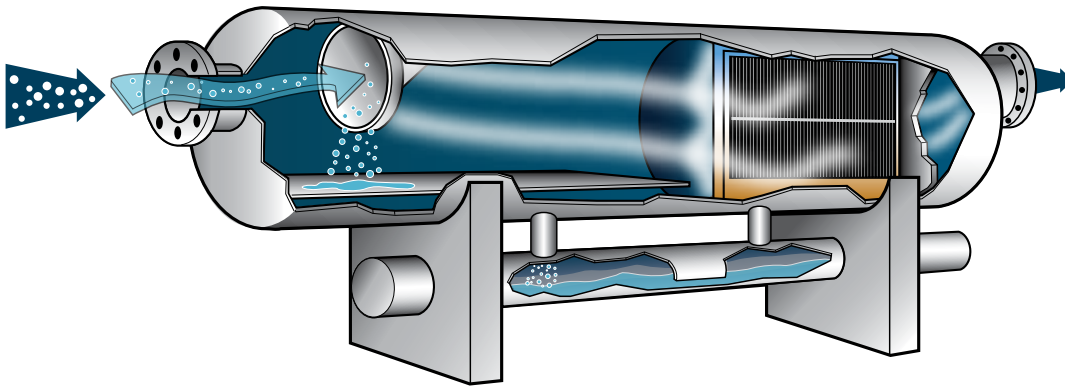

HORIZONTAL SEPARATOR
FOR HANDLING HIGH LIQUID RATES
AND LARGE SLUGS.

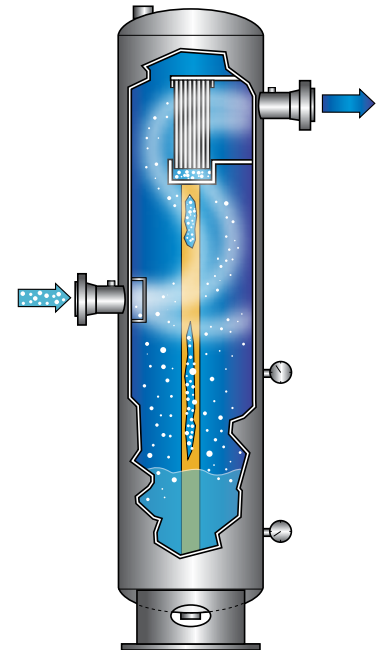

VERTICAL SEPARATOR
FOR SLUG REMOVAL APPLICATIONS AND
SMALL FOOTPRINT INSTALLATIONS.

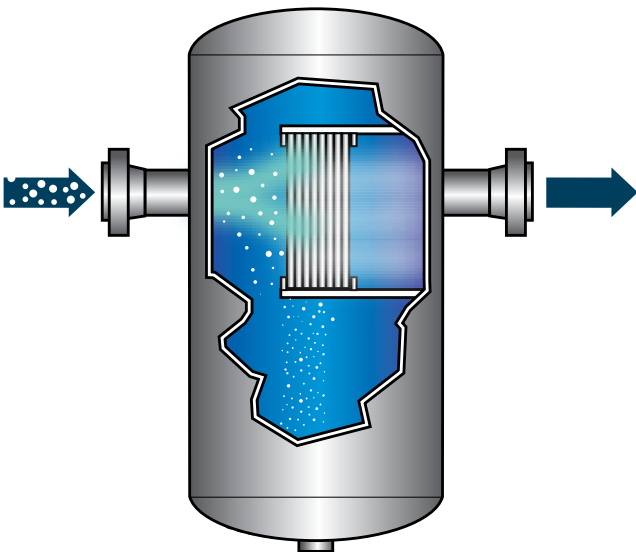

LINE SEPARATOR
FOR APPLICATIONS WITH SPACE AND
PIPING LIMITATIONS.

TYPICAL APPLICATIONS:

- GAS TRANSMISSION AND METERING
- FUEL GAS CONDITIONING
- OIL MIST REMOVAL
- CHEMICAL PLANTS
- AMMONIA AND UREA PLANTS
- DESICCANT BED PROTECTION
- MOLECULAR SIEVE PROTECTION

- FLEXIBLE SEPARATOR DESIGNS
- HIGH-CAPACITY VANES
- GUARANTEED PERFORMANCE
- BUILT TO ASME CODE FOR INTERNATIONAL STANDARDS

HORIZONTAL SEPARATORS

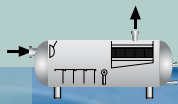

PEERLESS...COMBINING INNOVATION WITH EXPERTISE IN SEPARATOR DESIGN AND FABRICATION.



PEERLESS SINGLE BARREL SEPARATORS SERVE EFFECTIVELY AS LIQUID SLUG-CATCHERS AND PERFORM ESPECIALLY WELL IN 3-PHASE APPLICATIONS.

SINGLE BARREL GAS SEPARATOR

- High efficiency liquid removal
- Wide liquid handling operating range, including slug
- Extremely high gas throughput
- Customized for 3-phase flow applications
- Large liquid retention volume

FEATURES

These separators are designed to provide efficient liquid removal at high gas flow capacities. They effectively handle large liquid slugs and are easily applied to 3-phase separation.

PRINCIPLE OF OPERATION

- (A) Gas and liquid entering vessel are diverted by inlet baffle to remove slugs and bulk liquids.
- (B) Liquid falls to vessel bottom through quieting plates into first sump.
- (C) Gas and remaining mist enter vane separator
- (D) Remaining liquid collected at bottom of vane pack is drained by down comer pipes
- (E) Submerged down-comer pipes and seal pots result in optimal drainage
- (F/G) Drains and liquid level controllers ensure proper liquid discharge out of vessel.

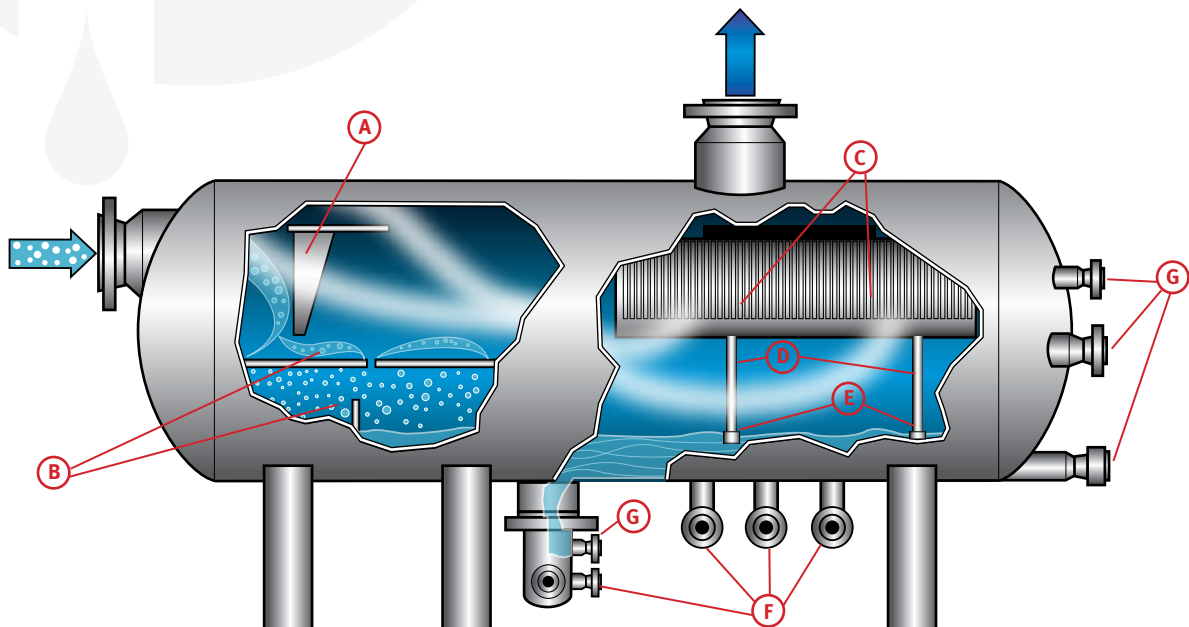

HORIZONTAL SINGLE-BARREL SEPARATOR

Innovative Designs
Cost Effective Retrofits
Guaranteed Performance

PRODUCT PERFORMANCE GUARANTEE

Peerless Horizontal Slug Catcher Separators are guaranteed to remove 100% of all liquid droplets 8 microns and larger. The outlet gas will contain no more than 0.10 gallon of entrained liquid per MMSCF at maximum rated capacity.

HORIZONTAL SEPARATORS

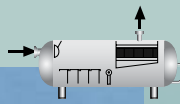

PEERLESS DOUBLE-BARREL SLUG-CATCHERS EFFICIENTLY REMOVE BULK LIQUIDS FROM HIGH GAS FLOWS.

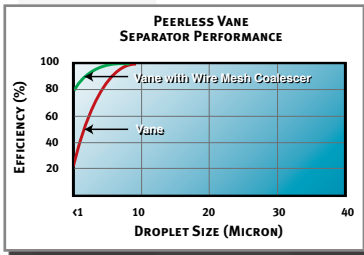

DOUBLE-BARREL SEPARATOR

- High-efficiency liquid slug removal
- No liquid re-entrainment
- Extremely high gas throughput
- Lower barrel acts as a quiet retention chamber

PRINCIPLE OF OPERATION

- (A) Gas and liquid entering vessel are diverted by inlet baffle to remove slugs and bulk liquids.
- (B) Liquid drains into lower barrel through first down-comer tube.
- (C) Gas and remaining mist enter vane separator.
- (D) Remaining droplets collected at bottom of vane pack drain into lower barrel through second down-comer tube.
- (E) Split lower barrel with two sets of liquid level controllers offer proper discharge out of the lower barrel.

FEATURES

Double-Barrel Separators are designed to provide efficient liquid removal. Additionally, they can achieve higher gas-flow capacities through the longitudinal arrangement of separation elements in the upper barrel. The lower barrel gets the separated liquid away from the gas flowing in the upper barrel, thus eliminating re-entrainment. Additionally, the lower barrel acts as a retention chamber that provides residence time for gas bubbles to emerge from the liquid.

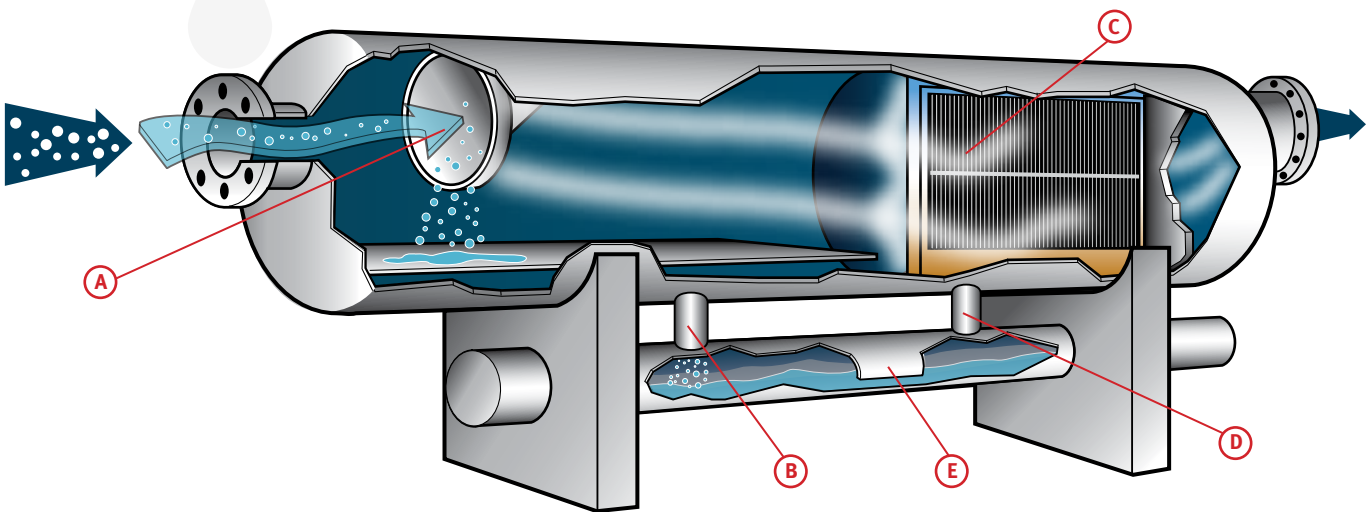

HORIZONTAL DOUBLE-BARREL SEPARATOR

PRODUCT PERFORMANCE GUARANTEE

Peerless Double Barrel Slug Catcher Separators are guaranteed to remove 100% of all liquid droplets 8 microns and larger. The outlet gas will contain no more than 0.10 gallon of entrained liquid per MMSCF at maximum rated capacity.

VERTICAL SEPARATORS

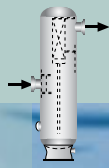

PEERLESS VERTICAL GAS SEPARATORS OPERATE IN GAS PLANTS, REFINERIES, PETROCHEMICAL PLANTS, AND OTHER APPLICATIONS WHERE THE VESSEL FOOTPRINT MUST BE MINIMIZED.

VERTICAL GAS SEPARATOR BENEFITS

- High-efficiency liquid removal from gas streams
- Broad operating range
- Effective slug removal
- Minimal footprint
- High and low liquid:gas ratios compatibility
- Available as a retrofit to existing vertical separators

PRINCIPLE OF OPERATION

- (A) Gas and liquid entering vessel are diverted by inlet baffle to remove slugs and bulk liquids.
- (B) Gas and remaining mist enter vane separator.
- (C) Removed liquid collects at vane bottom.
- (D) Submerged down-comer pipe drains liquids to bottom of vessel.
- (E) Liquid-level controls monitor collected liquid amounts for proper liquid discharge out of the vessel.

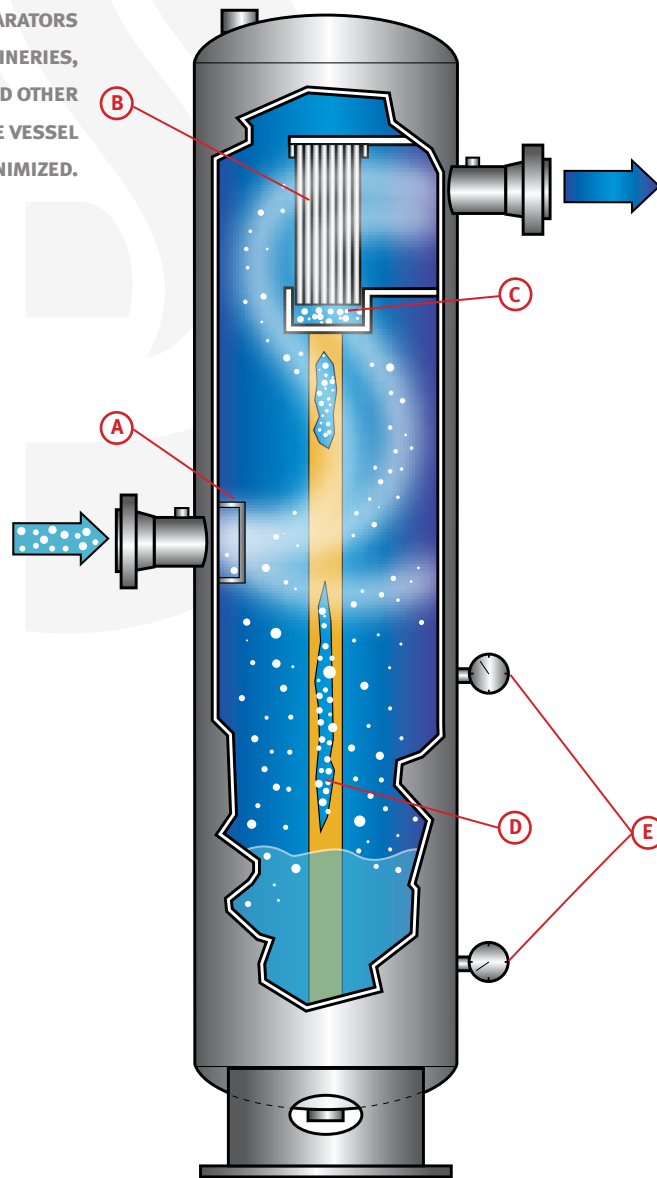

FEATURES

Peerless Vertical Gas Separators are designed to handle both high and low liquid-to-gas ratios. They are especially recommended for applications where heavy liquid entrainment causes a slugging problem. Peerless Proprietary devices provide smaller vessel configurations when compared to mesh- pad or other separation devices.

VERTICAL GAS/LIQUID SEPARATOR

PRODUCT PERFORMANCE GUARANTEE

Peerless Vertical Gas Separators are guaranteed to remove 100% of all liquid droplets 8 microns and larger. The outlet gas will contain no more than 0.10 gallon of entrained liquid per MMSCF at maximum rated capacity.

LINE SEPARATORS

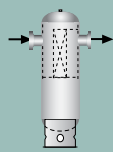

LINE SEPARATOR



VARI-LINE™ SEPARATORS

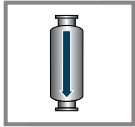

FIGURE A

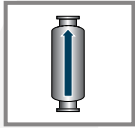

FIGURE B



FIGURE C



FIGURE D

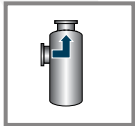

FIGURE E

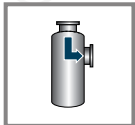
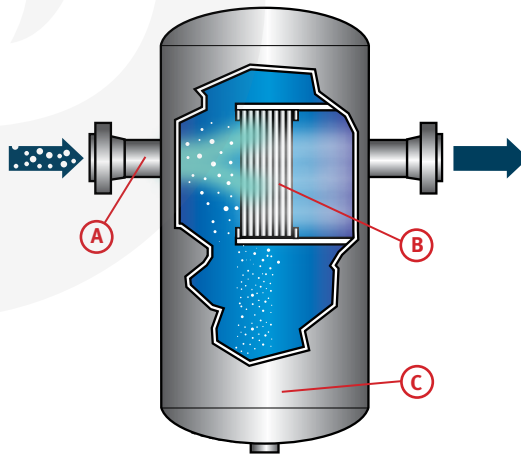

FIGURE F

Can be designed for operating pressures in excess of 1500 psi, Peerless has fabricated several at design pressures in excess of 20,000 psi. Pressure drop across the separator is very low.

PRINCIPLE OF OPERATION

- (A) Gas with entrained liquid enters the vessel where the gas expands and enters the inertial vane mist extractor.
- (B) The gas is subjected to multiple changes in direction as it flows through the vane passages. The entrained liquid droplets are forced to contact the vane walls where they impinge and form a film. The liquid film moves into vane pockets, sheltered from the gas flow.
- (C) The liquid is then drained by gravity to the liquid reservoir in the bottom of the vessel out of the main gas stream.



STANDARD LINE SEPARATOR

Peerless Standard Line Separators provide a direct, straight through design most typically used in plant air or gas systems. Body diameters from 6 - 5/8" to 20" and ratings up to 740 psi are available from stock.

CUSTOM-DESIGNED

VARI-LINE™ SEPARATORS

For applications where space is at a premium and piping limitations prevent the use of a straight-through line separator, Peerless VARI-LINE Separators are designed with several nozzle configurations. Internal baffling permits nearly any combination of inlet and outlet connection locations (see figures A – F).

LINE SEPARATOR BENEFITS

- Efficient removal of liquids from gas streams
- Ideal for limited space installations
- Negligible pressure drop
- Wide range of gas capacities and pressure ratings
- Stock or custom (VARI-LINE) designs

PERFORMANCE GUARANTEE

Peerless Line Separators are guaranteed to remove 100% of all liquid droplets 8 microns and larger. The outlet gas will contain no more than 0.10 gallon of entrained liquid per MMSCF at maximum rated capacity.

VANE ELEMENTS AND ASSEMBLIES

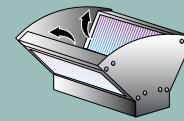
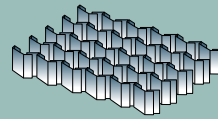

CONSULT A PEERLESS SPECIALIST FOR YOUR SEPARATION REQUIREMENTS: NEW CONSTRUCTION AND RETROFIT

VANE PROFILES

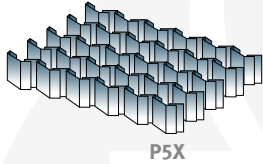

P5X

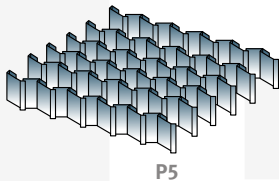

P5



P6X

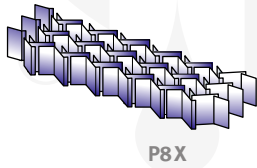

P8X

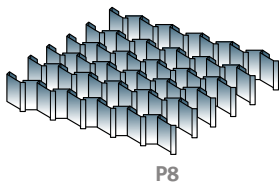

P8

Frequently used vane profiles comprising three double-pocket and single-pocket designs.

PRINCIPLE OF OPERATION

- (A) Contaminated gas entering the vane unit is directed into adjacent vertical channels where each one subjects the gas to rapid multiple changes in direction.
- (B) Inertial forces resulting from rapid direction change force liquid droplets against vane walls. Liquid droplets coalesce on the vane wall surface.
- (C) Gravity, surface tension, and momentum drive coalesced liquid into the vane pockets. Liquid flows down the pockets and collects in liquid reservoir.
- (D) Clean gas exits the tail end of the vane pack.

SPECIAL FEATURES

Peerless Vane Separators can be configured to meet the needs of special applications, including:

- Fixed or removable vane elements
- Welded or bolted frameworks
- Wash systems
- Multi-stage systems
- Flow distribution manifolds
- Retrofit Kits

VANE PROFILES

Peerless Vane Elements are available in several high-performance profiles. Peerless specifies the correct vane profile for each application.

CROSS SECTIONAL VIEW OF PEERLESS VANE ELEMENT

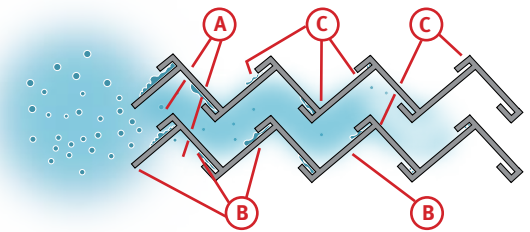

MIST EXTRACTOR CONFIGURATIONS

Vane elements of a specific profile are assembled into one of four major configurations: single-bank, double-bank, four-bank and eight-bank. Configurations are selected to match specific applications. Special designs can be developed for unique operational situations such as performance enhancement or retrofits. Several typical configurations are illustrated.

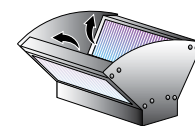

DOUBLE V BANK

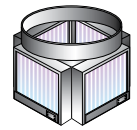

FOUR BANK

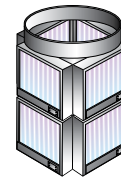

EIGHT BANK

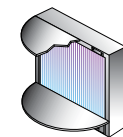

SINGLE BANK