

Instruction Manual

CVS Type 667 Diaphragm Actuator Sizes 30-70

All CVS Controls actuators are to be installed and maintained in accordance with instructions supplied by CVS Controls.

This manual includes information on installing, maintaining and adjusting the CVS Type 667 Actuator, sizes 30 to 70. Part numbers for the entire assembly is also included. For information on other equipment used with these actuators, consult the appropriate manuals.

Introduction

The CVS 667 is a reverse-acting, spring-opposed diaphragm actuators providing 3-inches (76 mm) of maximum travel. Although typical pressure ranges are 3 to 15 psi or 6 to 30 psi, additional pressure ranges are available upon request. The CVS Type 667 Actuator is used for automatic operation of control valves, effective in applications where throttling or on/off service is required.

The actuator positions the valve plug in the valve in direct response to the varying loading pressure on the actuator diaphragm. When the signal pressure increases to the lower diaphragm casing, the actuator stem is forced upward, compressing the spring. When the signal pressure is reduced, the spring moves the actuator stem in the downward direction. If the signal pressure should fail, the spring will force the stem downward, providing "fail-closed action" for "push down to close" valves.



Figure 1: CVS Type 667 Actuator

Specifications

Refer to Table 1 for specifications for the CVS Type 667 Actuator, and to the nameplate on your actuator for settings specific to your equipment.

It is important not to exceed the Maximum Diaphragm Pressure as listed in Table 1 when the actuator is set at less than full travel. If this pressure is exceeded before the travel stop comes in contact with the upper diaphragm plate, the maximum allowable valve stem load may be exceeded.

The Maximum Excess Diaphragm Pressure as listed in Table 1 is the pressure that can be added when the actuator is set at full travel. The sum of the pressure which is required to fully stroke the valve and the excess pressure added when the actuator is against the stop must not exceed the "Maximum Diaphragm Casing Pressure" as outlined in Table 1.

Head Office
3900 – 101 Street
Edmonton, Alberta, Canada T6E 0A5
Office: (780) 437-3055
Fax: (780) 436-5461

CVS
CONTROLS

Calgary Sales Office
3516 – 114 Avenue SE
Calgary, Alberta, Canada T2Z 3V6
Office: (403) 250-1416
Fax: (403) 291-9487

Website: www.cvs-controls.com E-Mail: info@cvs-controls.com

Table 1: CVS Type 667 Diaphragm Actuator Specifications

Specification		Actuator Size								
		30	34	40	45	46	50	60	70	
Nominal Effective Area	Sq. In.	46	69	69	105	156	105	156	220	
	Sq. cm	297	445	445	677	1006	677	1006	1419	
Yoke Boss Size Diameter	In.	2-1/8	2-1/8	2-13/16	2-13/16	2-13/16	3-9/16	3-9/16	3-9/16	
	mm	54	54	71	71	71	90	90	90	
Valve Stem Size	In.	3/8	3/8	1/2	1/2	1/2	3/4	3/4	3/4	
	mm	9.5	9.5	12.7	12.7	12.7	19.1	19.1	19.1	
Max. Allowable Output Thrust	Lbs	2300	2300	2700	5650	7550	5650	6800	8800	
	N	10,230	10,230	12,010	25,131	33,582	25,131	30,246	39,142	
Maximum Travel ²	Standard	In.	3/4	3/4	1-1/2	2	2	2	2	3
		mm	19	19	38	51	51	51	51	76
	Top-Loaded	In.	---	3/4	---	3/4	---	---	1-1/8	---
		mm	---	19	---	19	---	---	29	---
Max. Diaphragm Pressure to Stroke Actuator	Psig	40	45	45	50	45	50	45	40	
	Bar	2.8	3.1	3.1	3.4	3.1	3.4	3.1	2.8	
Max. Excess Diaphragm Pressure	Psig	70	45	45	30	15	30	15	15	
	Bar	4.8	3.1	3.1	2.1	1.0	2.1	1.0	1.0	
Max. Diaphragm Case Pressure ¹	Psig	110	90	90	65	55	65	55	55	
	Bar	7.6	6.2	6.2	4.5	3.8	4.5	3.8	3.8	
Approximate Weight	Lb	40	60	56	95	125	97	125	254	
	Kg	18	27	25	43	57	44	57	115	

1. Maximum diaphragm casing pressure must not be exceeded, and must not produce a force on the actuator stem greater than the maximum allowable actuator output thrust or the maximum allowable valve stem load.
 2. Actuator travel may be less than the value specified after being connected to the valve.

Installation

The CVS Type 667 Diaphragm Actuator is usually delivered mounted on a CVS Controls valve body. When installing the valve body into the pipeline, consult the instructions for that particular valve body.

Should you have any questions during the installation procedure, consult your CVS Controls representative.

Actuator Mounting

1. Install the stem locknuts onto the valve stem and place the travel indicator disc onto the locknuts.
2. If the valve is direct-acting, push the valve stem down to close the valve. If the valve is reverse-acting, push the valve stem down to open the valve.
3. Place the actuator onto the valve bonnet. If necessary, use a hoist or lift the actuator in order to slip the yoke locknut over the valve stem.
4. Screw the yoke locknut onto the bonnet securing the actuator to the bonnet.
5. Apply required supply pressure to actuator. If using a 6-30 signal, apply 35 psi. If using a 3-15 signal, apply 20 psi to move the actuator stem to the top of the travel.
6. Align the indicator disc with the travel side on the actuator by adjusting the locknuts.
7. Raise the valve plug until the travel disc aligns with the top of the scale (full travel).
8. Clamp the actuator and valve body stems between the two stem connector halves. Insert and tighten both stem connector cap screws.

Note: Avoid clamping the tip of either the valve stem or the actuator stem in the stem connector. Failure to completely clamp the stems may strip the threads and affect proper operation. The length of each stem clamped in the stem connector should be equal to or greater than the diameter of that stem.

9. Lift the travel indicator disc to the stem connector and thread the stem locknuts against the stem connector.
10. Realign the travel indicator scale to show the valve position.

Loading Connection

1. The loading pressure is connected to the 1/4-inch NPT connection in the side of the yoke.
2. For the CVS 667 Actuator Size 70, remove the 1/4-inch bushing in the 1/2-inch NPT female connection to increase the connection size if desired. Piping or tubing can be used, but should be kept as short as possible to avoid transmission lag in the control signal. If an accessory is attached to the actuator ensure that it has been properly secured.
3. If the valve positioner is provided as part of the original equipment, the loading pressure connection will be made at the CVS Controls manufacturing facility.
4. Check the valve stem travel by cycling the actuator several times. Ensure that the proper travel occurs when the correct pressure range is applied to the diaphragm.

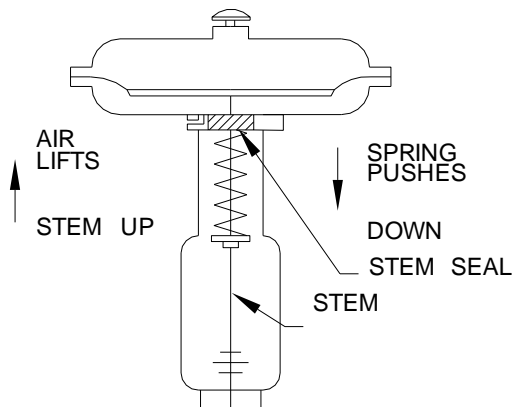

Figure 2: Schematic of CVS Type 667 Actuator

Loading Connection cont'd

5. If the valve stem travel or pressure range is incorrect, refer to the "Adjustments" section of this manual.

Do not place the valve in service if it is not responding properly to diaphragm loading pressure changes.

For ease of service, ensure that the control valve is located for easy access and serviceability with room above for accessibility. Ensure that sufficient room is provided below should removal of the actuator and valve plug be necessary.

Adjustments

Travel

Refer to the nameplate on the yoke of the actuator for details on the specific construction and operating range of the control valve assembly.

The requirements of your specific application will dictate the spring and diaphragm used in your CVS Type 667 Actuator, and when in service, the actuator should create full travel of the valve plug when diaphragm pressure is applied according to the range indicated on the name plate. Generally, the diaphragm pressure range is 3 to 15 PSI or 6 to 30 PSI, but other ranges may be used.

If the motion during the actuator travel differs from the travel stamped on the actuator nameplate, adjust according to the following directions. In order to adjust the travel of a direct-acting valve, slightly pressure the actuator to move the valve plug off of the seat. This reduces the chance of damaging the valve plug or seat during adjustments.

1. Loosen and back off the stem locknuts and indicator disc from the stem connector.
2. Loosen the stem connector cap screws.

Note: Do not use wrenches or other tools directly on the valve stem as this could cause damage to the stem surface and valve packing.

3. Tighten the locknuts (Keys 14 and 20) and complete the adjustment by either screwing the valve stem into the stem connector to lengthen travel or out of the stem connector to shorten travel.
4. Cycle the actuator to ensure that the correct travel has been achieved and repeat the adjustment if necessary.
5. When the correct travel has been reached tighten the stem connector cap screws.
6. Raise the travel indicator disc by threading the stem locknuts against the stem connector.
7. Adjust the travel scale to match the disc.

Spring

If the loading pressure range applied to reach the desired travel differs from that specified on the nameplate, a spring adjustment is required.

Check the "Bench Set" pressure range on the nameplate when the valve contains no pressure and the packing is loosely inserted in the bonnet. Refer to the "Diaphragm Pressure" range on the nameplate when the valve is controlling the specified pressure drop and the packing is tightened to stop leaks around the stem.

1. Monitor the loading pressure while making adjustments. Be sure not to exceed the pressure specifications of either the loading regulator or the actuator casings.
2. Each actuator spring has a fixed pressure span. Changing the spring compression shifts the span up or down to make the valve travel coincide with the loading pressure range.

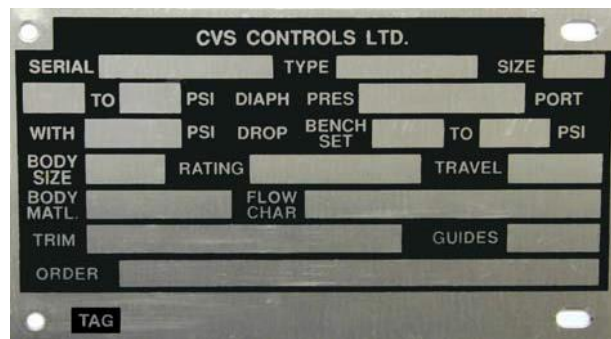

Figure 3: Nameplate on CVS Type 667 Actuator

Spring Adjustments cont'd

3. To shift the span up, turn the spring adjustor (Key 11) into the yoke. To shift the span down, turn the spring adjustor out of the yoke.

For operation of the CVS 667 Diaphragm Actuator the actuator stem and valve plug stem must move freely in response to the loading pressure change on the diaphragm.

Maintenance

Actuator parts are subject to normal wear and tear and should be inspected regularly. The frequency of inspection and replacement of parts is dependent on the severity of operating conditions.

WARNING

A sudden release of pressure or any uncontrolled process fluid can cause personal injury or damage to property. Prior to any disassembly, be sure to:

- Isolate the valve from the process,
- Release all process pressure
- Vent the actuator loading pressure, and
- Relieve all spring compression.

Disassembly

Although the following instructions describe how the CVS Type 667 Diaphragm Actuator can be completely disassembled, when inspection or repairs are required, only disassemble those parts required to accomplish the job. Key numbers refer to Figures 4 and 5.

1. Bypass the control valve and reduce the loading pressure to atmospheric.
2. Remove the tubing or piping from the connection in the top of the yoke (Key 9). For top-loaded construction also remove the piping or tubing from the connection in the upper diaphragm casing (Key 7).
3. Thread the spring adjustor (Key 2) off the stem (Key 3) to remove all spring compression.
4. If necessary remove the actuator from the valve body by separating the stem connector (Key 21) and removing the yoke locknut.
5. Remove the spring adjustor (Key 2) from the actuator stem (Key 3) and lift the spring seat and spring (Keys 4 and 1) out of the yoke.
6. Remove the diaphragm casing cap screws and nuts (Keys 10 and 14) and lift off the upper diaphragm casing (Key 7).
7. Remove the following parts: diaphragm (Key 6), diaphragm plate (Key 5), spacer (Key 32), cap screw (Key 11) and actuator stem (Key 3). Be

careful not to damage the O-rings (Key 25) when pulling the threads of the actuator stem through the seal bushing (Key 24). Remove the stem through the housing of the yoke so as not to pull the threads through the seal bushing.

8. Separate the parts of this assembly by removing the cap screw (Key 11).
9. To remove the seal bushing, remove the snap ring (Key 30) and lift out the bushing.
10. Remove the cap screws (Key 19), the lower diaphragm casing (Key 8) and the gasket (sizes 30 through 60) or O-ring (size 70) (Key 28).
11. If necessary, the down travel stops can be removed (Key 33).

Assembly

1. Place a new gasket or O-ring (Key 28) on the yoke (Key 9) and apply lubricant to the O-ring.
2. Position the lower diaphragm casing (Key 8) on the yoke, align the holes and insert and tighten the cap screws (Key 19).
3. If the down travel stops (Key 33) were removed, insert and tighten them.
4. Coat the O-rings (Keys 28 and 29) with lubricant and place them in the seal bushing (24).
5. Fill the seal bushing with lubricant, slide the bushing into the yoke (Key 9) and install the snap ring (Key 30).
6. Insert the actuator stem (Key 3) through the spring housing of the yoke, then add the lower diaphragm plate (Key 29), diaphragm (Key 6), diaphragm plate (Key 5), and the travel stop cap screw and spacer (Keys 11 and 32).
7. Place this assembly in the actuator, being careful when pushing the actuator stem through the seal bushing that the threads do not damage the O-rings.

Note: Over tightening the diaphragm cap screws and nuts can damage the diaphragm. Do not exceed 20 foot-pounds (27 Newton meters) torque.

8. Install the upper diaphragm casing (Key 7) and secure with cap screws and nuts (Keys 10 and 14). Tighten evenly using a crisscross pattern to ensure a proper seal.
9. Install the actuator spring (Key 1) and spring seat (Key 4). Apply lubricant to the threads of the actuator stem and to the surface of the spring adjustor (Key 2) that contacts the spring seat. Thread the spring adjustor onto the actuator stem.
10. Mount the actuator onto the valve, following procedures in the "Installation" section of this manual.

CVS Type 667 Actuator Parts List

The following parts list includes complete part numbers for components of the CVS Type 667 Actuator that are generally replaceable in the field, and are most commonly used. Key numbers correspond to those in Figures 4 and 5. Include the serial number of your actuator in all correspondence regarding replacement parts.

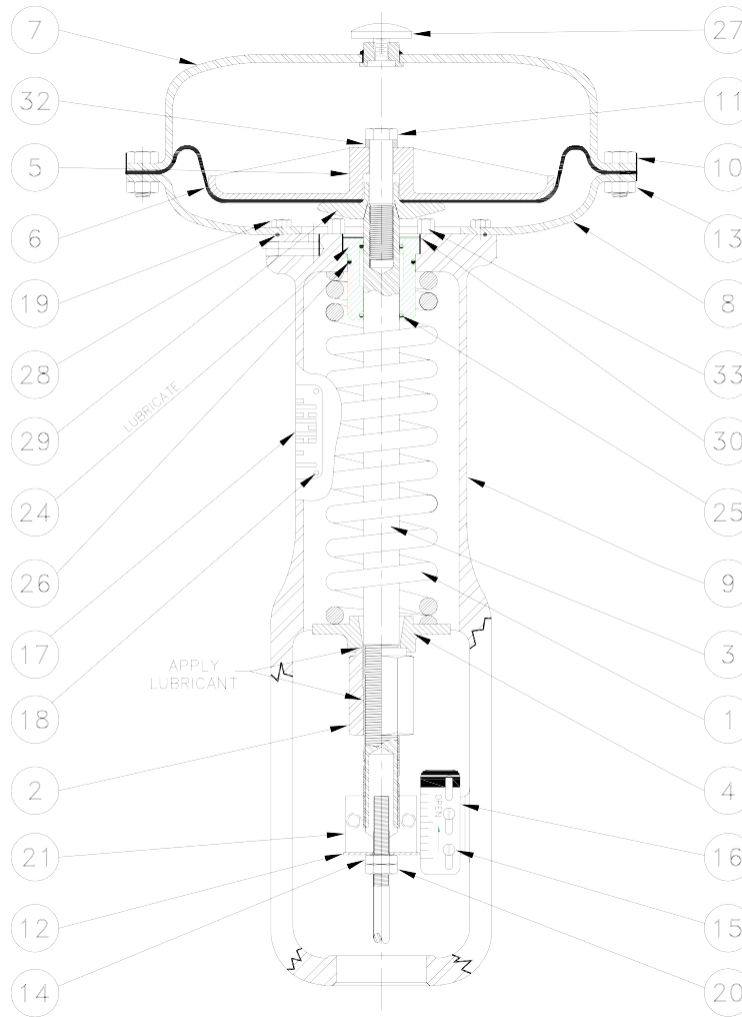

Figure 4: CVS Type 667 Actuator, Sizes 30 through 60

Table 2: Parts Reference

Key	Part Name
1	Actuator Spring
2	Spring Adjuster
3	Actuator Stem
4	Spring Seat
5	Diaphragm Plate
6*	Diaphragm
7	Upper Diaphragm Case
8	Lower Diaphragm Case
9	Yoke
10	Bolt
11	Cap Screw

Key	Part Name
12	Travel Indicator
13	Hex Nut
14	Hex Jam Nut
15	Self-Tapping Screw
16	Travel Indicator Scale
17	Nameplate
18	Drive Screw
19	Bolt
20	Hex Nut
21	Stem Connector
22	Twin Speed Nut (not shown)

Key	Part Name
23	Pipe Bushing (Size 70 only) (not shown)
24	Seal Bushing
25	O-Ring
26	O-Ring
27	Vent assembly
28	Gasket / O-Ring
29	Lower Diaphragm Plate
30	Snap Ring
31	Washer
32	Spacer
33	Down Stop

* Recommended spare part

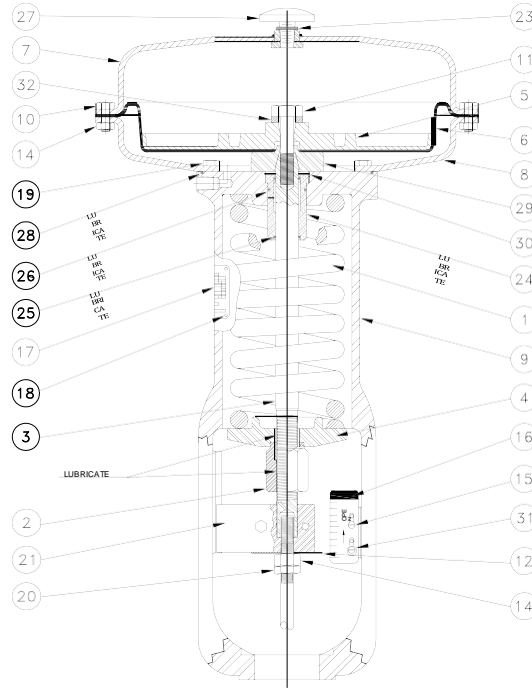

Figure 5: CVS Type 667 Actuator, Size 70

Table 3: Parts List

Key	Description	Part Number		
1	Actuator Spring	Consult CVS Controls		
2	Spring Adjustor Steel Zinc Pl	Size 30	CVS1E801724102	
		Sizes 34, 40	CVS1E821024102	
		Sizes 45, 46, 50, 60	CVS1E846224102	
		Size 70	CVS1N131824102	
3	Actuator Stem SST	Size 30	CVS1E801624222	
		Size 34	CVS1E884724222	
		Size 40	CVS1E820924222	
		Sizes 45, 46	CVS1J332824222	
		Sizes 50, 60	CVS1E846124222	
		Size 70	CVS2N131724222	
4	Spring Seat Steel Zinc Pl	Size 30, Steel	CVS1U425623122	
		Sizes 34,40, Steel	CVS1R179923122	
		Sizes 45, 46, 50, 60, Steel	CVS1R180023122	
		Size 70	Cast Iron	CVS1N129619052
			Steel	CVS1N757722012
5	Diaphragm Plate	Size 30, Aluminum	CVS30A2880X012	
		Sizes 34,40, Cast Iron	CVS3E880519042	
		Sizes 45, 50, Aluminum	CVS30A2882X012	
		Sizes 46, 60, Cast Iron	CVS2E847519042	
		Size 70, Cast Iron	CVS2N127019042	
6	Diaphragm Nitrile	Size 30	CVS2E800002202	
		Sizes 34, 40	CVS2E669902202	
		Sizes 45, 50	CVS2E859602202	
		Sizes 46, 50	CVS2E859802202	
		Size 70	CVS2N130902202	
7	Upper Diaphragm Casing Steel	Size 30	CVS2E800728992	
		Sizes 34, 40	CVS2E681428992	
		Sizes 45, 50	CVS3E844628992	
		Sizes 46, 60	CVS3E846728992	
		Size 70	CVS2N127828992	

Table 3: Parts List

Key	Description	Part Number	
8	Lower Diaphragm Casing Steel	Size 30	CVS2E801125062
		Sizes 34, 40	CVS2E682625062
		Sizes 45, 50	CVS3E845325062
		Sizes 46, 60	CVS3E847725062
		Size 70	CVS2N131025062
9	Yoke Cast Iron	Size 30	CVS3E801419042
		Size 34	CVS2E884619042
		Size 40	CVS3E820819042
		Sizes 45, 46	CVS3E900819042
		Sizes 50, 60	CVS3E845919042
		Size 70	CVS3N130319042
10	Cap Screw Steel, Zinc PL	Size 30 (12 req'd)	CVS1E760324052
		Sizes 34, 40 (16 req'd)	CVS1E760324052
		Sizes 45, 50 (20 req'd)	CVS1A675124052
		Size 46, 60 (24 req'd)	CVS1A675124052
		Size 70 (28 req'd)	CVS1A582824052
11	Cap Screw Steel	See Following Table	
12	Travel Indicator, SST	Sizes 30, 34	CVS1E793138992
		Sizes 40, 45, 46	CVS1E807538992
		Sizes 50, 60	CVS1E832838992
		Size 70	CVS1B971838992
13	Hex Nut, SST (Refer to Key 10 for quantities)	CVS1A346524122	
14	Hex Jam Nut, Steel Zinc PL	Sizes 30, 34 (2 req'd)	CVS1P131224142
		Size 40 (1 req'd)	CVS1A413224122
		Size 45 (None req'd)	---
		Size 46 (1 req'd)	CVA1A413224122
		Sizes 50, 60, 70 (1 req'd)	CVS1A375424122
15	Self-tapping Screw, SST	Sizes 30, 34, 40, 45, 46 (2 req'd)	CVS1E793238992
		Sizes 50, 60, 70 (2 req'd)	CVS1E831338992
16	Travel Indicator Scale, SST	See Following Table	
17	Nameplate, SST	CVS1K325738992	
18	Drive Screw, SST (4 req'd)	CVS1A368228982	
19	Cap Screw Steel Zinc PL	Size 30 (6 req'd)	CVS1D529824052
		Sizes 34, 40 (6 req'd)	CVS1A368424052
		Sizes 45, 46, 50, 60 (8 req'd)	CVS1A368424052
		Size 70 (12 req'd)	CVS1N129328992
20	Hex Nut Steel Zinc PL	Sizes 30, 34 (None req'd)	---
		Size 40 (1 req'd)	CVS1A353724122
		Size 45 (2 req'd)	CVS1A353724122
		Size 46 (1 req'd)	CVS1A353724122
		Sizes 50, 60, 70 (1 req'd)	CVS1A351124122
21	Stem Connector Steel Zinc PI	Sizes 30, 34	CVS1E7977000A2
		Size 40	CVS1E8033000A2
		Sizes 45, 46	CVS1J333000A2
		Sizes 50, 60	CVS1E8337000A2
		Size 70	CVS1N1319000A2
22	Twin Speed Nut, SST	Sizes 30, 34	CVS1E793938992
		Sizes 40, 45, 46	CVS1E808438992
		Sizes 50, 60, 70	CVS1E833538992
23	Pipe Bushing, Steel Zinc PL	Size 70 CVS1C379026232	
24	Seal Bushing, Brass	Size 30	CVS1E791214012
		Sizes 34, 40	CVS1E682814012
		Sizes 45 to 60	CVS1E845714012
		Size 70	CVS1N131614012
25	O-Ring, Nitrile (2 req'd)	Size 30	CVS1E591406992
		Sizes 34, 40	CVS1D237506992
		Sizes 45 to 60	CVS1C562206992
		Size 70	CVS1E736906992
26	O-Ring, Nitrile	Sizes 30, 34, 40	CVS1C415706992
		Sizes 45, 46, 50, 60, 70	CVS1E845806992
27	Vent Assembly	CVSY602X1A11	
28	Gasket, Garlock	Sizes 30, 34, 40	CVS1E801204022
		Sizes 45, 46, 50, 60	CVS1E845404022
	O-Ring, Nitrile	Size 70	CVS1D269106992

Table 3: Parts List

Key	Description	Part Number	
29	Lower Diaphragm Plate	Size 30, Aluminum	CVS1E791344022
		Sizes 34, 40, Aluminum	CVS1E682744022
		Sizes 45, 46, 50, 60, Aluminum	CVS1E845544022
		Size 70, Steel	CVS1N131524092
30	Snap Ring, SST	Sizes 30, 34, 40	CVS1E801337022
		Sizes 45 to 70	CVS1E845638992
31	Washer (2 req'd)	Size 70, Steel	CVS1E873028992
32	Spacer, Steel Zinc Pl		See Following Table
33	Down Stop, Steel	Sizes 30 to 40	CVS1H493524092
		Sizes 45 to 60	CVS1H494324092

Key 11 Cap Screw, Steel
Key 32 Spacer, Steel

Actuator Size	Key	Travel In (mm)			
		7/16 (11)	5/8 (16)	3/4 (19)	1-1/8 (29)
30	11	CVS1A685724052	CVS1A685724052	CVS1B227524052	---
	32	CVS1R408724092	CVS1R408624092	CVS1R408524092	---
34	11	CVS1R408828992	CVS1R408928992	CVS1R408928992	---
	32	CVS1R409324092	CVS1R409424092	CVS1R409524092	---
40	11	CVS1R408828992	CVS1R408828992	CVS1R408928992	CVS1R409128992
	32	CVS1R409324092	CVS1R409424092	CVS1R409524092	CVS1R409624092
45, 46, 50, 60	11	CVS1R409824052	CVS1R409824052	CVS1R409824052	CVS1R409924052
	32	CVS1R410324092	CVS1R410424092	CVS1R410524092	CVS1R410824092
70	11	---	---	CVS1R411024052	CVS1R411524092
	32	---	---	CVS1R411624092	CVS1R411124052

Actuator Size	Key	Travel In (mm)		
		1-1/2(38)	2 (51)	3 (76)
30	11	---	---	---
	32	---	---	---
34	11	---	---	---
	32	---	---	---
40	11	CVS1R409228992	---	---
	32	CVS1R409724092	---	---
45, 46, 50, 60	11	CVS1R410124052	CVS1R410224052	---
	32	CVS1R410624092	CVS1R410724092	---
70	11	CVS1R409824052	CVS1R409924092	CVS1R410224052
	32	CVS1R411424092	CVS1R411324052	CVS1R410724092

Key 16 Travel Indicator Scale

Actuator Size	Travel In (mm)			
	7/16 (11)	5/8 (16)	3/4 (19)	1-1/8 (29)
30	CVS1E793438992	CVS1E793538992	CVS1E793638992	---
34	CVS1E793438992	CVS1E793538992	CVS1E793638992	---
40, 45, 46	CVS1E807638992	CVS1E807738992	CVS1E808138992	CVS1E808238992
50	CVS1E833038982	CVS1E833038992	CVS1E833138992	CVS1E833238992
60	CVS1F535238982	CVS1E833038992	CVS1E833138992	CVS1E833238992
70	---	---	CVS1H745738992	CVS1H745838992

Actuator Size	Travel In (mm)		
	1-1/2(38)	2 (51)	3 (76)
30	---	---	---
34	---	---	---
40, 45, 46	CVS1E803838992	CVS1R444538982	---
50	CVS1E833338992	CVS1E833438992	---
60	CVS1E833338992	CVS1E833438992	---
70	CVS1H745938992	CVS1H746038992	CVS1H746138992