

# VRG Controls, LLC

## VMO Valve Manual Override

### Instruction Manual

**Applicable Models:**

This Instruction Manual applies to the following VRG – Valve Manual Override Models. To confirm suitability for additional models and/or components, please contact VRG Controls or view us online at [www.vrgcontrols.com](http://www.vrgcontrols.com).

**VMO-150****VMO-250****Stay in Touch!**

Scan the QR Code at right  
for company information  
and product updates

**Our Address:**

VRG Controls, LLC  
Highland Park, Illinois USA  
[www.vrgcontrols.com](http://www.vrgcontrols.com)  
eMail: [Sales@VRGControls.com](mailto:Sales@VRGControls.com)

---

**VPC Instruction Manual Table of Contents**

---

<b>Section</b>	<b>Description</b>	<b>Page</b>
<b>1</b>	<b>Scope of Manual</b>	<b>3</b>
<b>2</b>	<b>Technical Assistance</b>	<b>3</b>
<b>3</b>	<b>Applicable Models</b>	<b>3</b>
<b>4</b>	<b>Description</b>	<b>3</b>
<b>5</b>	<b>VMO Valve Manual Override Technical Specifications</b>	<b>4</b>
<b>6</b>	<b>Component and Port Identification</b>	<b>5</b>
<b>7</b>	<b>Dimensional Drawings</b>	<b>5</b>
<b>8</b>	<b>VMO Operation Instructions</b>	<b>6</b>
<b>9</b>	<b>VMO Application Schematics</b>	<b>7</b>

**Scope of Manual:**

This Instruction Manual provides instructions for installation and operation of VRG Controls VMO Valve Manual Overrides. This product is typically utilized in conjunction with control valves, pneumatic actuators and a variety of other ancillary devices and accessories. For information on products other than those manufactured by VRG Controls, please consult the appropriate manufacturer.

**Warning:**

VMO Valve Manual Overrides utilize high pressure flammable natural gas or other pneumatic supply as part of their standard operation. Improper installation, operation, maintenance and adjustment of these devices can result in property damage, personal injury or death. Only those qualified through training should install, operate, maintain or adjust this product. The VMO Valve Manual Override IS NOT A FIELD SERVICABLE DEVICE AND SHOULD NOT BE DISASSEMBLED. Contact your local VRG Controls sales representative or VRG Controls direct for additional information or assistance.

**Technical Assistance:**

For technical assistance with VRG products, please contact your local VRG Controls sales representative or VRG Controls direct. In order to facilitate technical assistance, we strongly recommend that obtain the MODEL NUMBER and SERIAL NUMBER where applicable of the product for which you require assistance prior to contact us.

**Stay in Touch!**

Scan the QR Code at right  
for company information  
and product updates

**Our Address:**

VRG Controls, LLC  
467 Ridge Road  
Highland Park, Illinois USA  
[www.vrgcontrols.com](http://www.vrgcontrols.com)  
eMail: [Sales@VRGControls.com](mailto:Sales@VRGControls.com)

We recommend that you record the MODEL NUMBER and SERIAL NUMBER where applicable of all VRG Products installed at each application location in the table below for future reference.

**Applicable Models:**

This Instruction Manual applies to the following VRG – Valve Manual Override Models. To confirm suitability for additional models and/or components, please contact VRG Controls or view us online at [www.vrgcontrols.com](http://www.vrgcontrols.com)

**VMO-150****VMO-250****Description:**

The VMO Valve Manual Override is the ideal device to provide manual operation of pneumatically actuated ON-OFF Type Remote Control Valves (RCV's) and Regulating Control Valves. The VMO allows the operator to override the primary control instrumentation and position the actuated valve in open, closed or any intermediate positions. VMO Series Valve Manual Overrides are the perfect device for valve maintenance, commissioning or emergency operation. All units are provided with standard locking provision to prevent unauthorized operation and facilitate lockout / tagout procedures.

**Applications:**

The VMO Valve Manual Override is designed to provide manual operation of pneumatically actuated ON-OFF Type Remote Control Valves (RCV's) and Regulating Control Valves. The VMO may be installed in conjunction with a number of different PNEUMATIC ACTUATOR and CONTROL INSTRUMENTATION configurations. A list of typical compatible actuator and instrumentation may be found below. We recommend that you contact your local VRG Controls sales representative or VRG Controls direct for application assistance.

**Compatible Actuator Types**

- Compatible Actuator Types
- Double Acting Piston
- Spring Return Piston
- Scotch Yoke Style
- Crank Arm Style
- Spring & Diaphragm Rotary
- Spring & Diaphragm Linear
- Rotary Vain
- Rack & Pinion

**Compatible Instrumentation**

- Pneumatic Valve Positioners
- Electro-Pneumatic Positioners
- Valve Pilot Controllers
- Digital Valve Controllers
- Solenoid Valves
- Pilot-Operated Valves
- VPC Valve Pilot Controllers

**VMO Valve Manual Override Technical Specifications**

Available Models		
VMO Model	P <sub>Supply</sub> Max.	P <sub>Differential</sub> Max.
VMO-150	400 psig	150 psid
VMO-250	400 psig	250 psid

*Where: P<sub>Differential</sub> = P<sub>Supply</sub> - P<sub>Discharge</sub>*

Specifications	
<b>Type</b>	Rotary, lapped disc, 5-position/6-way manually operated valve with manifolded porting assembly
<b>Ports</b>	¼ in. FNPT (6) Manifolded to Body
<b>Flow Capacity</b>	C <sub>v</sub> = 0.40
<b>Weight</b>	8.0 Lbs. (3.6 kg)
<b>Mounting</b>	Back Face Mount
<b>Dimensions</b>	See Figure Above
<b>Action</b>	Double Acting or Single Acting in same device
<b>Options</b>	Limit Switches to indicate AUTO or MANUAL operation

Materials	
<b>Coating</b>	Red Polyurethane Topcoat & Zinc Primer over Chemical Cleaning
<b>Body</b>	Carbon Steel
<b>Bolting</b>	316 Stainless Steel SHCS
<b>Body O-Rings</b>	Buna-N
<b>Handle (Knob)</b>	Impact Resistant Black Phenolic
<b>Handle (Shaft)</b>	304 Stainless Steel
<b>Internal Discs</b>	Precision Lapped Carbon Steel
<b>Manifolds</b>	304 Stainless Steel
<b>Mounting Plate</b>	304 Stainless Steel

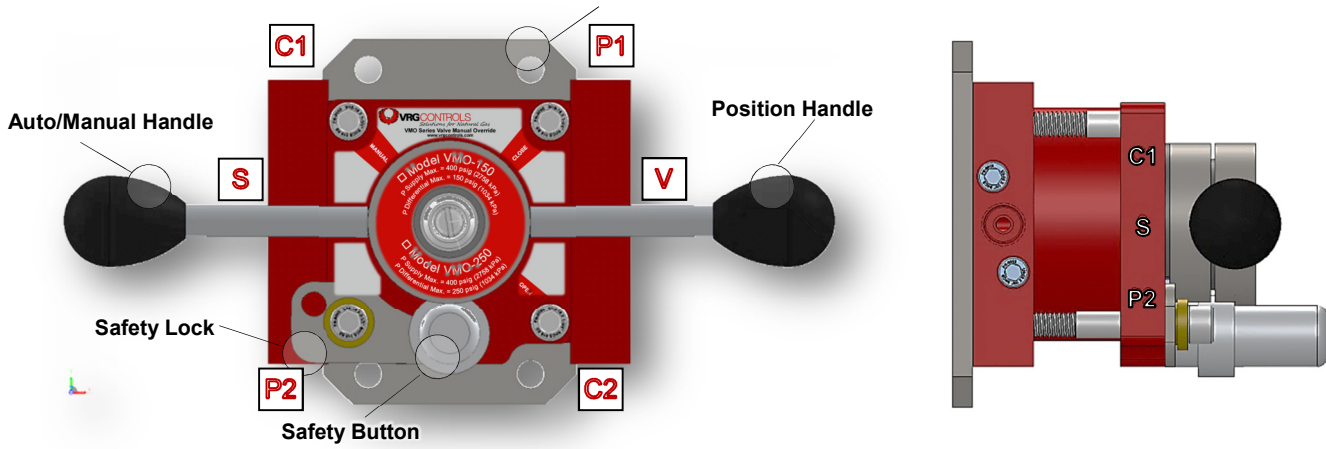
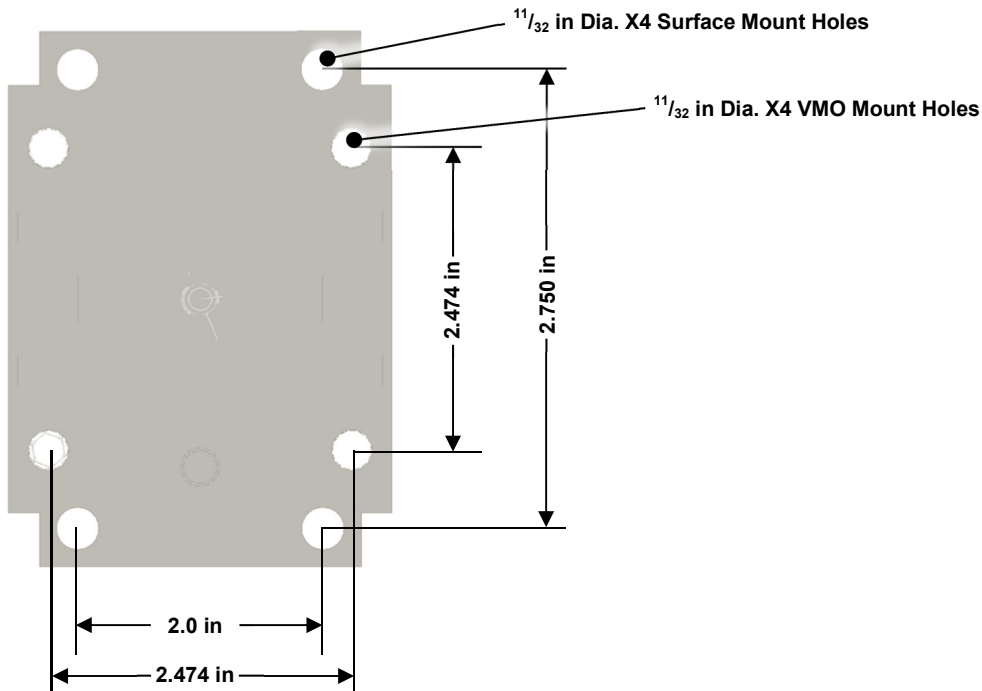
**Component and Port Identification:**
**VMO Mounting Backplate**

**VMO Backplate Dimensions (1/4 in Thick):**

**VMO Operation Instructions**

**How to CLOSE Valve Using VMO Valve Manual Override**

**STEP 1 – START AT AUTO MODE**

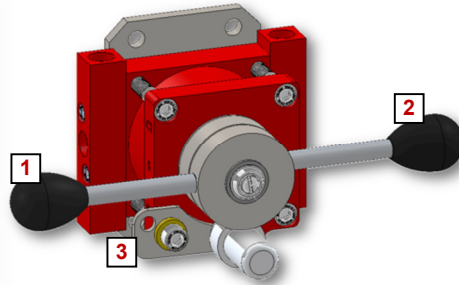
1. Valve is in AUTOMATIC MODE with AUTO/MANUAL HANDLE at AUTO (A) Position.
2. POSITION HANDLE is at NEUTRAL (N) Position.
3. SAFETY LOCK is engaged.



**STEP 2- ENGAGE MANUAL MODE**

1. Remove padlock from SAFETY LOCK if applicable.
2. Rotate SAFETY LOCK to disengage
3. Depress SAFETY BUTTON
4. Rotate AUTO/MANUAL HANDLE up to MANUAL (M) Position.
5. Ensure that SAFETY BUTTON releases once AUTO/MANUAL handle is at MANUAL (M) mode to allow movement of POSITIONING HANDLE.

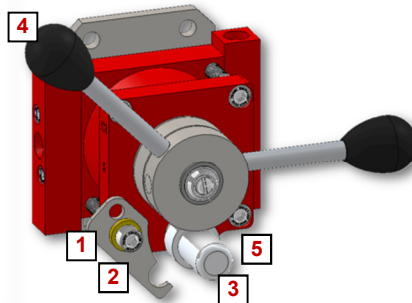

**STEP 3- MOVE TO CLOSE**

1. Rotate POSITION HANDLE up to CLOSE (C) position valve to desired position.
2. To move valve to FULL CLOSED Position, leave POSITION HANDLE at CLOSE (C) position.
3. POSITION HANDLE LOCK may be engaged for "lock out/tag out" procedure. Optional POSITION HANDLE LOCK not shown.

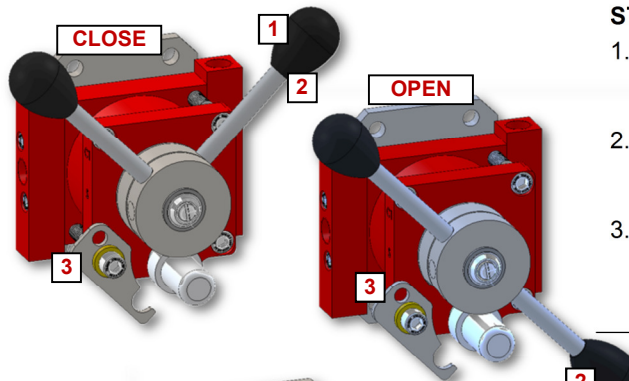

**STEP 4- STOP AT INTERMEDIATE POSITION**

1. Valve may be stopped in intermediate position by returning POSITIONING HANDLE to NEUTRAL (N) position.

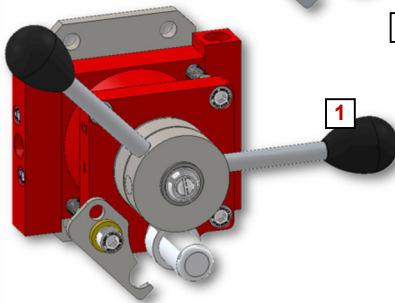

**STEP 5- RETURN TO AUTO MODE**

1. Move POSITIONING HANDLE to NEUTRAL (N) Position
2. Depress SAFETY BUTTON
3. Rotate AUTO/MANUAL HANDLE to AUTO (A) Position.
4. Ensure that SAFETY BUTTON releases once AUTO/MANUAL handle is at AUTO (A) mode
5. Engage SAFETY LOCK if applicable

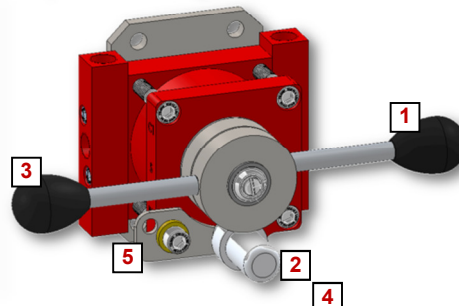

**How to OPEN Valve Using VMO Valve Manual Override**

**STEP 1 – START AT AUTO MODE**

1. Valve is in AUTOMATIC MODE with AUTO/MANUAL HANDLE at AUTO (A) Position.
2. POSITION HANDLE is at NEUTRAL (N) Position.
3. SAFETY LOCK is engaged.

**STEP 2- ENGAGE MANUAL MODE**

1. Remove padlock from SAFETY LOCK if applicable.
2. Rotate SAFETY LOCK to disengage
3. Depress SAFETY BUTTON
4. Rotate AUTO/MANUAL HANDLE up to MANUAL (M) Position.
5. Ensure that SAFETY BUTTON releases once AUTO/MANUAL handle is at MANUAL (M) mode to allow movement of POSITIONING HANDLE.

**STEP 3- MOVE TO OPEN**

1. Rotate POSITION HANDLE up to OPEN (O) position valve to desired position.
2. To move valve to FULL OPEN Position, leave POSITION HANDLE at OPEN (O) position.
3. POSITION HANDLE LOCK may be engaged for "lock out/tag out" procedure. Optional POSITION HANDLE LOCK not shown.

**STEP 4- STOP AT INTERMEDIATE POSITION**

1. Valve may be stopped in intermediate position by returning POSITIONING HANDLE to NEUTRAL (N) position.

**STEP 5- RETURN TO AUTO MODE**

1. Move POSITIONING HANDLE to NEUTRAL (N) Position
2. Depress SAFETY BUTTON
3. Rotate AUTO/MANUAL HANDLE to AUTO (A) Position.
4. Ensure that SAFETY BUTTON releases once AUTO/MANUAL handle is at AUTO (A) mode
5. Engage SAFETY LOCK if applicable

VMO Valve Manual Override Installation Schematics

No.	VMO	Actuator Mode	Actuator Failure Mode	Page
1	VMO-150 or VMO-250	Double Acting	Double Acting	7

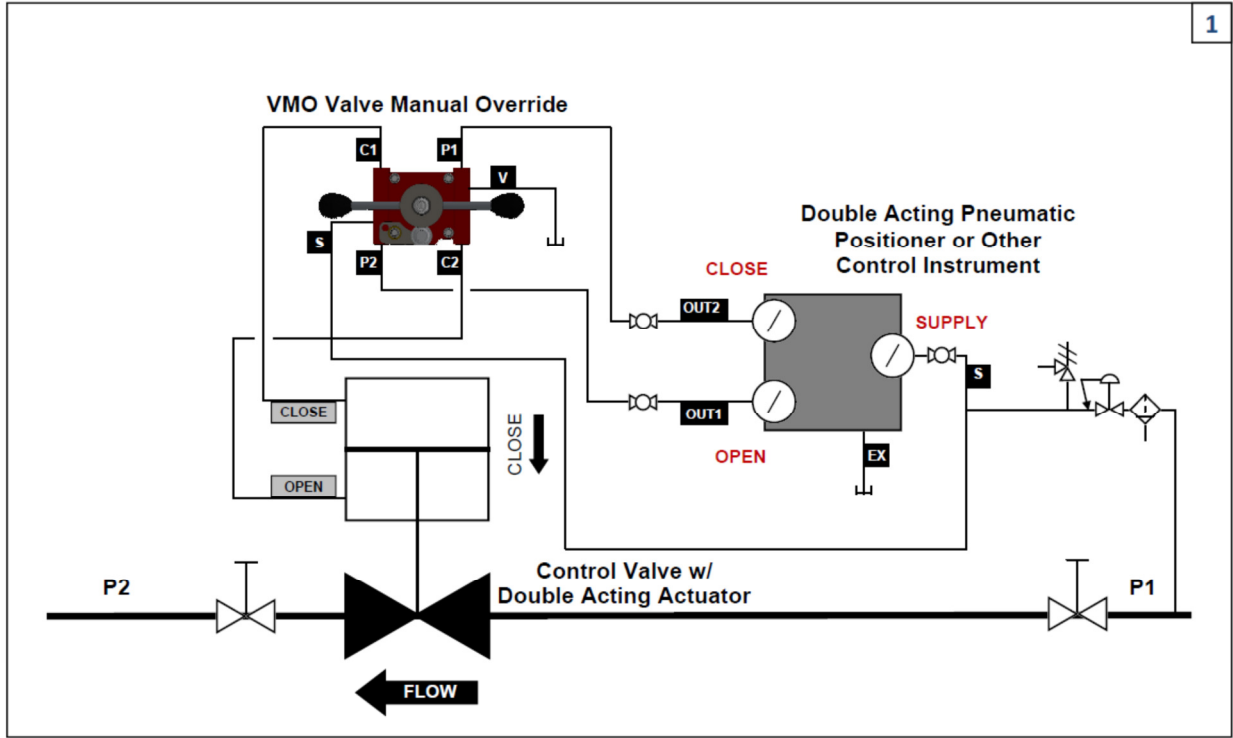

No.	VMO	Actuator Mode	Actuator Failure Mode	Page
2	VMO-150 or VMO-250	Single Acting Spring Return	Spring Open	7

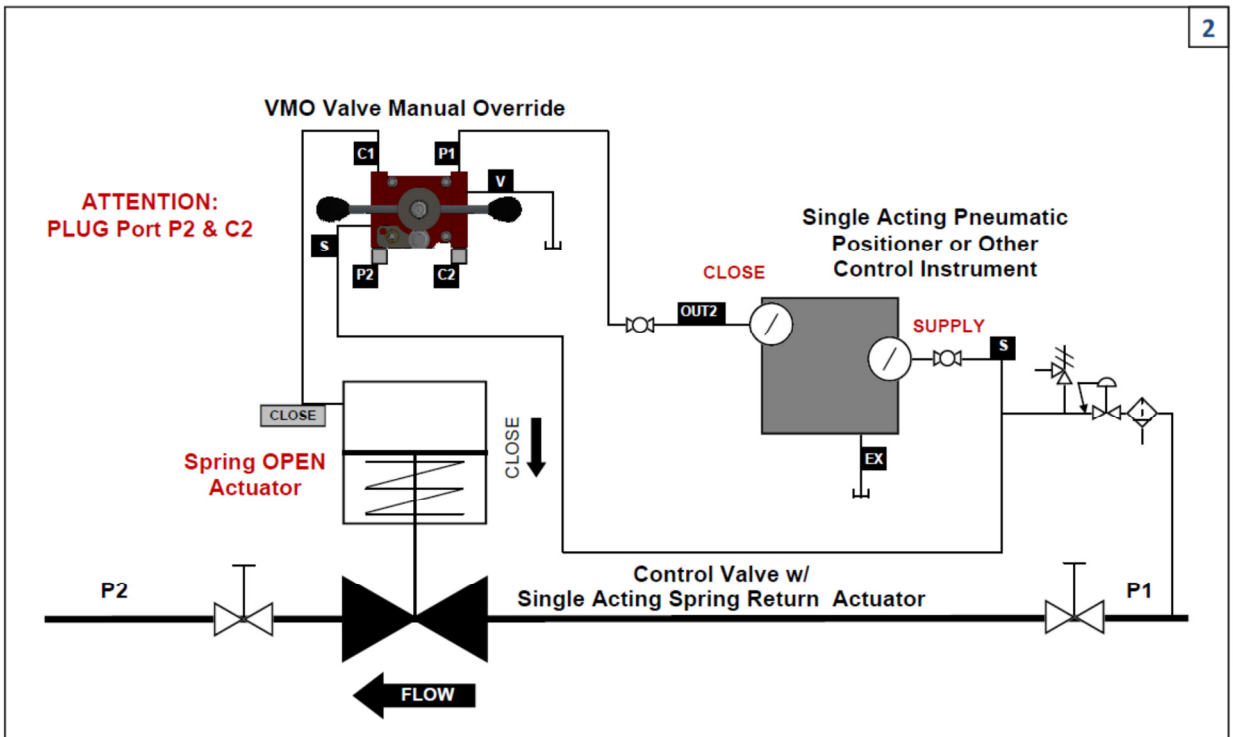

VMO Valve Manual Override Installation Schematics (Cont'd.)

No.	VMO	Actuator Mode	Actuator Failure Mode	Page
3	VMO-150 or VMO-250	Single Acting Spring Return	Spring Close	8

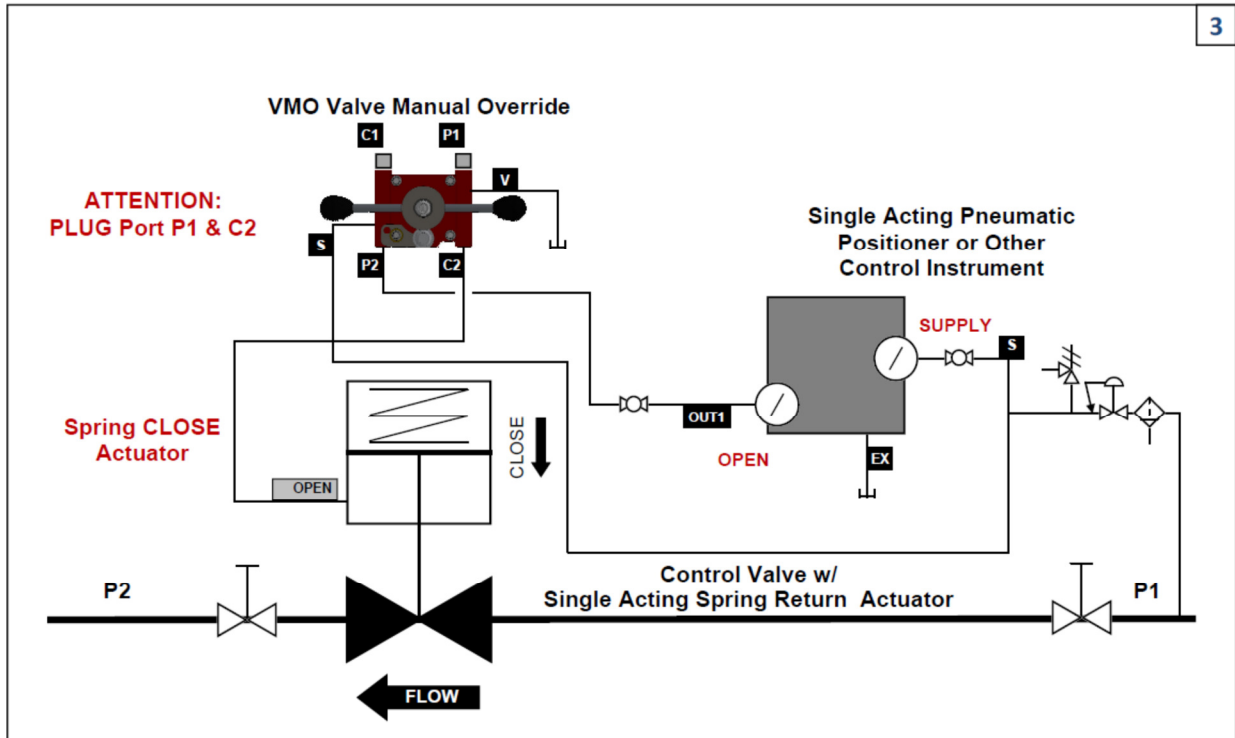

**Stay in Touch!**  
Scan the QR Code at right  
for company information  
and product updates



**Our Address:**  
VRG Controls, LLC  
Highland Park, Illinois USA  
www.vrgcontrols.com  
eMail: [Sales@VRGControls.com](mailto:Sales@VRGControls.com)