

VPC "BV" SERIES VALVE PILOT CONTROLLER INSTRUCTION MANUAL



VRG Controls, LLC
Lake Zurich, IL 60047 USA

email: sales@vrgcontrols.com
www.vrgcontrols.com

VPC-1500 MAOP Sensing 1500 psig (10342 kPa)
VPC-700 MAOP Sensing 700 psig (4826 kPa)
VPC-225 MAOP Sensing 225 psig (1551 kPa)
All Other Ports MAOP 150 psig (1034 kPa)
Temperature -20 to +160 °F (-29 to +71 °C)

  0496





PATENT NO.:
US 9,400,060 B2
US 10,234,047 B2

Applicable Models:

This Instruction Manual applies to the following VRG - Valve Pilot Controllers. To confirm suitability for additional models and/or components, please contact VRG Controls or view us online at www.vrgcontrols.com.

VPC-225-SA-BV
VPC-700-SA-BV
VPC-1500-SA-BV
VPC-225-SA-BV-ID
VPC-700-SA-BV-ID
VPC-1500-SA-BV-ID

VPC-225-SA-BV-GAP
VPC-700-SA-BV-GAP
VPC-1500-SA-BV-GAP
VPC-225-DA-BV
VPC-700-DA-BV
VPC-1500-DA-BV

STAY IN TOUCH!

Scan the QR Code at right for company information and product updates.



ADDRESS: VRG Controls, LLC.
1199-B Flex Court
Lake Zurich, IL 60047, USA
TOLL FREE: (800) 844-FLOW-VRG
FAX: (208) 246-0304
E-MAIL: sales@vrgcontrols.com
WEBSITE: vrgcontrols.com

DESCRIPTION	PAGE
Scope of Manual	3
Technical Assistance	3
Applicable Models	4
Descriptions	4
VPC-BV Valve Pilot Controller Technical Specifications	5
Model Number Explanation	6
VPC Controller Spring Ranges and Performance Specifications	7
Flow Calculations	8
How It Works Descriptions	9
VPC-BV Initial Adjustment Single Acting Table	10
VPC-BV Initial Adjustment Double Acting Table	11
Application Based Fine Tuning Setting Guidelines	12-13
VPC-BV Assembly Configuration Summary	14
VPC-BV Assembly Configurations	15-18
VPC-BV Repair Kit	19
Factory Quality Checklist	20
VPC-BV Application Schematics Table of Contents	21
VPC-BV Series Valve Application Diagrams	22-52
Annual Maintenance Checklist	53

SCOPE OF MANUAL

This Instruction Manual provides instructions for installation, maintenance, adjustment and troubleshooting of VRG Controls VPC - Valve Pilot Controllers. This product is typically utilized in conjunction with control valves, pneumatic actuators and a variety of other auxiliary devices and accessories. For information on products other than those manufactured by VRG Controls, please consult the appropriate manufacturer. Note that many of the necessary instruction manuals for VRG and non-VRG manufactured components are available via the VRG website at: www.vrgcontrols.com.

WARNING

VPC - Valve Pilot Controllers utilize high pressure flammable natural gas or other pneumatic supply as part of their standard operation. Improper installation, operation, maintenance and adjustment of these devices can result in property damage, personal injury or death. Only those qualified through training should install, operate, maintain or adjust this product. Contact your local VRG Controls sales representative or VRG Controls direct for additional information or assistance.

TECHNICAL ASSISTANCE

For technical assistance with VRG products, please contact your local VRG Controls sales representative or VRG Controls direct. In order to facilitate technical assistance, we strongly recommend that obtain the MODEL NUMBER and SERIAL NUMBER of the product for which you require assistance prior to contact us. MODEL NUMBER and SERIAL NUMBER may be found on the PRODUCT ID LABEL located on the front of the VPC product on the center face of lower portion of the power assembly.

We recommend that you record the MODEL NUMBER and SERIAL NUMBER of all VRG Products installed at each application location in the table below for future reference.

Product ID Label



INSTALLED ITEM IDENTIFICATION LOG

ITEM	TAG	MODEL NUMBER	SERIAL NUMBER
1			
2			
3			
4			
5			
6			
7			
8			
Example	Run 1 Monitor Regulator	VPC-700-DA-BV	0912123V

Applicable Models:

This Instruction Manual applies to the following VRG - Valve Pilot Controllers. To confirm suitability for additional models and/or components, please contact VRG Controls or view us online at www.vrgcontrols.com.

VPC-225-SA-BV
VPC-700-SA-BV
VPC-1500-SA-BV
VPC-225-SA-BV-ID
VPC-700-SA-BV-ID
VPC-1500-SA-BV-ID

VPC-225-SA-BV-GAP
VPC-700-SA-BV-GAP
VPC-1500-SA-BV-GAP
VPC-225-DA-BV
VPC-700-DA-BV
VPC-1500-DA-BV

DESCRIPTION

The VPC Valve Pilot Controller represents a breakthrough in Valve Control technology. The VPC provides a modular, plug & play pressure control system for use in conjunction with pneumatically actuated control valves. The VPC features a simplified 5-in-1 configuration that provides compatibility with double acting and single acting (spring return) control valves utilizing a single platform. The VPC may be easily reconfigured in the field to provide compatibility with almost any pneumatic control valve on the market. The highly accurate performance and ZERO emissions capabilities of the VPC provide the desired features to meet natural gas industry needs. The VPC was designed by the inventor of the original "Valve Regulator Pilot" and features patented technological advances that provide reliability, convenience, and performance above and beyond previous technologies. VPC - Valve Pilot Controllers represent the future of control valve pressure control technology and are backed up by the industries' most experienced team.

DEFINITIONS**WARNING:**

If not observed, user incurs a high risk of severe damage to actuator and/or fatal injury to personnel.

CAUTION:

If not observed, user may incur damage to actuator and/or injury to personnel.

NOTE:

Advisory and information comments provided to assist maintenance personnel to carry out maintenance procedures.

APPLICATIONS

The VPC Controller is designed to provide self-contained pressure control when incorporated with pneumatic control valves. The system utilizes pressurized natural gas or from the pipeline to operate and can address a number of common pipeline pressure control applications. Contact VRG Controls for assistance with your application.

- Primary Pressure Control (Active)
- Overpressure Protection (Monitor)
- Underpressure Protection (Standby)
- Backpressure Control
- Tandem Pressure Control
- Two-Stage Pressure Control
- Split Range Pressure Control
- Power Plant Fuel Gas Feed
- Compressor Suction Control
- ON-OFF High-Low set point

TABLE 1.0 VPC VALVE PILOT CONTROLLER TECHNICAL SPECIFICATIONS



PATENT NO.:
US 9,400,060 B2

VPC Model	VPC-SA-BV	VPC-SA-BV-ID	VPC-SA-BV-GAP	VPC-DA-BV	VPC-DA-SN
Type	Variable	Variable	Discrete (On-Off)	Variable	Variable
Outputs	Single Acting (1)			Double Acting (2)	
Internal Valve Logic	NC Balanced Valve ¹				NO Seat & Nozzle ¹
Setpoint Range	3-1500 PSIG (22-10,342 kPa)				
Temperature Range	-20°F to +160°F (-29°C to +71°C)				
Consumption					
Steady State Control	ZERO ²			<10 scfh ³	≈100 scfh ³
Full Open	ZERO			ZERO ⁴	
Full Closed	ZERO			ZERO ⁴	
ZERO Emissions	ZERO Atmospheric Emissions May Be Achieved When "Vent to Pressure System" Feature Utilized				
EPA Specifications	Exceeds EPA Ruling, EPA-HQ-OAR-2010-0505, requiring <6 SCFH bleed rate by October 2013.				
Pneumatic					
Supply Gas Quality	Dry, Filtered @ 10µ Natural Gas or Air				
Max Supply Gas Pressure	400 psig (2758 kPa)				
Min Supply Gas Pressure	20 psig				
Max Discharge ΔP	150 psig (1034 kPa)				
Min Discharge ΔP	20 psig (138 kPa)				
Connections	All Ports ¼ FNPT				
Construction					
External Parts	VRG Military Grade Aluminum Alloy with "Stealth System" Corrosion Protection				
Internal Parts	316SS – Optional Construction				
Diaphragms	316 SS				
O-Rings	Buna-N, Viton Optional				
Control Springs	Buna-N, Viton Optional				
Gauges	Painted Alloy Steel				
Weight	2.5 in. Liquid-Filled SS Case & Body				
Approx. Dimensions	20 lbs. (9.0 kg)				
Compatible Actuators & Control Valves					
SA Spring & Diaphragm Act.	■	■	■		
SA Spring & Piston Act.	■	■	■		
Double Acting Piston Act.	■ ⁵	■ ⁵	■ ⁵	■	■
"Jet" Regulator	■	■	■		
Pneumatic Positioner		■			
Volume Booster	■	■			■

NOTES

1. NC Balanced Valves and NO Seat & Nozzle internal components may be exchange/converted to meet application requirements
2. ZERO Steady State emissions achieved when VPC properly adjusted to exhibit factory advised deadband setting
3. Consumption is approximate and based upon 100 psig Supply Gas number 3 orifice, 98% output. Atmosphere

- emissions may be completely eliminated when Discharge to Pressure System incorporated.
4. Double acting VPC's require addition of No-Vent Device to achieve ZERO emissions at full open and full closed
5. Double Acting Piston Actuators Equipped with Single Acting VPC requires additional interface instrumentation such as pneumatic positioner or pilot-operated trigger valve (GAP).

TABLE 2.0 MODEL NUMBER EXPLANATION

Base Model		Pressure Series		Output Type		Internal Valve Logic		Additional	
VPC	Valve Pilot Controller	225	225 psig Max Sensing	DA	Double Acting	BV	Balanced Valve	ID	I-D Control
		700	700 psig Max Sensing	SA	Single Acting	SN	Seat & Nozzle	GAP	Gap Control
		1500	1500 psig Max Sensing						

Example: Model VPC-700-SA-BV-ID

Valve Pilot Controller, 700 psig Max Sensing, Single Acting Output, Balanced Valve Internals, with I-D Control Function

VPC MODEL NUMBER IDENTIFICATION LABEL



VRG CONTROLS
Solutions for Natural Gas

225 Pressure Series —VPC Model Number

- VPC-225-SA-BV
- VPC-225-SA-BV-ID
- VPC-225-SA-BV-GAP
- VPC-225-DA-BV
- VPC-225-DA-SN

www.vrgcontrols.com

VPC SPRING CONTROL RANGE LABEL



VRG CONTROLS
Solutions for Natural Gas

225 Pressure Series - Spring Control Range

Control Range	Color	Part No.
<input type="checkbox"/> 3 - 15 psig (9 - 97 kPa)	Black	CS-0100
<input type="checkbox"/> 5 - 53 psig (34 - 365 kPa)	Brown	CS-0110
<input type="checkbox"/> 16 - 100 psig (110 - 689 kPa)	Grey	CS-0120
<input checked="" type="radio"/> 40 - 170 psig (276 - 1172 kPa)	Orange	CS-0130
<input type="checkbox"/> 65 - 205 psig (448 - 1413 kPa)	White	CS-0135
<input type="checkbox"/> 100 - 225 psig (689 - 1551 kPa)	Purple	CS-0400

www.vrgcontrols.com

TABLE 3.0 VPC CONTROLLER SPRING RANGES AND PERFORMANCE SPECIFICATIONS

VPC Pressure Series	Control Range	Spring Color	Setpoint Change Per Rev.	Setpoint Accuracy ¹	Maximum "GAP" Setpoint Range ²	Control Spring Part No.
VPC-225 Pressure Series	3 - 15 psig (21 - 103 kPa)	Black	0.8 psig (5.5 kPa)	±0.1 psig (±0.7 kPa)	0.1 - 0.6 psig (0.7 - 4.0 kPa)	CS-0100
	5 - 53 psig (55 - 365 kPa)	Brown	3.1 psig (21.4 kPa)	±0.2 psig (±0.7 kPa)	0.2 - 2.3 psig (1.4 - 15.9 kPa)	CS-0110
	16 - 100 psig (110 - 689 kPa)	Grey	8 psig (55 kPa)	±0.3 psig (1.0 kPa)	0.5 - 6 psig (3.4 - 41 kPa)	CS-0120
	40 - 170 psig (276 - 1172 kPa)	Orange	20.2 psig (139 kPa)	±0.4 psig (±2.6 kPa)	1 - 15 psig (6.9 - 103 kPa)	CS-0130
	65 - 205 psig (448 - 1413 kPa)	White	32.2 psig (222 kPa)	±0.6 psig (±4.2 kPa)	2 - 24 psig (14 - 165 kPa)	CS-0135
	100 - 225 psig (689 - 1551 kPa)	Purple	44.2 psig (305 kPa)	±0.8 psig (±5.6 kPa)	3 - 34 psig (21 - 234 kPa)	CS-0140
VPC-700 Pressure Series	9 - 45 psig (62 - 310 kPa)	Black	2.4 psig (17 kPa)	±0.5 psig (±3.4 kPa)	0.5 - 1.9 psig (3.4 - 14 kPa)	CS-0100
	30 - 160 psig (241 - 1103 kPa)	Brown	9.6 psig (73 kPa)	±0.7 psig (±4.5 kPa)	1.5 - 8 psig (10 - 55 kPa)	CS-0110
	75 - 310 psig (517 - 2137 kPa)	Grey	24.5 psig (175 kPa)	±1.6 psig (±10 kPa)	3 - 20 psig (21 - 137 kPa)	CS-0120
	150 - 520 psig (1034 - 3585 kPa)	Orange	62.1 psig (423 kPa)	±3.8 psig (±26 kPa)	5 - 49 psig (35 - 337 kPa)	CS-0130
	240 - 635 psig (1655 - 4378 kPa)	White	98.9 psig (687 kPa)	±6.2 psig (±43 kPa)	6 - 80 psig (41 - 552 kPa)	CS-0135
	350 - 700 psig (2413 - 4826 kPa)	Purple	135.9 psig (926 kPa)	±8.3 psig (±57 kPa)	8 - 107 psig (69 - 276 kPa)	CS-0140
VPC-1500 Pressure Series	30 - 90 psig (207 - 620 kPa)	Black	5.0 psig (34 kPa)	±5.0 psig (±34 kPa)	N/A ³	CS-0100
	50 - 335 psig (345 - 2309 kPa)	Brown	19.7 psig (149 kPa)	±5.0 psig (±34 kPa)	N/A ³	CS-0110
	100 - 640 psig (689 - 4412 kPa)	Grey	50.4 psig (361 kPa)	±5.0 psig (±34 kPa)	10 - 40 psig (69 - 276 kPa)	CS-0120
	265 - 1070 psig (1827 - 7377 kPa)	Orange	127.6 psig (870 kPa)	±7.8 psig (±54 kPa)	10 - 100 psig (69 - 690 kPa)	CS-0130
	400 - 1300 psig (2758 - 8962 kPa)	White	203.2 psig (870 kPa)	±13 psig (±88 kPa)	15 - 163 psig (103 - 1125 kPa)	CS-0135
	625 - 1500 psig (4309 - 10341 kPa)	Purple	279.3 psig (1904 kPa)	±17 psig (±118 kPa)	20 - 220 psig (138 - 1522 kPa)	CS-0140

NOTES

1. Setpoint Accuracy based upon proper maintenance of VPC Controller and adjustment to specification following VPC Controller Technical Manual. Setpoint Accuracy represents maximum control band over 24 hours when VPC utilized WITHOUT volume booster or pneumatic positioner. When VPC utilized WITH volume booster or pneumatic positioner accuracy increases and value should be multiplied by 0.5.

2. Maximum "GAP" Setpoint Range applicable only to VPC-GAP Controller Configurations. The "GAP" relates to bracketed high-low trigger points for discrete on-off control logic.

3. These Control Springs not recommended for this particular model of VPC GAP Controller.

TABLE 4.0 CRITICAL FLOW EQUATION

$$Q_c = 312.9 \times (P_1 + 14.7) \times C_v \times \sqrt{\frac{1}{G \times (T + 460)}}$$

Where:

Variable	Description	Unit
Q _c	Critical Flow Across Inlet Orifice	scfh
P ₁	Supply Pressure	psig
C _v	Flow Factor	--
G	Specific Gravity of Gas	--
T	Gas Temperature	*F

TABLE 5.0 FLOW COEFFICIENT TABLE (CV)

Adjustable Orifice Flow Coefficients

Adjustable Orifice Setting								
Installed Orifice	0	1	2	3	4	5	6	7
Standard	0.006	0.009	0.018	0.044	0.069	0.096	0.111	0.126
Medium (M)	0.042	0.045	0.062	0.089	0.134	0.172	0.211	0.249
Large (L)	0.042	0.063	0.172	0.328	0.461	0.578	0.634	0.675

Notes:

- Equation above may be utilized to determine supply regulator consumption requirements and steady state bleed rates for control valves operated with a VPC BV Valve Pilot Controller.
- When applications do not utilize Adjustable Orifice, then the VPC internal Balanced Valve becomes the limiting factor to determine flow rates and resultant stroking times. VPC Internal Balanced Valve C_v=1.45.

TABLE 6.0 ESTIMATED TRAVEL TIME

$$t = 0.148 \times \frac{H \times D^2}{C_v} \times \sqrt{\frac{G}{T + 460}}$$

Where:

Variable	Description	Unit
t	Stroke Time	Sec.
H	Actuator Cylinder Stroke Length	in.
D	Actuator Cylinder Diameter	in.
C _v	Limiting Flow Coefficient	--
G	Gas Specific Gravity	Typ. 0.6 Natural Gas
T	Gas Temperature	*F

HOW IT WORKS DESCRIPTIONS:**DIRECT ACTING VPC-SA-BV**

When the SENSING pressure is equal to the VPC setpoint, the net force on the VPC power module is zero. This is the equilibrium or "balanced" condition where the sensing pressure that pushes down on the sensing diaphragm and the control spring force that pulls up on the sensing diaphragm are equal. When the VPC achieves equilibrium, the SUPPLY balanced valve and EXHAUST balanced valve assemblies will remain closed maintaining a constant OUTPUT pressure to the control valve. The VPC will exhibit ZERO emissions at this state. From this position two possible scenarios can occur, the sensing pressure can rise above or below the set point.

If the sensing pressure rises above the VPC setpoint the net force on the VPC power module is downward. The EXHAUST balance valve will close. The SUPPLY balance valve opens, increasing the flow of SUPPLY gas to the OUTPUT port. The combination of these actions creates a rise in output pressure. If the sensing pressure falls below the VPC setpoint the net force on the VPC power module is upward. Now the SUPPLY balanced valve will close. The EXHAUST balanced valve opens, increasing the flow of gas to the EXHAUST port. The combination of these actions decreases the OUTPUT pressure. In order to control how much gas passes through the balanced valve, adjustable orifices are installed to restrict the flow via the SUPPLY and the EXHAUST.

DIRECT ACTING VPC-SA-BV-ID

The VPC is inherently an INTEGRAL function device. A DERIVATIVE function may be added to the OUTPUT of the VPC by incorporating a VOLUME TANK in conjunction with an adjustable orifice on the OUTPUT signal. The DERIVATIVE component affects the rate at which the OUTPUT signal change is applied to the control valve unit. If the DERIVATIVE orifice number is increased this will cause a slower resultant change in OUTPUT pressure (signal) to the control valve. Conversely, if the DERIVATIVE orifice number is decreased it will permit a more rapid change in OUTPUT pressure (signal) to the control valve unit. The DERIVATIVE function is typically incorporated to introduce additional stability when the VPC is applied in conjunction with a pneumatic valve positioner or when the installed system is has a rapidly affected downstream system such as a power plant fuel gas feed or two-stage pressure cut application.

REVERSE ACTING VPC-SA-BV-ID

In this case, the SUPPLY pressure and the EXHAUST pressure are routed differently by changing the ORIFICE manifolds. The VPC will exhibit behavior in a "reverse" scenario. When SENSING pressure rises above the set point the net force on the VPC power module pushes downward. The SUPPLY balanced valve will close and the EXHAUST balanced valve will open, causing gas to vent through the EXHAUST port. This results in a decrease of OUTPUT pressure. If the SENSING pressure falls below the VPC setpoint, the net force on the VPC power module is upward. The SUPPLY balanced valve will open and the EXHAUST balanced valve will close causing an increase in OUTPUT pressure. Any VPC "Single

Acting" model maybe easily converted between Direct Acting and Reverse Acting by simply swapping the position of the SUPPLY/EXHAUST and OUTPUT manifolds.

VPC-SA-BV-GAP

For "How it Works" description of the VPC-SA-BV-GAP, reference Direct Acting VPC-SA-BV at top of this page. The VPC-SA-BV-GAP will differ in construction by not having ADJUSTABLE ORIFICES installed. The "GAP Controller" will differ operationally as it operates with a "snap acting" or "on-off" logic. The "on-off" logic produces a HIGH SETPOINT and LOW SETPOINT which area separated by a "BAND." This "BAND" or difference between the two (2) setpoints is achieved by widening the deadband via the SETPOINT ADJUSTMENT DRUM.

DOUBLE ACTING VPC-DA-BV

When the SENSING pressure is equal to the VPC-DA-BV setpoint, the net force on the VPC-DA-BV power module is zero. This is the equilibrium or "balanced" condition where the sensing pressure that pushes down on the sensing diaphragm and the control spring force that pulls up on the sensing diaphragm are equal. When the VPC-DA-BV achieves equilibrium, the OPEN balanced valve and CLOSE balanced valve assemblies will remain closed maintaining a constant OUTPUT pressure to the top and bottom chambers of the control valve actuator.

From this position two possible scenarios can occur, the sensing pressure can rise above or below the set point. If the sensing pressure rises above the VPC-DA-BV setpoint the net force on the VPC-DA-BV power module is downward. The OPEN balance valve will open and divert pressure from the OPEN chamber of the double acting actuator to EXHAUST. The CLOSE balance valve will remain closed and full SUPPLY pressure shall continue to be applied to the CLOSE side of the double acting actuator. The combination of these actions creates a differential pressure to be applied to the double acting actuator that will move the valve toward the closed position.

If the sensing pressure falls below the VPC-DA-BV setpoint the net force on the VPC-DA-BV power module is upward. The CLOSE balance valve will open and divert pressure from the CLOSE chamber of the double acting actuator to EXHAUST. The OPEN balance valve will remain closed and full SUPPLY pressure shall continue to be applied to the OPEN side of the double acting actuator. The combination of these actions creates a differential pressure to be applied to the double acting actuator that will move the valve toward the open position.

Addition of an NVD No-Vent Device will eliminate emissions when the control valve remains in the full-open or full-closed positions such as a standby, overpressure monitor or relief type application.

TABLE 7.0 VPC INITIAL ADJUSTMENT PROCEDURE SUMMARY (SINGLE ACTING UNITS VPC-SA-BV & VPC-SA-BV-ID)

Step	VPC Component	Adjustment Action or Observation		Notes
		VPC-SA-BV VPC-SA-BV-ID DIRECT ACTING	VPC-SA-BV VPC-SA-BV-ID REVERSE ACTING	
1	SENSING Pressure	CLOSE + VENT		SENSING VALVES must be 100% bubble tight for successful adjustment
2	OUTPUT Valve(s)	CLOSE		OUTPUT VALVES must be 100% bubble tight for successful adjustment
3	SUPPLY Regulator	Adjust to Required Pressure		Refer to Actuator or Positioner Manufacturer for Details
4	SETPPOINT ADJUST SCREW	Counterclockwise → CCW to unload Control Spring Then Clockwise ← 2.0 Turns		When CONTROL SPRING unloaded torque will decrease noticeably
5	ADJUST DRUM	→ RIGHT until STOP then ← 2.75 Turns		Do not apply excessive force
6	SENSING PRESSURE	Apply Required Setpoint Pressure (False Signal)		Recommended to utilize accurate calibrated gage
7	SETPPOINT ADJUST SCREW	← CW until OUTPUT PRESSURE begins to DECREASE ↓.	← CW until OUTPUT PRESSURE begins to INCREASE ↑	Output Pressure Should be steady between ZERO and 100% SUPPLY PRESSURE
8	EXHAUST	Check if EXHAUST venting		Inspect EX Port(s). Remove VENT fitting for easy verification.
9	ADJUST DRUM	If EXHAUST vents, then ← LEFT (Numbers Increase) until EXHAUST vent just stops		Inspect EX Port(s) while adjusting.
10	ADJUST DRUM	If NO EXHAUST vent, then → RIGHT (Numbers Decrease) until EXHAUST vent just starts. • Then ← LEFT (Numbers Increase) until EXHAUST vent just stops.		Inspect EX Port(s) while adjusting
11	SETPPOINT ADJUST SCREW	Rotate ← CW OR → CCW to establish setpoint. Setpoint achieved when OUTPUT PRESSURE remains steady between ZERO and 100% SUPPLY PRESSURE		Rotate back & forth to achieve
12	ADJUST DRUM	If EXHAUST vents, then ← LEFT (Numbers Increase) until EXHAUST vent just stops		Inspect EX Port(s) while adjusting
13	ADJUST DRUM	If NO EXHAUST from vent then → RIGHT (Numbers Decrease) until EXHAUST vent just starts. • Then ← LEFT (Numbers Increase) until EXHAUST vent just stops.		Inspect EX Port(s) while adjusting
14	OUTPUT Pressure	Output Pressure Should be steady between ZERO and 100% SUPPLY PRESSURE		Initial Adjustment Achieved. Refer to Application Based Fine Tuning Setting Guidelines (Section 10) for Application Specific Secondary Tuning.
15	EXHAUST	EXHAUST port exhibits 10-30 seconds bubble		

NOTE 1: For VPC-SA-BV-GAP units, follow Steps 1 through 13 and then adjust the GAP setting as follows. Rotate the SENSITIVITY ADJUSTMENT DRUM to LEFT (Increasing Numbers) to increase GAP range. Rotate the SENSITIVITY ADJUSTMENT DRUM to RIGHT (Decreasing Numbers) to reduce GAP range. The SETPOINT ADJUSTMENT SCREW is utilized to elevate or lower the HIGH TRIGGER setpoint

NOTE 2: For VPC-SA-BV-GAP units, establish the LOW TRIGGER setpoint via the SENSITIVITY ADJUSTMENT DRUM. Then establish the HIGH TRIGGER setpoint via the SETPOINT ADJUSTMENT SCREW. Using an iterative process, the SENSITIVITY ADJUSTMENT DRUM and SETPOINT ADJUSTMENT SCREW may be utilized to achieve desired HI TRIGGER and LOW TRIGGER setpoints.

TABLE 8.0 VPC INITIAL ADJUSTMENT PROCEDURE SUMMARY (DOUBLE ACTING UNITS VPC-DA-BV)

VPC-DA-BV

Step	VPC Component	Adjustment Action or Observation	Notes
1	SENSING PRESSURE	CLOSE + VENT	SENSING VALVES must be 100% bubble tight for successful adjustment
2	OUTPUT VALVE(S)	CLOSE	OUTPUT VALVES must be 100% bubble tight for successful adjustment
3	SUPPLY REGULATOR	Adjust to Required Pressure	Refer to Actuator or Positioner Manufacturer for Details
4	SETPPOINT ADJUST SCREW	Counterclockwise → CCW to unload Control Spring Then Clockwise ← 2.0 Turns	When CONTROL SPRING unloaded torque will decrease noticeably
5	ADJUST DRUM	→ RIGHT until STOP then ← 2.75 Turns	Do not apply excessive force
6	SENSING PRESSURE	Apply Required Setpoint Pressure (False Signal)	Recommended to utilize accurate calibrated gage
7	SETPPOINT ADJUST SCREW	CW until Cyl. close pressure begins to decrease	Cyl open and cyl close pressure must be equal
8	OUTPUT PRESSURE	Check output pressure values.	Cyl open and cyl close pressure must be equal
9	ADJUST DRUM	If EXHAUST vents, then ← LEFT (Numbers Increase) until EXHAUST vent just stops	Inspect EX Port(s) while adjusting.
10	ADJUST DRUM	If NO EXHAUST vent, then → RIGHT (Numbers Decrease) until EXHAUST vent just starts. • Then ← LEFT (Numbers Increase) until EXHAUST vent just stops.	Inspect EX Port(s) while adjusting
11	SETPPOINT ADJUST SCREW	Set point achieved when output pressures are equal	Rotate back & forth to achieve
12	OUTPUT PRESSURE	Output pressure should be equal	Pilot is at set point.
13	EXHAUST	EXHAUST port exhibits 10-30 seconds bubble	Pilot at Zero Dead Band
14	ADJUST DRUM	Rotate right (numbers decrease) to (-1/4).	Pilot at 98% output

NOTES

1. Adjustment and Installation of VRG Controls equipment should be only be performed by qualified personnel adequately trained and familiar with products.
2. For technical assistance, please contact your local VRG Controls Sales Representative or VRG Controls direct (www.vrgcontrols.com).

TABLE 9.0 VPC INITIAL ADJUSTMENT PROCEDURE SUMMARY (SINGLE ACTING VPC)

APPLICATION	Recommended VPC Model	Ball Valve	Globe Valve	DA Actuator	SR Actuator	Volume Booster	Pneumatic Positioner	Close Orifice	Open Orifice	D Tank Orifice	Dead Band
PIPELINE INTERCONNECT	VPC-SA-BV	■			■	N	N	L6	L6	N/A	0
								L6	L6	N/A	-1/4
	VPC-SA-BV-ID	■			■	Y	N	S3	S3	S3	0
								S6	S3	S2	0
	VPC-SA-BV-ID	■			■	N	Y	S3	S3	S3	+1/4
								S5	S3	S2	0
	VPC-SA-BV	■		■		N	Y	S3	S3	S3	+1/4
								S5	S3	S2	0
	VPC-SA-BV-ID			■	■	N	N	M6	M6	N/A	0
								L6	L6	N/A	-1/4
	VPC-SA-BV-ID			■	■	Y	N	S3	S3	S3	+1/8
								S5	S3	S2	0
	VPC-SA-BV-ID			■	■	N	Y	S3	S3	S3	+1/4
								S5	S3	S2	0
VPC-SA-BV-ID			■	■	N	Y	S3	S3	S3	+1/4	
							S5	S3	S2	0	
POWERPLANT/INDUSTRIAL SERIES CLOSE-COUPLED SYSTEMS	VPC-SA-BV-ID	■			■	Y	N	S4	S3	S2	0
								S6	S3	S2	0
	VPC-SA-BV-ID	■			■	N	Y	S4	S3	S2	+1/4
								S6	S3	S2	0
	VPC-SA-BV-ID	■		■	■	N	Y	S4	S3	S2	+1/4
								S5	S3	S2	0
	VPC-SA-BV-ID			■	■	Y	N	S4	S3	S2	+1/8
								S5	S3	S2	0
	VPC-SA-BV-ID			■	■	N	Y	S4	S3	S2	+3/8
								S5	S3	S2	0
	VPC-SA-BV-ID			■	■	N	Y	S4	S3	S2	+3/8
								S5	S3	S2	0
	VPC-SA-BV-ID			■	■	N	N	L6	L3	S2	0
								L6	L3	S2	-1/4

NOTES

1. Adjustment and Installation of VRG Controls equipment should be only be performed by qualified personnel adequately trained and familiar with products.
2. For technical assistance, please contact your local VRG Controls Sales Representative or VRG Controls direct (www.vrgcontrols.com).
3. All values represent a starting point. Dynamic tuning with VPC in "live control" will be necessary to optimize performance.
4. In this table, Pipeline Interconnects are defined >1.0 mile downstream piping adjacent to control valve.
5. In this table, Close-Coupled System Applications are defined <1.0 mile downstream piping adjacent to control valve.
6. Increasing number on the SUPPLY & EXHAUST ORIFICE will increase the speed of response independently in each direction (faster reset rate).

7. Refer to VPC Application Schematic to determine which Adjustable Orifice controls OPEN and CLOSE speed.
7. Increasing number on the "D" TANK ORIFICE will introduces a DERIVATIVE function controls the RATE of OUTPUT. Larger DERIVATIVE number of "D" TANK Adjustable Orifice introduces more dampening of the OUTPUT.
8. If stable control is achieved upon adjusting the VPC per the above guidelines, the deadband may be reduced (smaller number on Sensitivity Adjusting Drum). For dynamic systems, do not reduce deadband to less than "ZERO" as defined in Initial Adjustment Procedures.
9. If system is unstable upon adjusting VPC per above guidelines, corrective adjustment to INCREASE CLOSING speed and REDUCE OPENING speed are suggested. Additionally, the deadband may be increased (larger number on Sensitivity Adjusting Drum).
10. Top row - Worker // Bottom Row - Monitor

TABLE 10.0 VPC-SA-BV-ID APPLICATIONS WITH TWO VALVES WORKER TRIMMER FOR POWER PLANTS

	BALL VALVE	GLOBE VALVE	DA ACTUATOR	SR ACTUATOR	VOLUME BOOSTER	PNEUMATIC POSITIONER	CLOSE ORIFICE	OPEN ORIFICE	D TANK ORIFICE	DEAD BAND
WORKER	■			■	■		S4	S3	S2	+1/4
TRIMMER		■		■			L5	L3	S2	-1/4
WORKER	■			■		■	S3	S2	S2	+3/8
TRIMMER		■		■			L5	L5	S2	-1/4
WORKER		■	■			■	S3	S3	S3	+1/2
TRIMMER		■		■			L5	L5	S2	-1/4
WORKER		■		■			L6	L5	S1	+1/2
TRIMMER		■		■			L5	L3	S2	-1/4
WORKER		■		■	■		S4	S3	S2	+1/2
TRIMMER		■		■			L5	L3	S2	-1/4
WORKER		■		■		■	S3	S2	S2	+1/2
TRIMMER		■		■			L5	L3	S2	-1/4

NOTES:

1. The above values represent the starting point. In the event the system is unstable, slow down the workers and increase the sensitivity of the trimmer.
2. The set point of the trimmer is set inside the dead band of the worker.

TABLE 11.0 APPLICATION BASED FINE TUNING SETTING GUIDELINES – VPC DOUBLE ACTING

Application	Recommended VPC Model	Ball Valve	Globe Valve	Actuator Volume	DA Actuator	CLOSE Orifice	OPEN Orifice	Dead Band	Notes
Pipeline Interconnect	VPC-DA-BV	■	■	≤ 80 in ³	■	3	3	“98%” (-1/4)	
	VPC-DA-BV	■	■	> 80 in ³ ≤ 400 in ³	■	4	4	“98%” (-1/4)	
	VPC-DA-BV	■	■	> 400 in ³ ≤ 950 in ³	■	5	5	“98%” (-1/4)	
	VPC-DA-BV	■	■	> 950 in ³	■	NR	NR	NR	1

NOTES

1. For ACTUATOR VOLUME greater than 950 in³ utilize VPC-DA-SN with Volume Boosters. Contact VRG for additional details.
2. Adjustment and Installation of VRG Controls equipment should be only be performed by qualified personnel adequately trained and familiar with products.
3. For technical assistance, please contact your local VRG Controls Sales Representative or VRG Controls direct (www.vrgcontrols.com).
4. All values represent a starting point. Dynamic tuning with VPC in “live control” will be necessary to optimize performance.

TABLE 12.0 VPC ASSEMBLY CONFIGURATION SUMMARY

Component	VPC-SA-BV (Reverse)	VPC-SA-BV (Direct)	VPC-SA-BV-ID (Reverse)	VPC-SA-BV-ID (Direct)	VPC-SA-BV-GAP (Reverse)	VPC-SA-BV-GAP (Direct)	VPC-DA-BV
Output	SA	SA	SA	SA	SA	SA	DA
Internal Valve Logic	BV	BV	BV	BV	BV	BV	BV
Action	Reverse	Direct	Reverse	Direct	Reverse	Direct	--
Cartridge Top Flange	1	1	1	1	1	1	1
Spring Cartridge	2	2	2	2	2	2	2
700 Sensing Spacer	3	3	3	3	3	3	3
225/1500 Spacer Flange/Adapter	3A	3A	3A	3A	3A	3A	3A
225/1500 Sensing Spacer	3B	3B	3B	3B	3B	3B	3B
Pilot Block (TOP)	■	■	■	■	■	■	■
Pilot Block (BOTTOM)	●	●	●	●	●	●	●
Pilot Spacer (TOP)	4	4	4	4	4	4	4
Pilot Spacer (BOTTOM)	5	5	5	5	5	5	5
Pilot Block (TOP)	●	●	●	●	●	●	●
Pilot Block (Bottom)	■	■	■	■	■	■	▼
Pilot Bottom Flange	7	7	7	7	7	7	7
Left Hand Manifold	EX S	OUT	EX S	T OUT	EX S	OUT	EX
Right Hand Manifold	OUT	S EX	OUT T	S EX	OUT	S EX	S
DA Output Manifold	--	--	--	--	--	--	OUT1 OUT2

VPC-700-SA-BV (Reverse Acting) Assembly Guide
Part Number: PA-0040

VPC-700-SA-BV (Direct Acting) Assembly Guide
Part Number: PA-0030

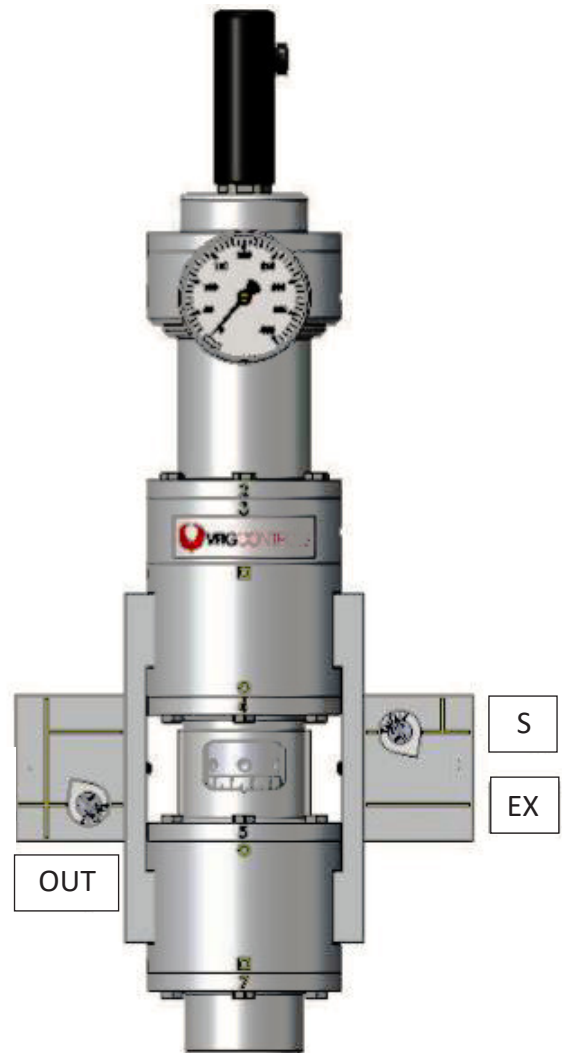

1. Remote Loading to the bottom of the pilot is available by adding the sensing assy to the bottom of the pilot.

- PA-0080 Sensing assy-700
- PA-0090 Sensing assy-1500
- PA-0100 Sensing assy-225

VPC-SA-BV-ID (Reverse Acting) Assembly Guide
Part Number: PA-0043

VPC-SA-BV-ID (Direct Acting) Assembly Guide
Part Number: PA-0044

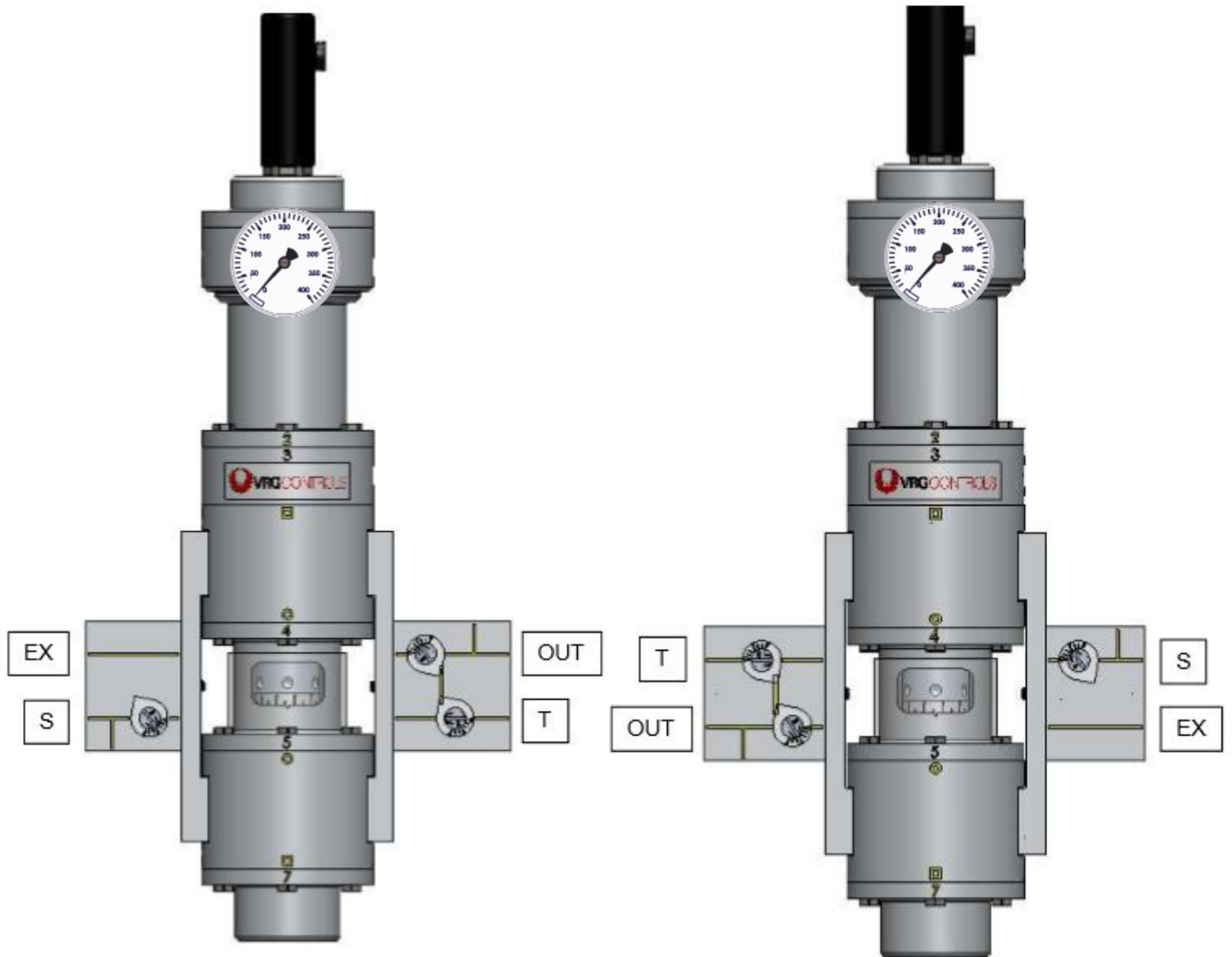

1. Remote Loading to the bottom of the pilot is available by adding the sensing assy to the bottom of the pilot.

- PA-0080 Sensing assy-700
- PA-0090 Sensing assy-1500
- PA-0100 Sensing assy-225

VPC-SA-BV-GAP (Reverse Acting) Assembly Guide
Part Number: PA-0042

VPC-SA-BV-GAP (Direct Acting) Assembly Guide
Part Number: PA- 0035

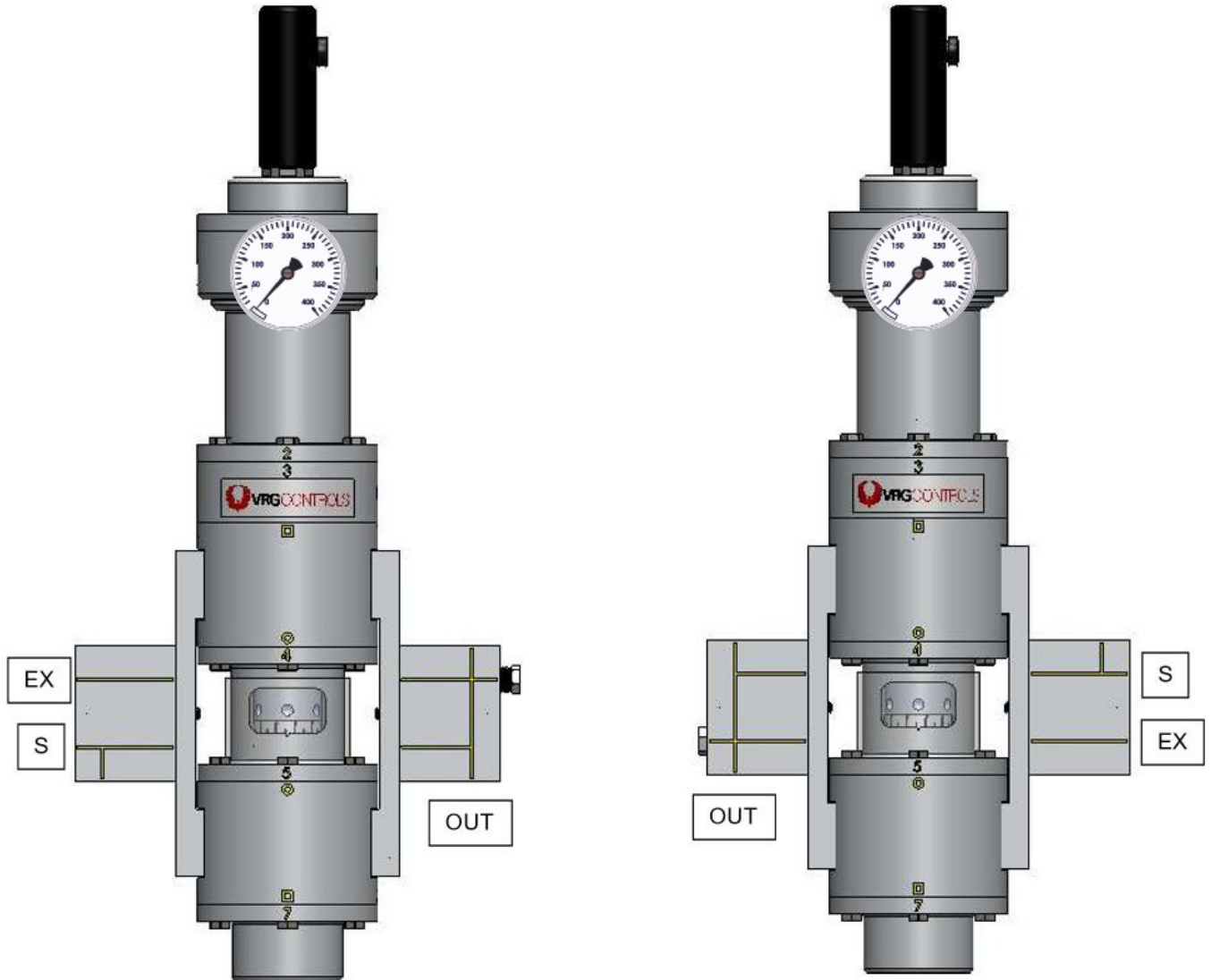

1. Remote Loading to the bottom of the pilot is available by adding the sensing assy to the bottom of the pilot.

PA-0080 Sensing assy-700
PA-0090 Sensing assy-1500
PA-0100 Sensing assy-225

VPC-DA-BV (Double Acting) Assembly Guide
Part Number: PA-0010

VPC-DA-BV-NVD (Double Acting) Assembly Guide
Part Number: PA-0015

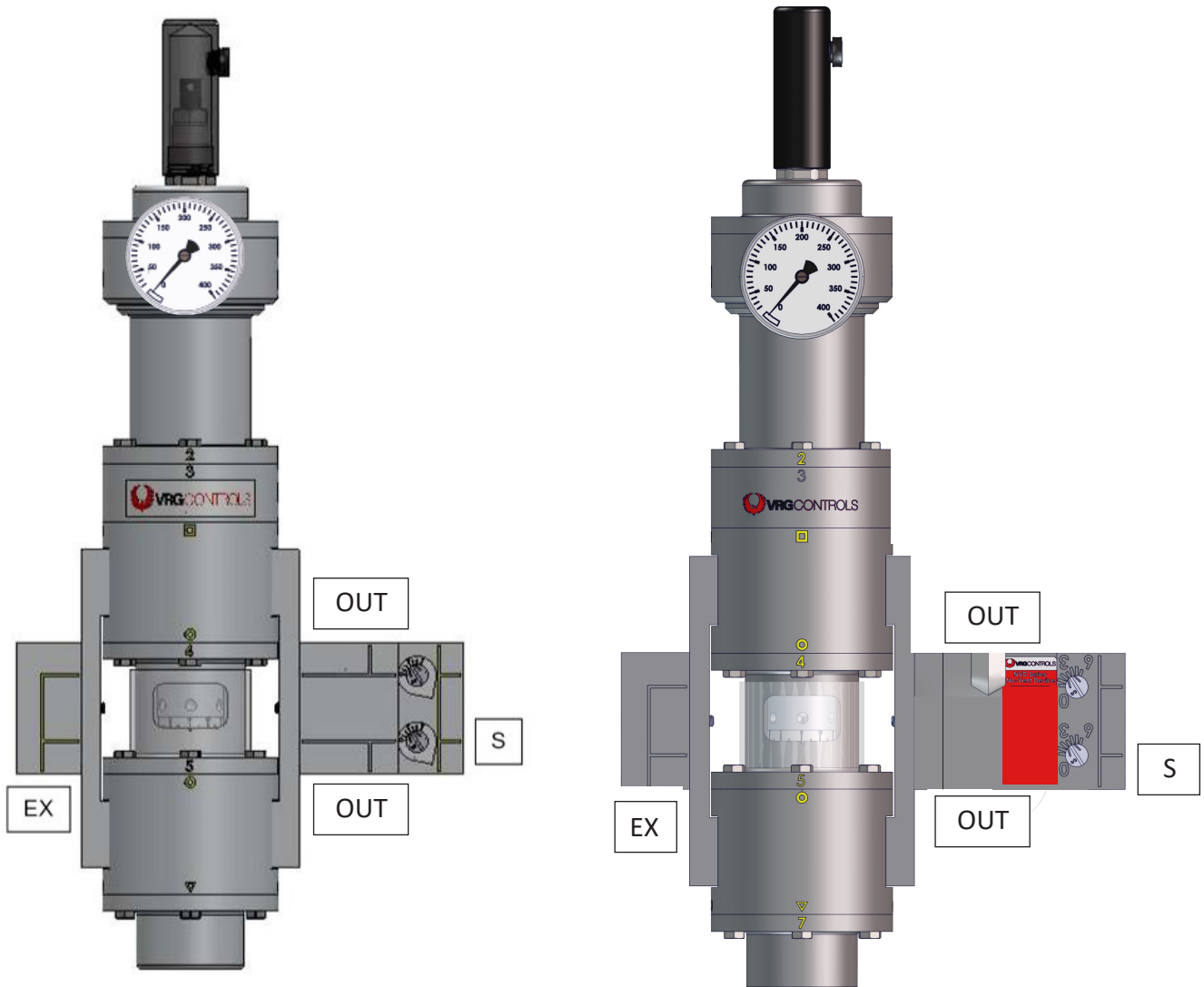

1. Remote Loading to the bottom of the pilot is available by adding the sensing assy to the bottom of the pilot.

- PA-0080 Sensing assy-700
- PA-0090 Sensing assy-1500
- PA-0100 Sensing assy-225

TABLE 13.0 VPC-BV (BALANCED VALVE TYPE) REPAIR KIT BILL OF MATERIALS BOM PACKING LIST

Packed Date	Packed By	QC
-------------	-----------	----

Repair Kit	Part No.	Notes:
VPC-BV Repair Kit	RK-0100	

This Repair Kit Fits Following VRG Models:

VPC-225-SA-BV	VPC-700-SA-BV	VPC-1500-SA-BV
VPC-225-SA-BV-ID	VPC-700-SA-BV-ID	VPC-1500-SA-BV-ID
VPC-225-SA-BV-GAP	VPC-700-SA-BV-GAP	VPC-1500-SA-BV-GAP
VPC-225-DA-BV	VPC-700-DA-BV	VPC-1500-DA-BV

Item	Part Number	Description	Type	QTY	CHK
1	EL-0010	Diaphragm whole-700 psig, Buna	Diaphragms	5	<input type="checkbox"/>
2	EL-0020	Diaphragm whole-1500 psig, Buna	Diaphragms	1	<input type="checkbox"/>
3	EL-0030	Diaphragm whole-255 psig, Buna	Diaphragms	1	<input type="checkbox"/>
4	EL-0200	O-Ring, -010, Buna, 3/8x1/4x1/16	O-Rings	10	<input type="checkbox"/>
5	EL-0210	O-Ring, -012, Buna, 1/2x3/8x1/16	O-Rings	11	<input type="checkbox"/>
6	EL-0220	O-Ring, -014, Buna, 5/8x1/2x1/16	O-Rings	5	<input type="checkbox"/>
7	EL-0230	O-Ring, -109, Buna, 1/2x5/16x3/32	O-Rings	1	<input type="checkbox"/>
8	EL-0235	O-Ring, -112, Buna, 11/16x1/2x3/32	O-Rings	4	<input type="checkbox"/>
9	EL-0237	O-Ring, -116, Buna, 15/16x3/4x3/32	O-Rings	1	<input type="checkbox"/>
10	EL-0240	O-Ring, -147, Buna, 2-7/8x2-11/16x3/32	O-Rings	2	<input type="checkbox"/>
11	PD-0170	Balanced Valve Assembly	Internals	2	<input type="checkbox"/>
12	PD-0240	Balanced Valve Seat	Internals	2	<input type="checkbox"/>
13	PD-0260	Balanced Valve Spacer Screen	Internals	2	<input type="checkbox"/>
14	N/A	Mobilith SHC 220 Standard VRG Lubricant	Lubricant	1	<input type="checkbox"/>
15	PD-0490	NPT Block Test Manifold	Tool	1	<input type="checkbox"/>

TABLE 14.0 FACTORY QUALITY CHECKLIST VPC VALVE PILOT CONTROLLER

Date:
VRG Invoice Number:
Personnel:
Model Number:
Serial Number:
Customer:
Customer Tag:
Supply Pressure
Discharge Pressure
Orifice Setting _____ <input type="checkbox"/> Output <input type="checkbox"/> Open <input type="checkbox"/> Close <input type="checkbox"/> Supply
Orifice Setting _____ <input type="checkbox"/> Output <input type="checkbox"/> Open <input type="checkbox"/> Close <input type="checkbox"/> Supply
Orifice Setting _____ <input type="checkbox"/> Derivative Adjustment

Procedure	Verified	Notes
Apply Maximum Sensing Pressure 30 min.	<input type="checkbox"/> VERIFY	
Adjust VPC to Setpoint	<input type="checkbox"/> VERIFY	
Friction Test	<input type="checkbox"/> VERIFY	
Gage Check	<input type="checkbox"/> VERIFY	
Valve Leak Check	<input type="checkbox"/> VERIFY	
Assembly Leak Check	<input type="checkbox"/> VERIFY	
Sensitivity/Deadband Adjustment (Initial)	<input type="checkbox"/> VERIFY	
Sensitivity/Deadband Adjustment (Adjusted)	<input type="checkbox"/> VERIFY	
Sensitivity Check	<input type="checkbox"/> VERIFY	
Label Check	<input type="checkbox"/> VERIFY	

Notes:

TABLE 15.0 VPC APPLICATION SCHEMATICS TABLE OF CONTENTS

No.	VPC	Actuator	Actuator Mode	Positioner	Accessory	Discharge	Page
1	VPC-DA-BV (DA)	PISTON	DA	-	-	ATM	22
1A	VPC-DA-BV (DA)	PISTON	DA	-	VMO	ATM	23
2	VPC-DA-BV(DA)	PISTON	DA	-	-	NVD-NO VENT	24
2A	VPC-DA-BV (DA)	PISTON	DA	-	VMO	NVD-NO VENT	25
3	VPC-SA-BV (DIR)	SPRING PISTON	SPRING OPEN	-	-	ATM	26
3A	VPC-SA-BV (DIR)	SPRING PISTON	SPRING OPEN	-	VMO	ATM	27
4	VPC-SA-BV (REV)	SPRING PISTON	SPRING CLOSED	-	-	ATM	28
4A	VPC-SA-BV (REV)	SPRING PISTON	SPRING CLOSED	-	VMO	ATM	29
5	VPC-SA-BV (REV)	SPRING PISTON	SPRING CLOSED	-	Quick Exhaust	ATM	30
5A	VPC-SA-BV (REV)	SPRING PISTON	SPRING CLOSED	-	VMO, Quick Exhaust	ATM	31
6	VPC-SA-BV-ID (DIR)	SPRING PISTON	SPRING OPEN	CLOSE INCR	-	ATM	32
6A	VPC-SA-BV-ID (DIR)	SPRING PISTON	SPRING OPEN	CLOSE INCR	VMO	ATM	33
7	VPC-SA-BV-ID (REV)	SPRING PISTON	SPRING CLOSED	OPEN INCR	-	ATM	34
7A	VPC-SA-BV-ID (REV)	SPRING PISTON	SPRING CLOSED	OPEN INCR	VMO	ATM	35
8	VPC-SA-BV-ID (DIR)	SPRING PISTON	SPRING OPEN	-	BOOSTER	ATM	36
8A	VPC-SA-BV-ID (DIR)	SPRING PISTON	SPRING OPEN	-	BOOSTER + VMO	ATM	37
9	VPC-SA-BV- ID (REV)	SPRING PISTON	SPRING CLOSED	-	BOOSTER	ATM	38
9A	VPC-SA-BV-ID (REV)	SPRING PISTON	SPRING CLOSED	-	BOOSTER + VMO	ATM	39
10	VPC-SA-BV (DIR)	SPRING DIAPHRAGM	SPRING OPEN	-	-	ATM	40
10A	VPC-SA-BV (DIR)	SPRING DIAPHRAGM	SPRING OPEN	-	VMO	ATM	41
11	VPC-SA- BV (REV)	SPRING DIAPHRAGM	SPRING CLOSED	-	-	ATM	42
11A	VPC-SA-BV (REV)	SPRING DIAPHRAGM	SPRING CLOSED	-	VMO	ATM	43
12	VPC-SA-BV-ID (DIR)	SPRING DIAPHRAGM	SPRING OPEN	-	BOOSTER	ATM	44
12A	VPC-SA-BV ID (DIR)	SPRING DIAPHRAGM	SPRING OPEN	-	BOOSTER + VMO	ATM	45
13	VPC-SA-BV-ID (REV)	SPRING DIAPHRAGM	SPRING CLOSED	-	BOOSTER	ATM	46
13A	VPC-SA-BV-ID (REV)	SPRING DIAPHRAGM	SPRING CLOSED	-	BOOSTER + VMO	ATM	47
14	VPC-SA-BV-ID (DIR)	SPRING DIAPHRAGM	SPRING OPEN	-	-	ATM	48
14A	VPC-SA-BV-ID (DIR)	SPRING DIAPHRAGM	SPRING OPEN	-	VMO	ATM	49
15	VPC-SA-BV-ID (REV)	SPRING DIAPHRAGM	SPRING CLOSED	-	-	ATM	50
15A	VPC-SA-BV-ID (REV)	SPRING DIAPHRAGM	SPRING CLOSED	-	VMO	ATM	51
16	VPC-SA-GAP (DIR)	SPRING PISTON	SPRING CLOSED	-	3 WAY VLV	ATM	52

No. VPC	Actuator	Actuator Mode	Positioner	Accessory	Discharge
1 VPC-DA-BV (DA)	Piston	Double Acting	-	-	ATM

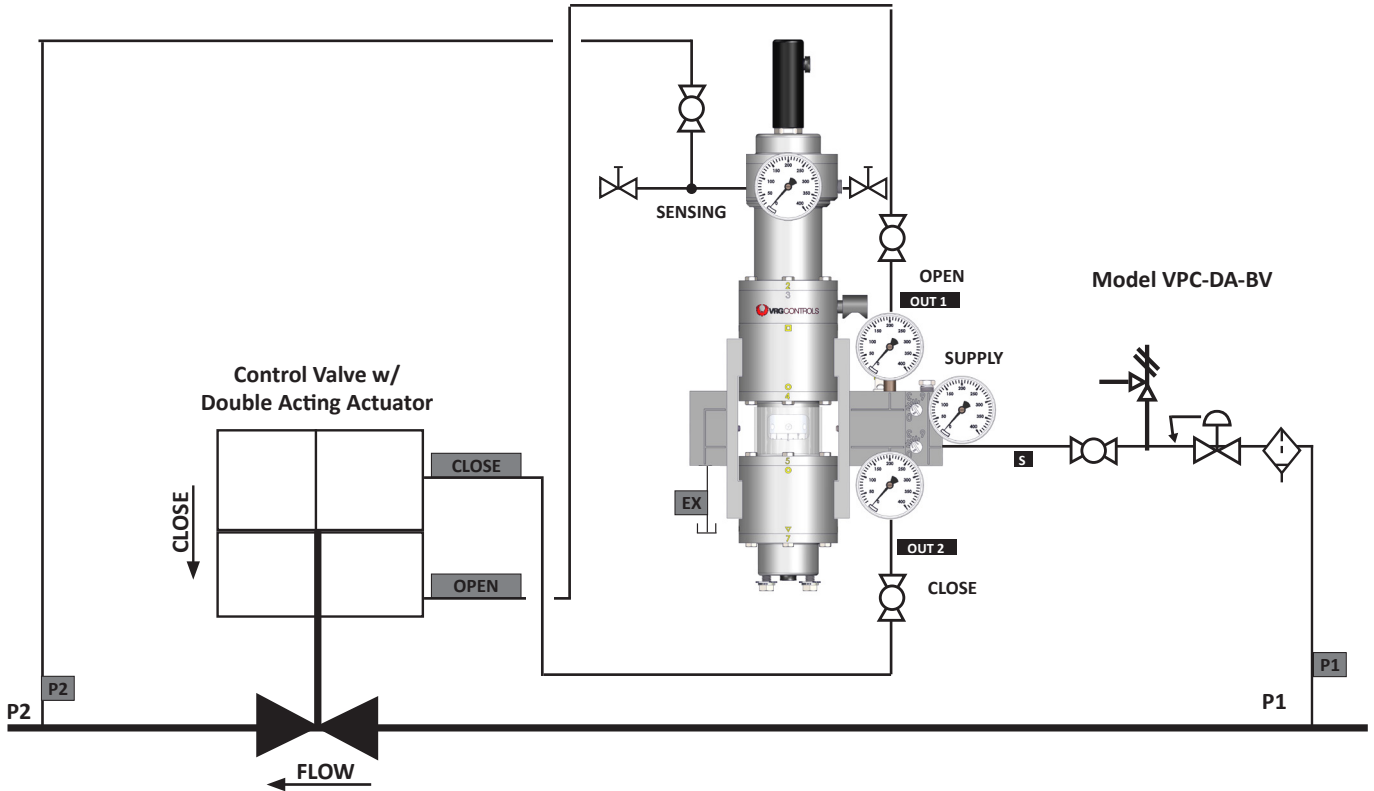

SCHEMATIC LEGEND

- TEXT VPC Port ID
- TEXT Other Port ID
- TEXT Gage Label
- Pneumatic Connection
- Adjustment Tag Line

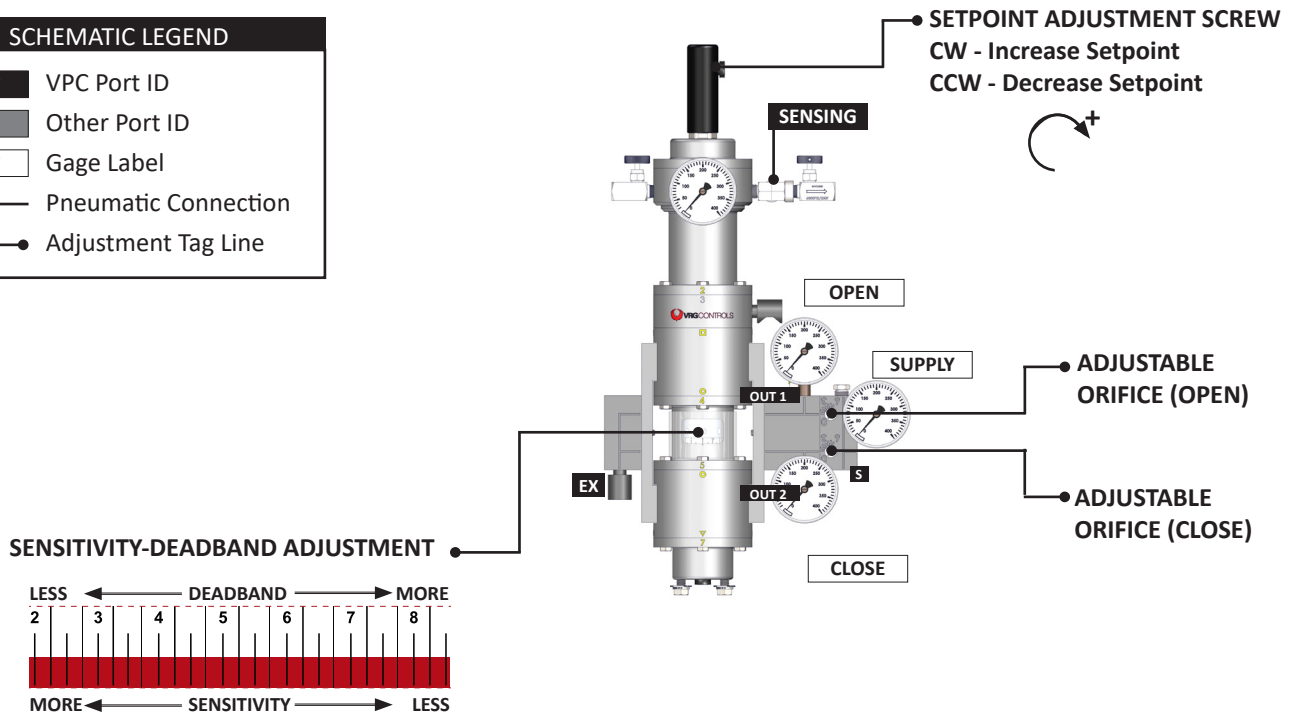



**VPC "BV" SERIES VALVE PILOT CONTROLLERS
INSTRUCTION MANUAL**

No. VPC	Actuator	Actuator Mode	Positioner	Accessory	Discharge
1A VPC-DA-BV (DA)	Piston	Double Acting	-	VMO	ATM

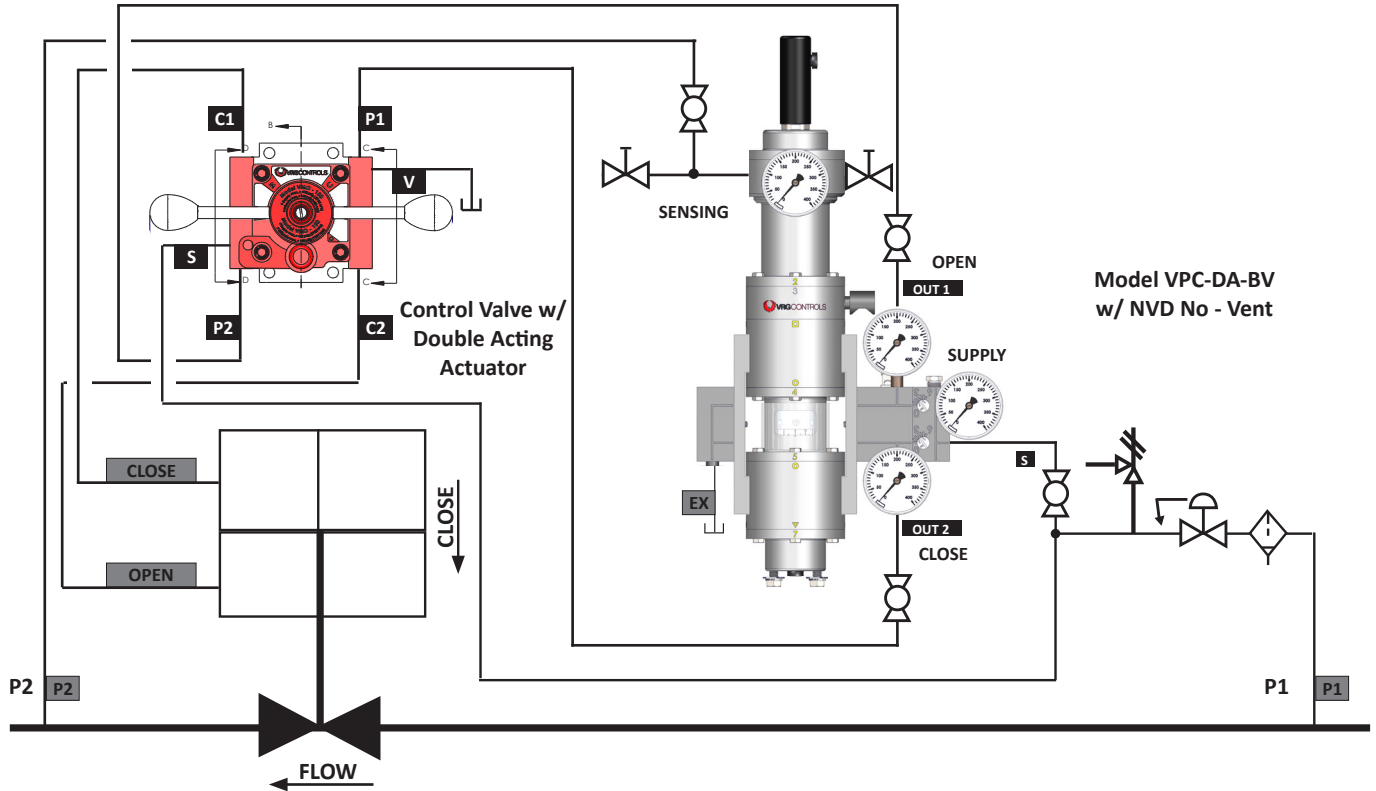

SCHEMATIC LEGEND

- TEXT** VPC Port ID
- TEXT** Other Port ID
- TEXT** Gage Label
- Pneumatic Connection
- Adjustment Tag Line

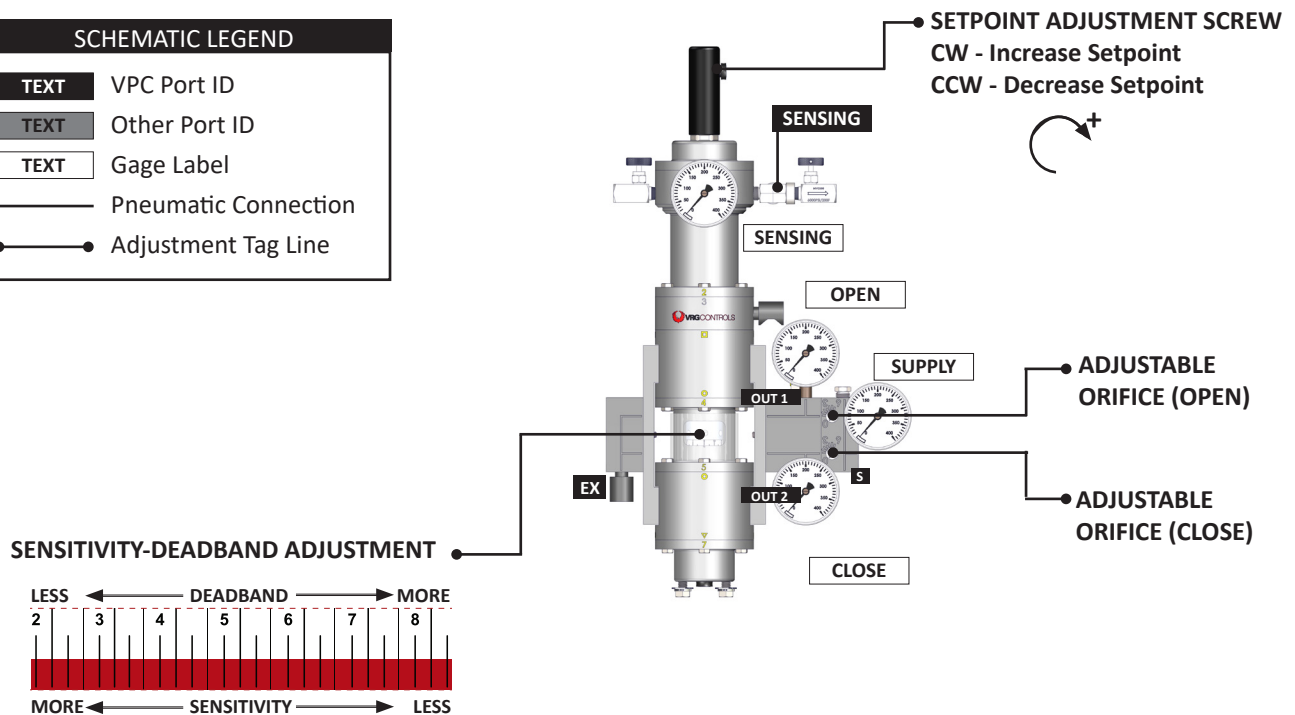

No. VPC	Actuator	Actuator Mode	Positioner	Accessory	Discharge
2 VPC-DA-BV (DA)	Piston	Double Acting	-	-	NVD-No-Vent

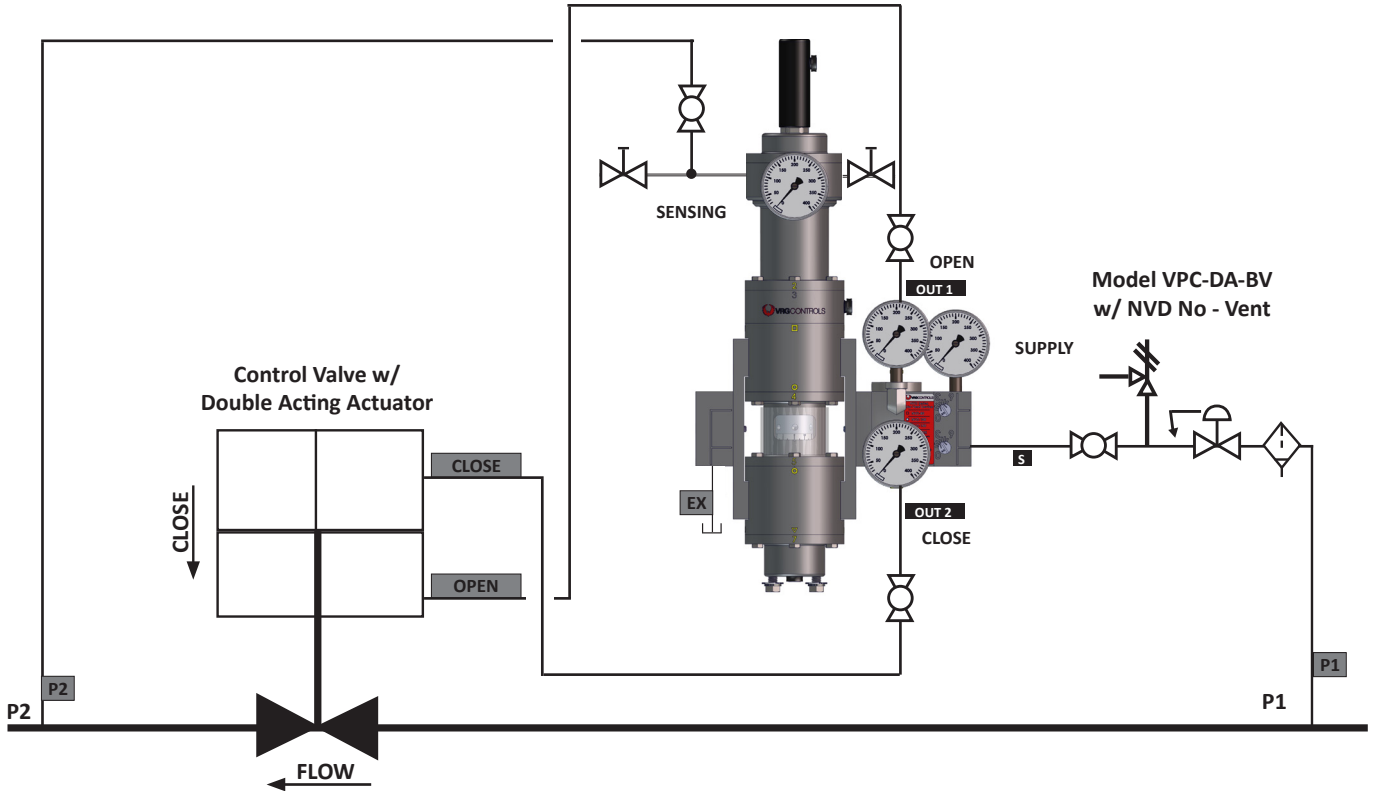

SCHEMATIC LEGEND

- TEXT** VPC Port ID
- TEXT** Other Port ID
- TEXT** Gage Label
- Pneumatic Connection
- Adjustment Tag Line

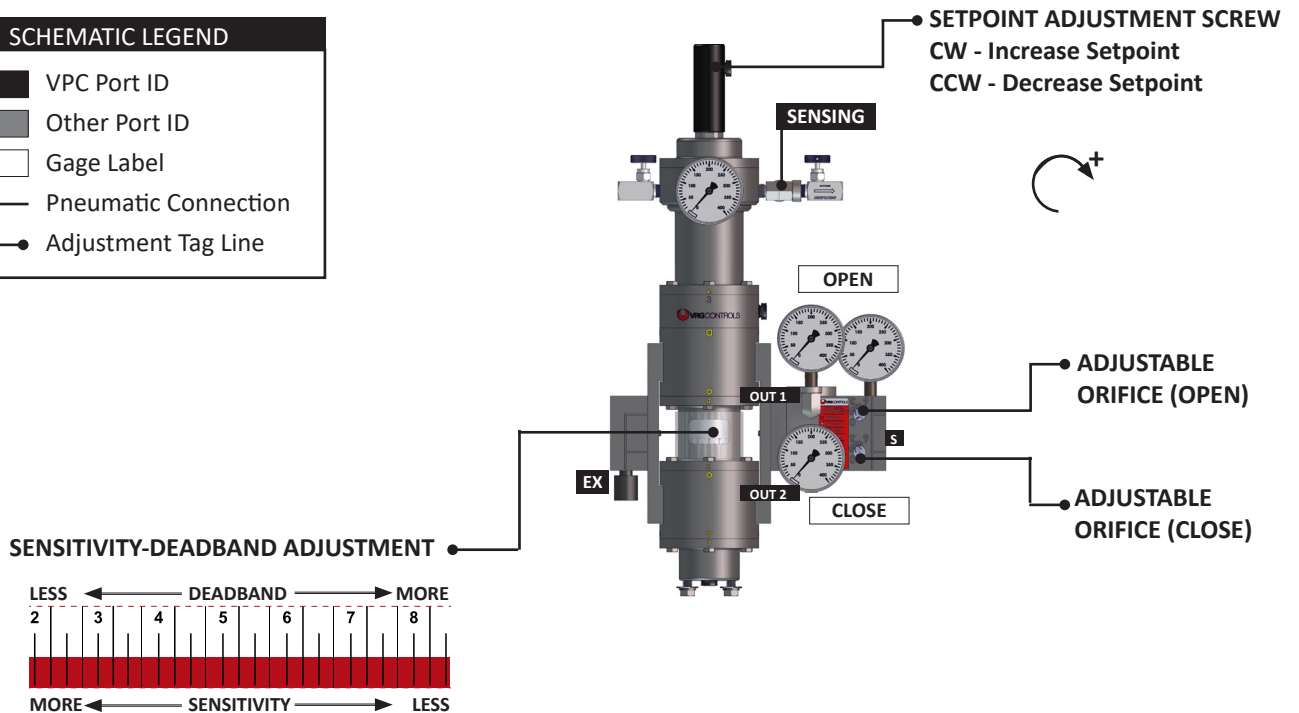

No. VPC	Actuator	Actuator Mode	Positioner	Accessory	Discharge
2A VPC-DA-BV (DA)	Piston	Double Acting	-	VMO	NVD-No-Vent

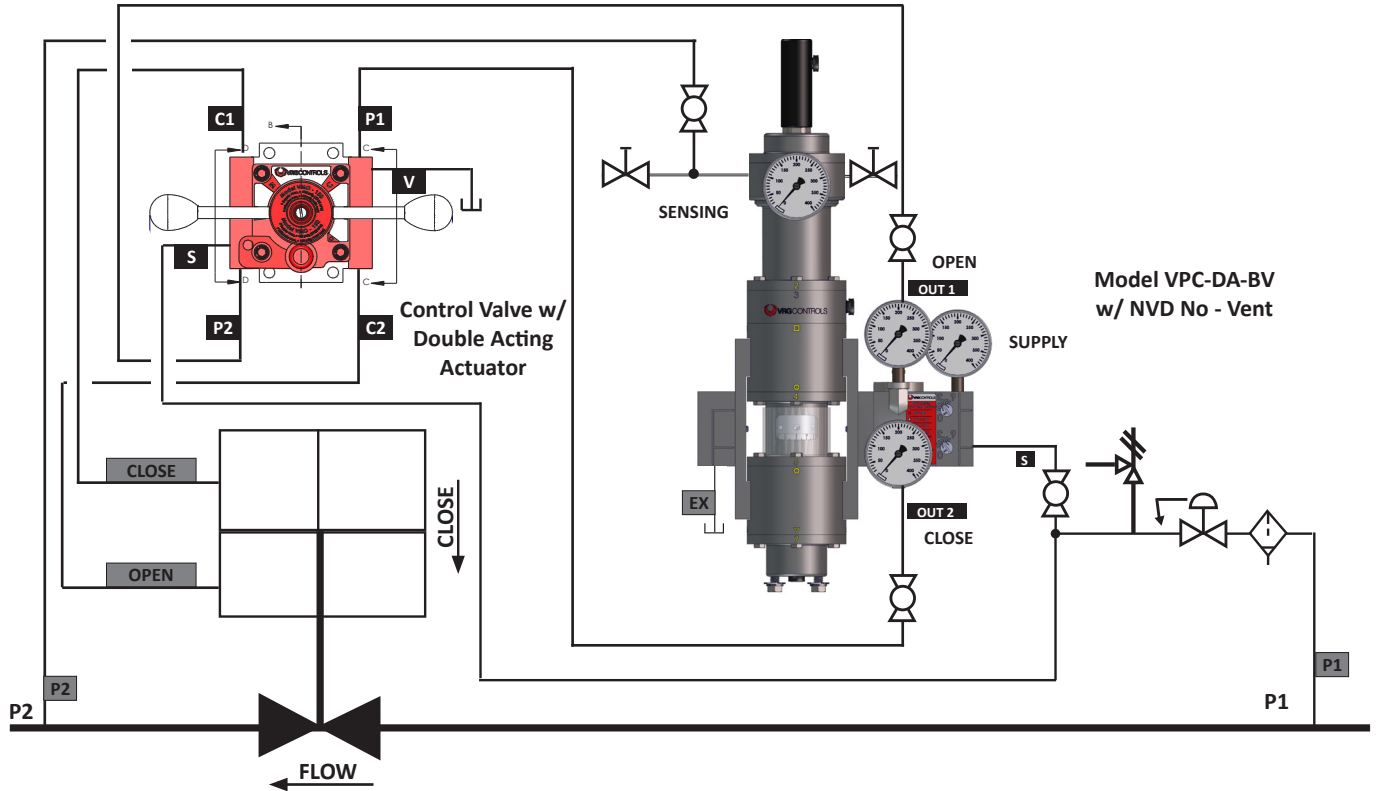

SCHEMATIC LEGEND

- TEXT VPC Port ID
- TEXT Other Port ID
- TEXT Gage Label
- Pneumatic Connection
- Adjustment Tag Line

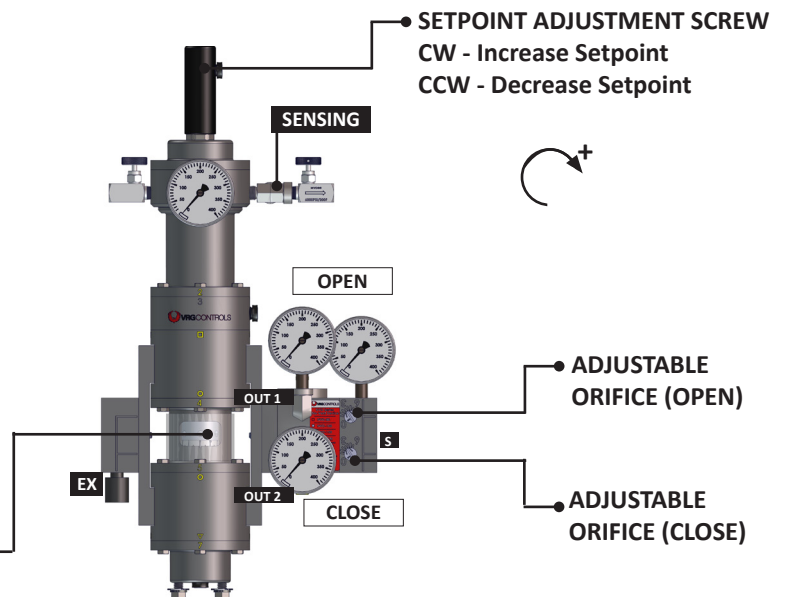
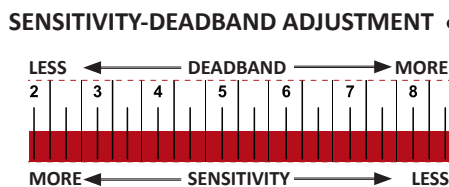

No. VPC	Actuator	Actuator Mode	Positioner	Accessory	Discharge
3 VPC-SA-BV (DIR)	Spring Piston	Spring Open	-	-	ATM

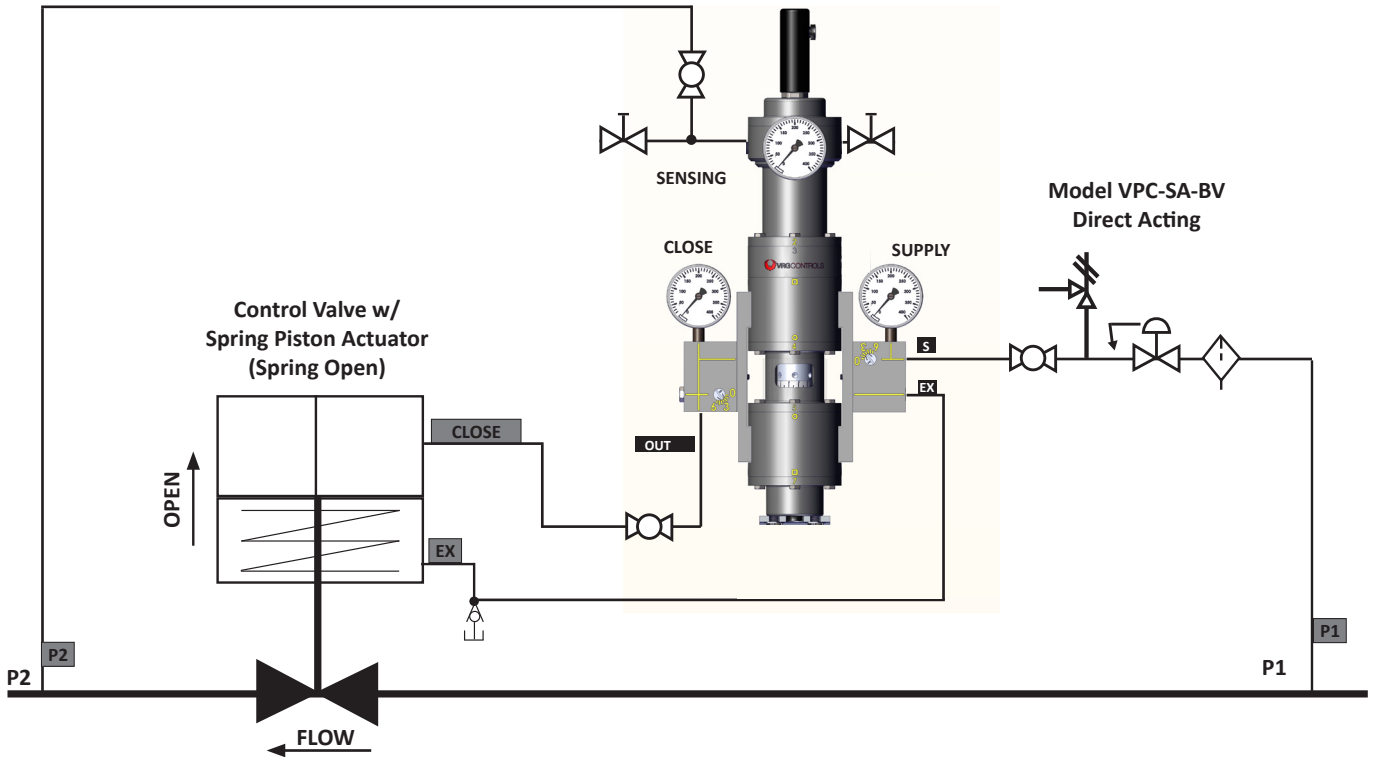

SCHEMATIC LEGEND

- TEXT** VPC Port ID
- TEXT** Other Port ID
- TEXT** Gage Label
- Pneumatic Connection
- Adjustment Tag Line

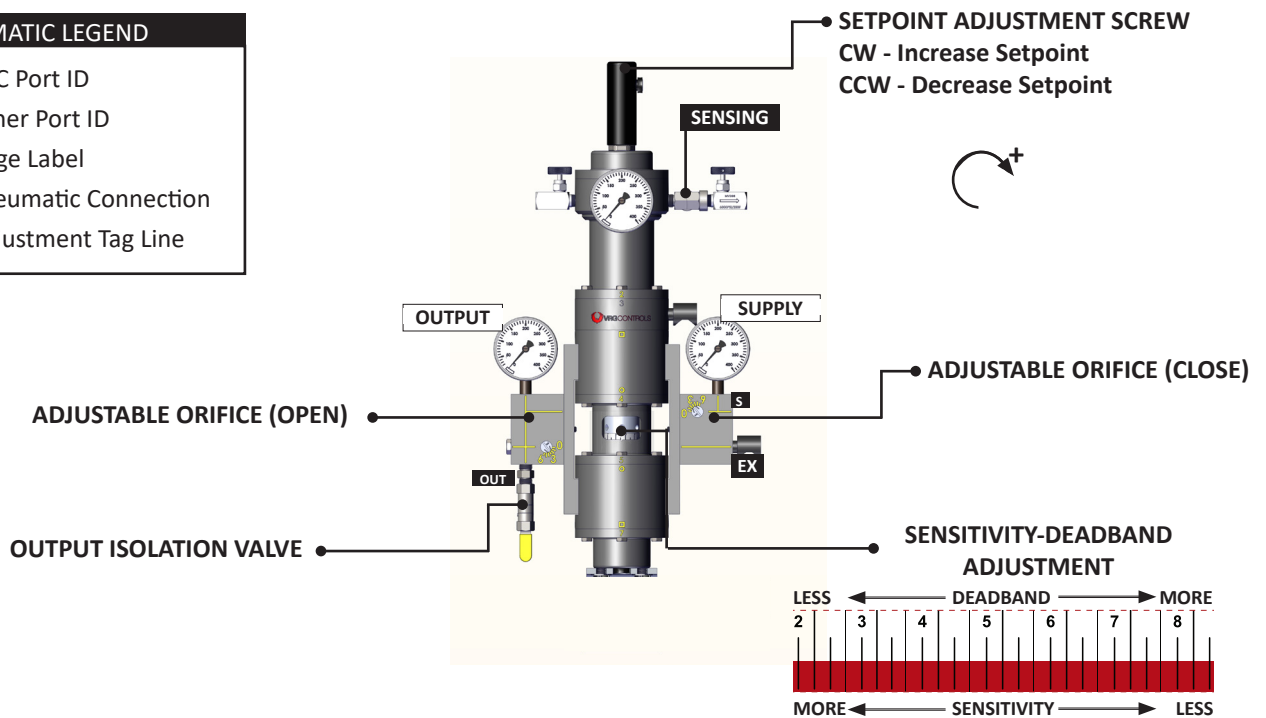

No. VPC	Actuator	Actuator Mode	Positioner	Accessory	Discharge
3A VPC-SA-BV (DIR)	Spring Piston	Spring Open	-	VMO	ATM

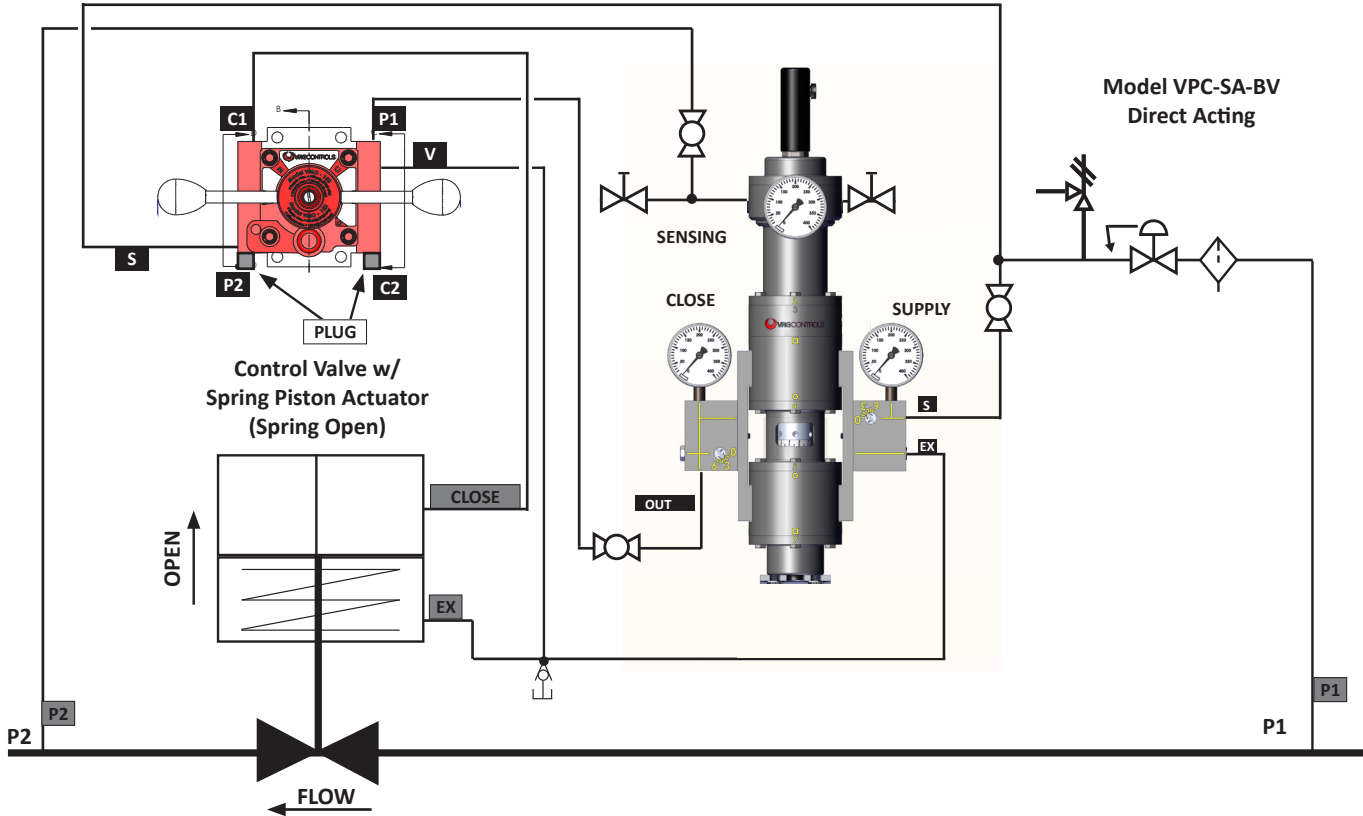

SCHEMATIC LEGEND

- TEXT VPC Port ID
- TEXT Other Port ID
- TEXT Gage Label
- Pneumatic Connection
- Adjustment Tag Line

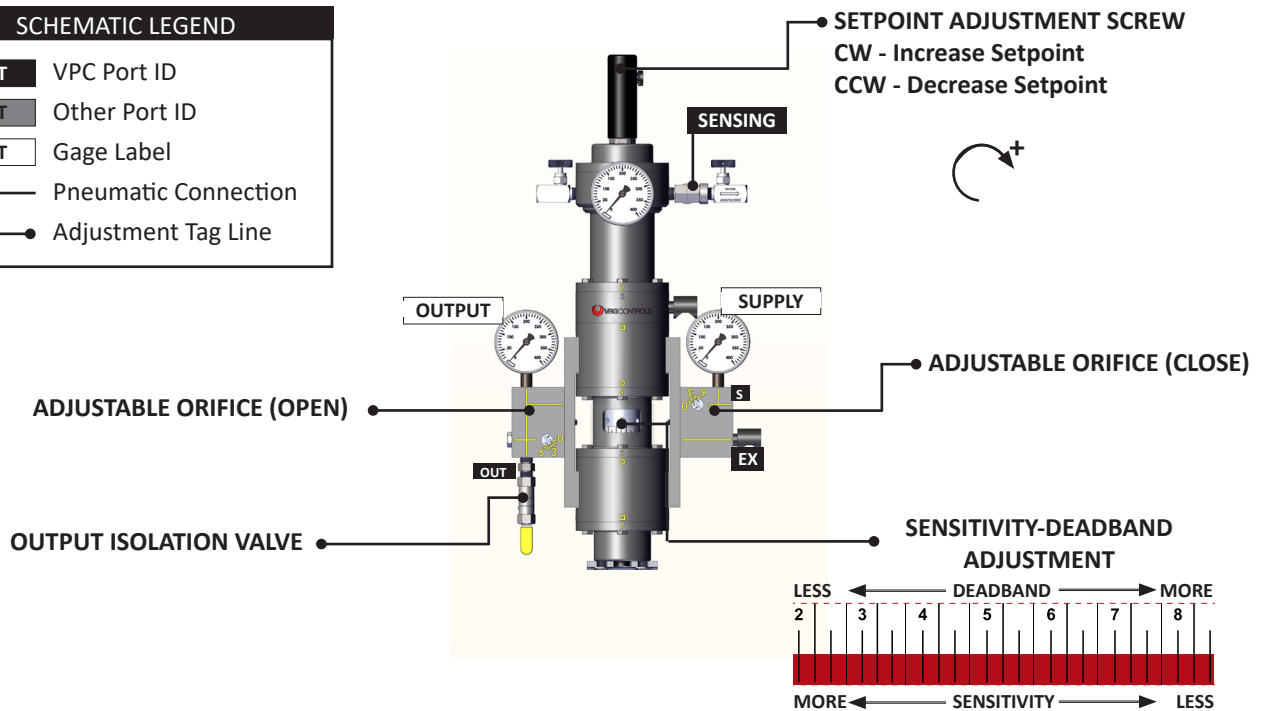

No. VPC	Actuator	Actuator Mode	Positioner	Accessory	Discharge
4 VPC-SA-BV (REV)	Spring Piston	Spring Closed	-	-	ATM

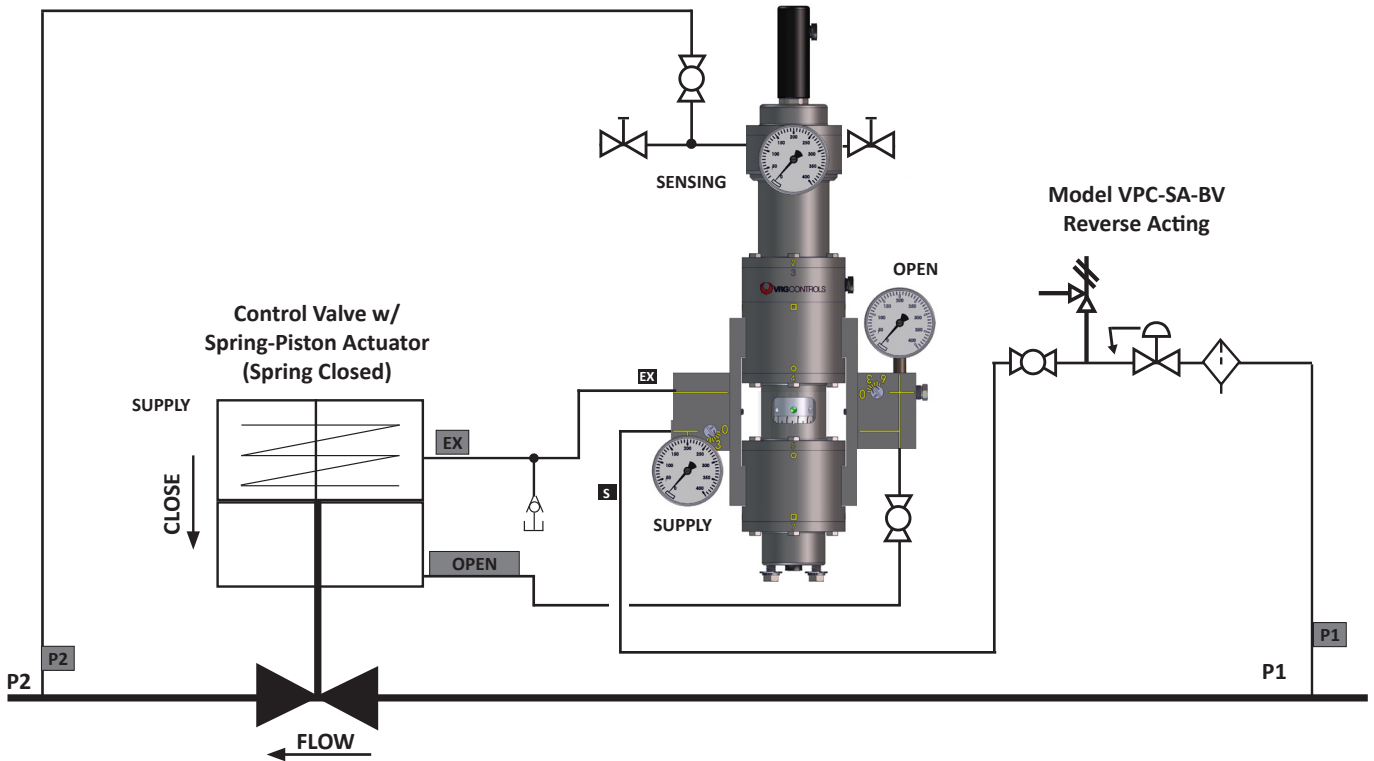

SCHEMATIC LEGEND

- TEXT** VPC Port ID
- TEXT** Other Port ID
- TEXT** Gage Label
- Pneumatic Connection
- Adjustment Tag Line

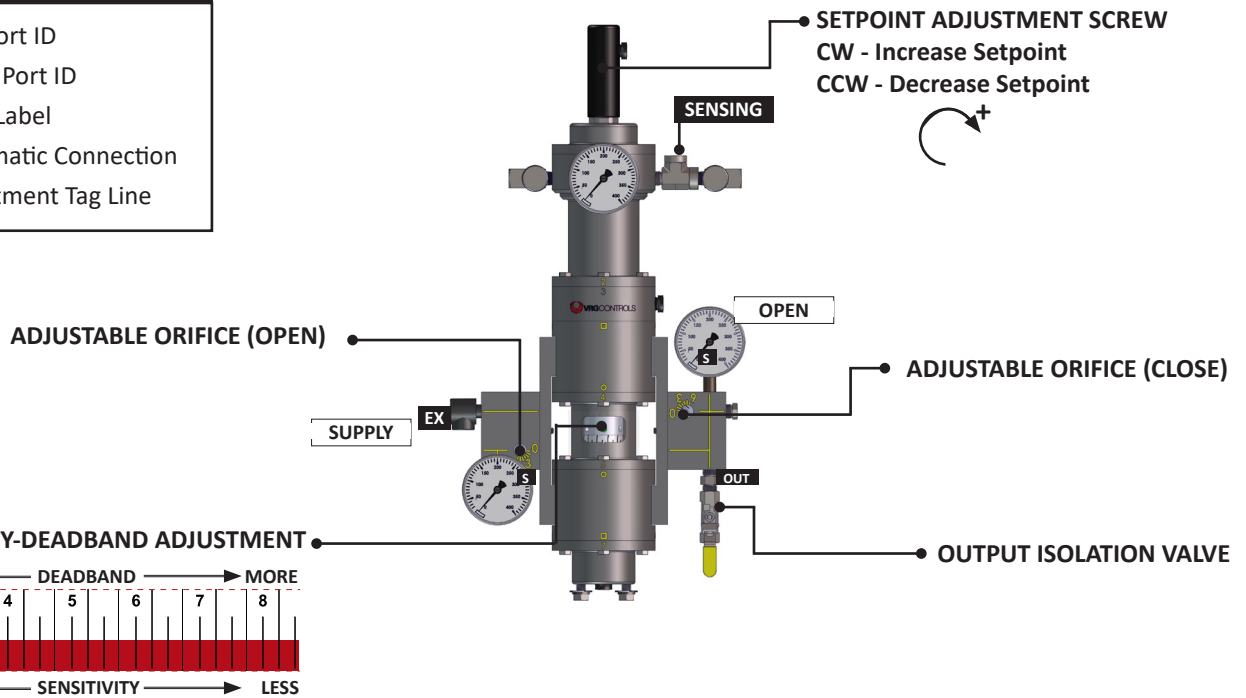

No. VPC	Actuator	Actuator Mode	Positioner	Accessory	Discharge
4A VPC-SA-BV (REV)	Spring Piston	Spring Closed	-	VMO	ATM

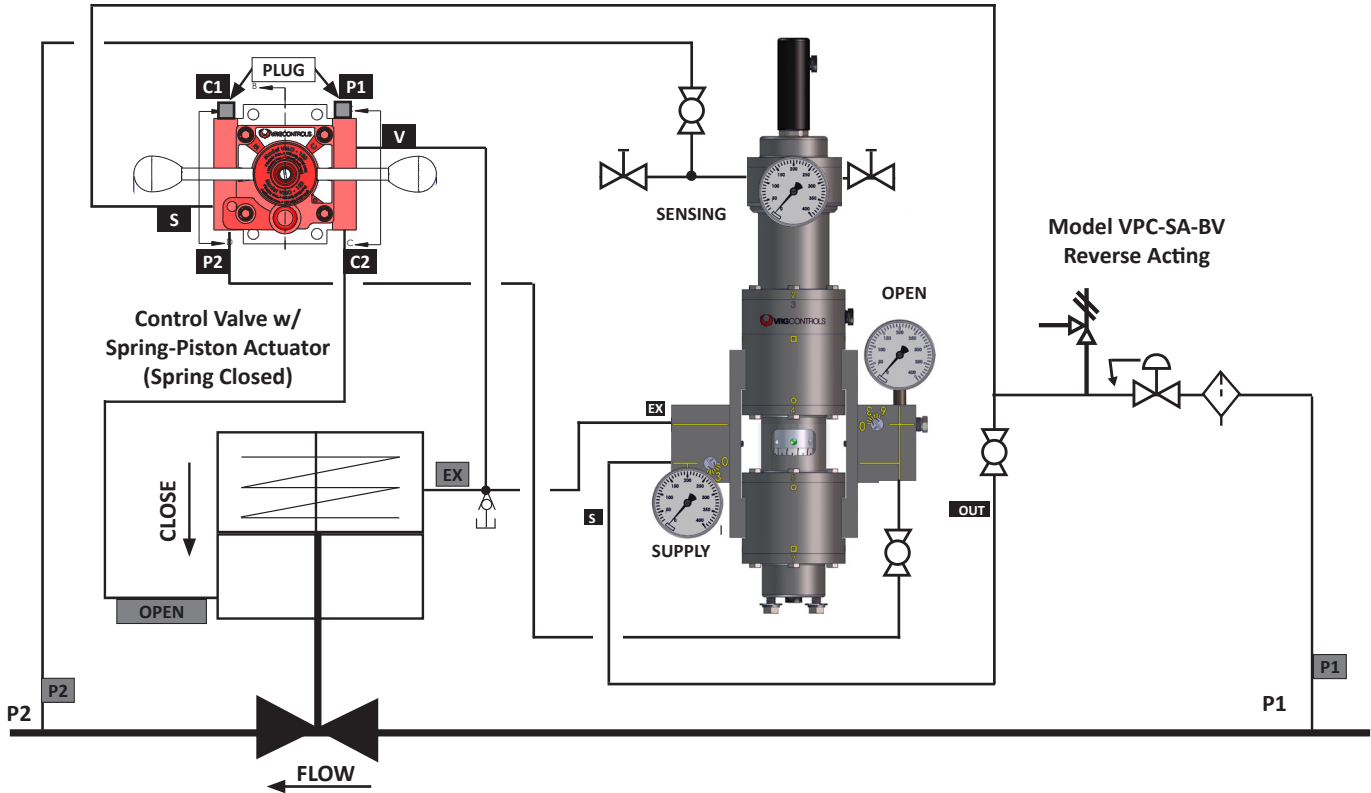

SCHEMATIC LEGEND

- TEXT VPC Port ID
- TEXT Other Port ID
- TEXT Gage Label
- Pneumatic Connection
- Adjustment Tag Line

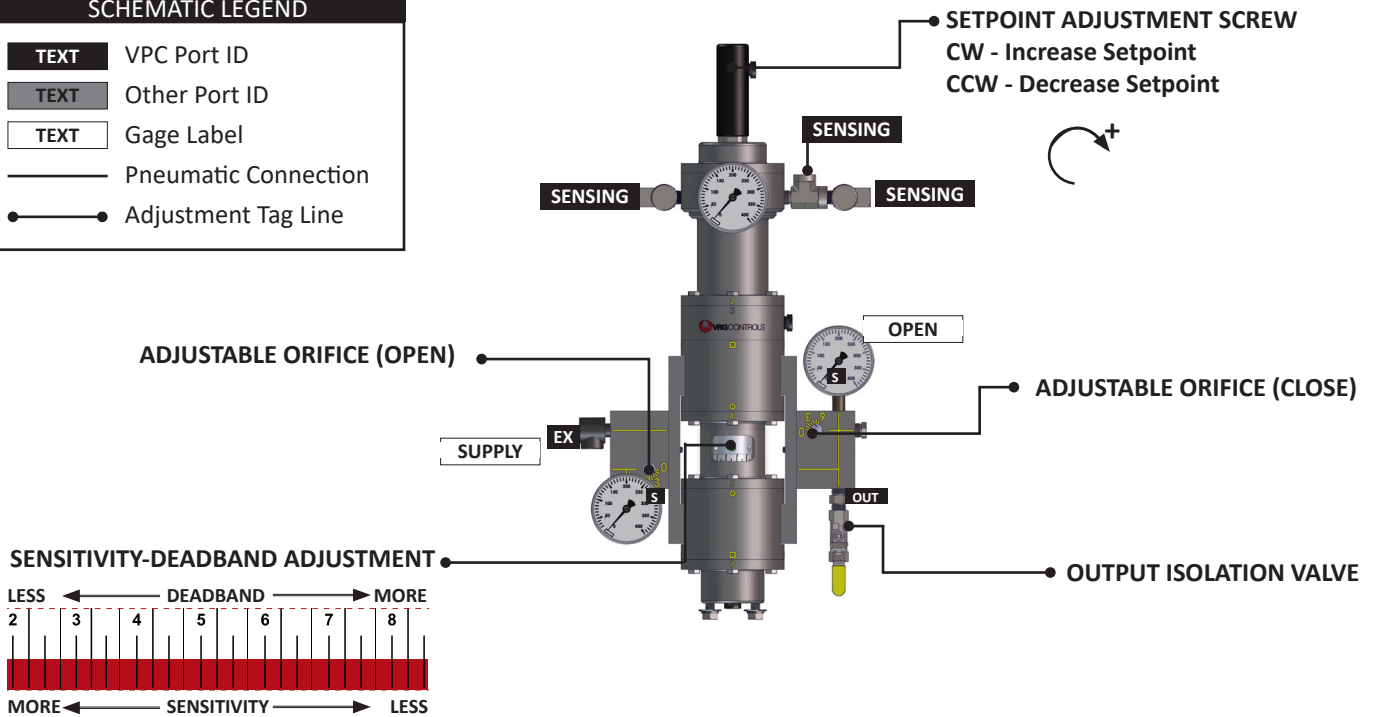

No. VPC	Actuator	Actuator Mode	Positioner	Accessory	Discharge
5 VPC-SA-BV (REV)	Spring Piston	Spring Closed	-	Quick Exhaust	ATM

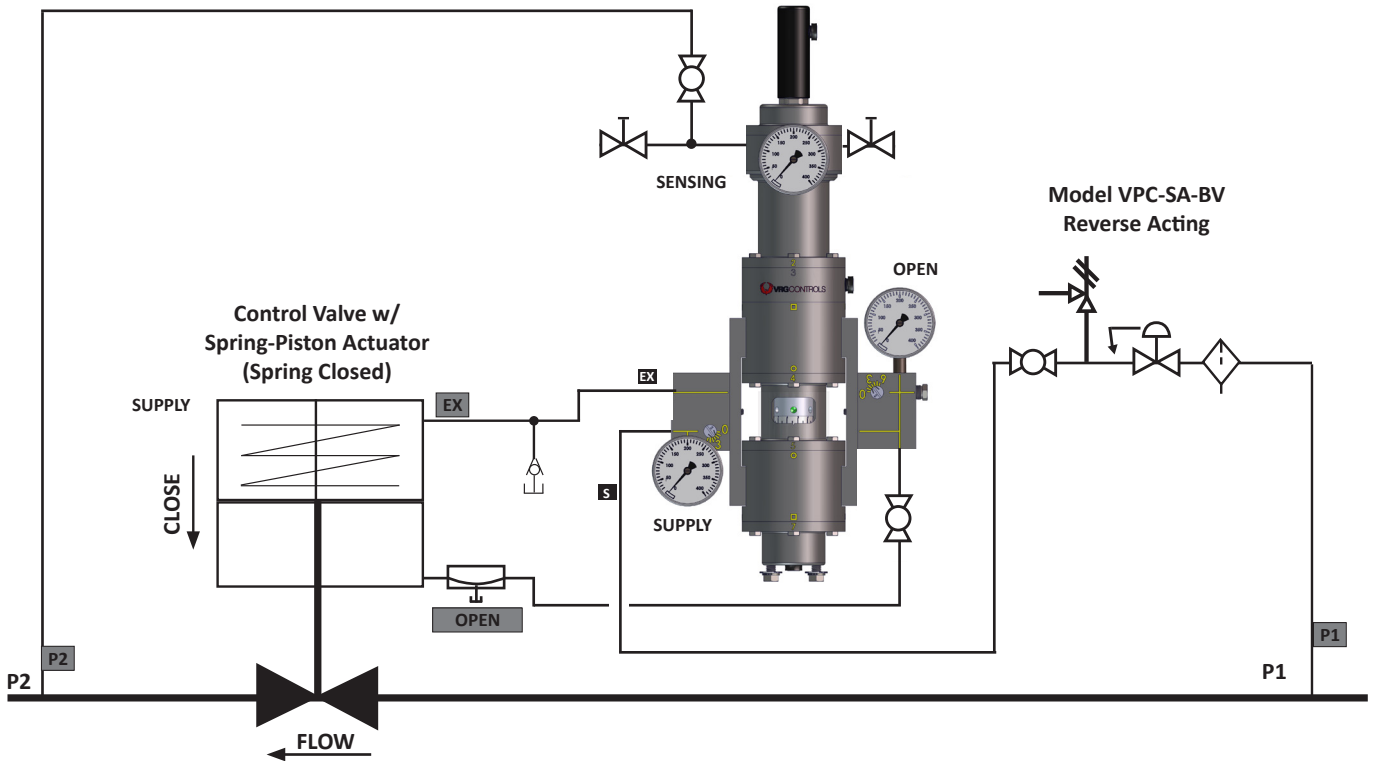

SCHEMATIC LEGEND

- TEXT VPC Port ID
- TEXT Other Port ID
- TEXT Gage Label
- Pneumatic Connection
- Adjustment Tag Line

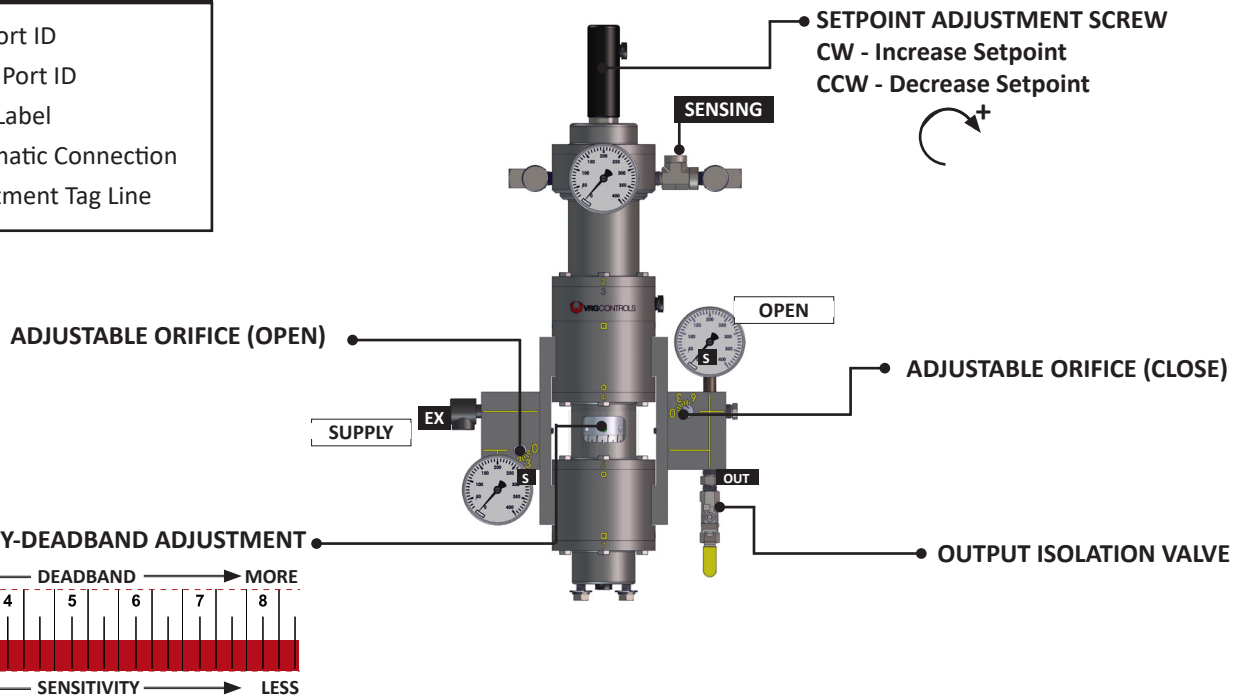

No. VPC	Actuator	Actuator Mode	Positioner	Accessory	Discharge
5A VPC-SA-BV (REV)	Spring Piston	Spring Closed	-	VMO + Quick Exhaust	ATM

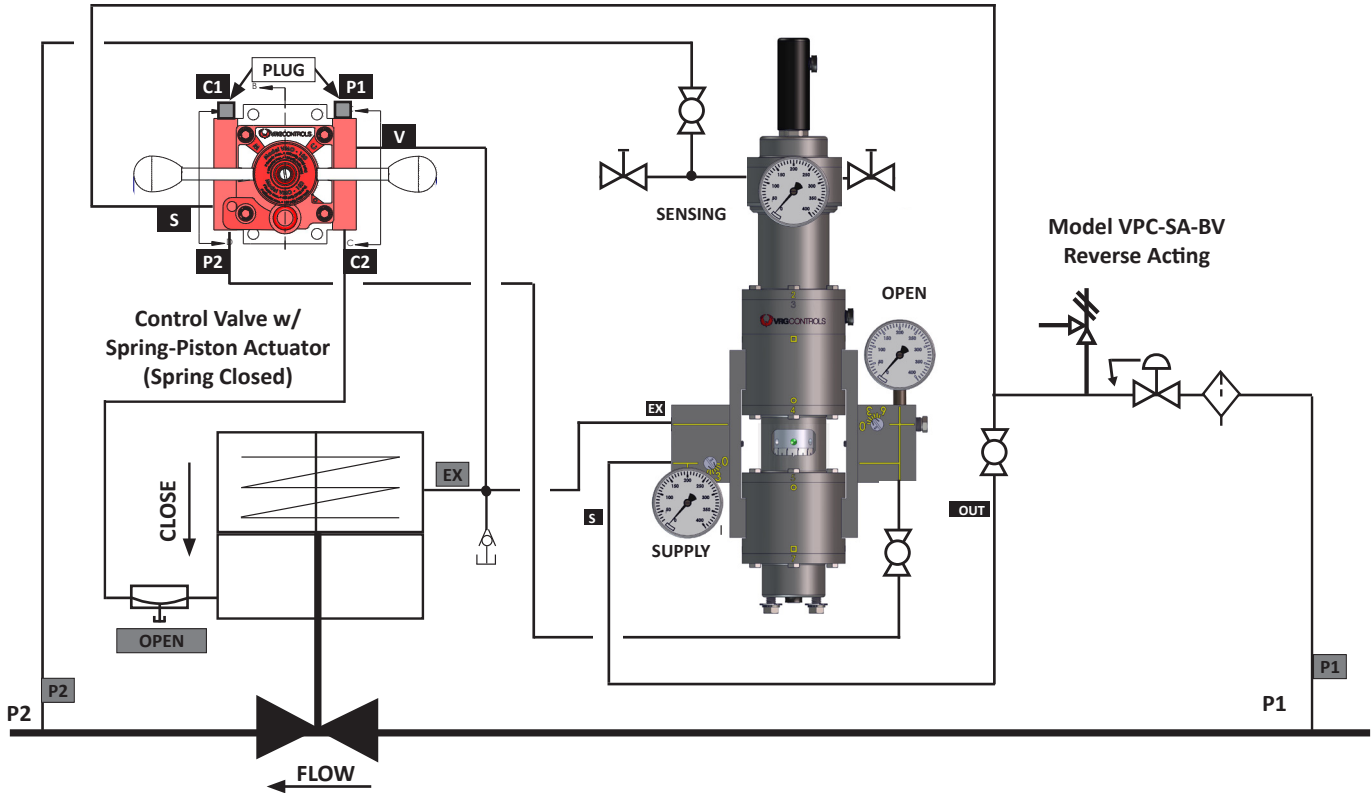

SCHEMATIC LEGEND

- TEXT** VPC Port ID
- TEXT** Other Port ID
- TEXT** Gage Label
- Pneumatic Connection
- Adjustment Tag Line

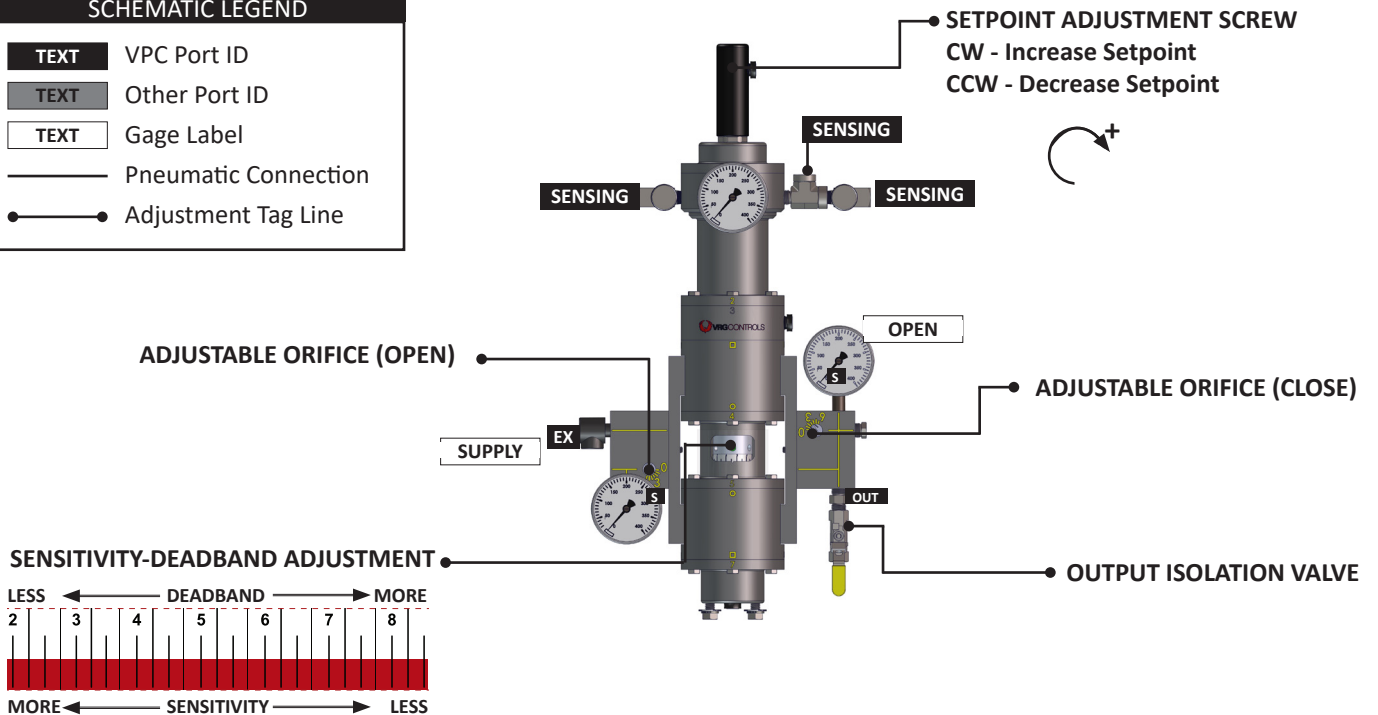

No. VPC	Actuator	Actuator Mode	Positioner	Accessory	Discharge
6 VPC-SA-BV-ID (DIR)	Spring Piston	Spring Open	Close INCR	-	ATM

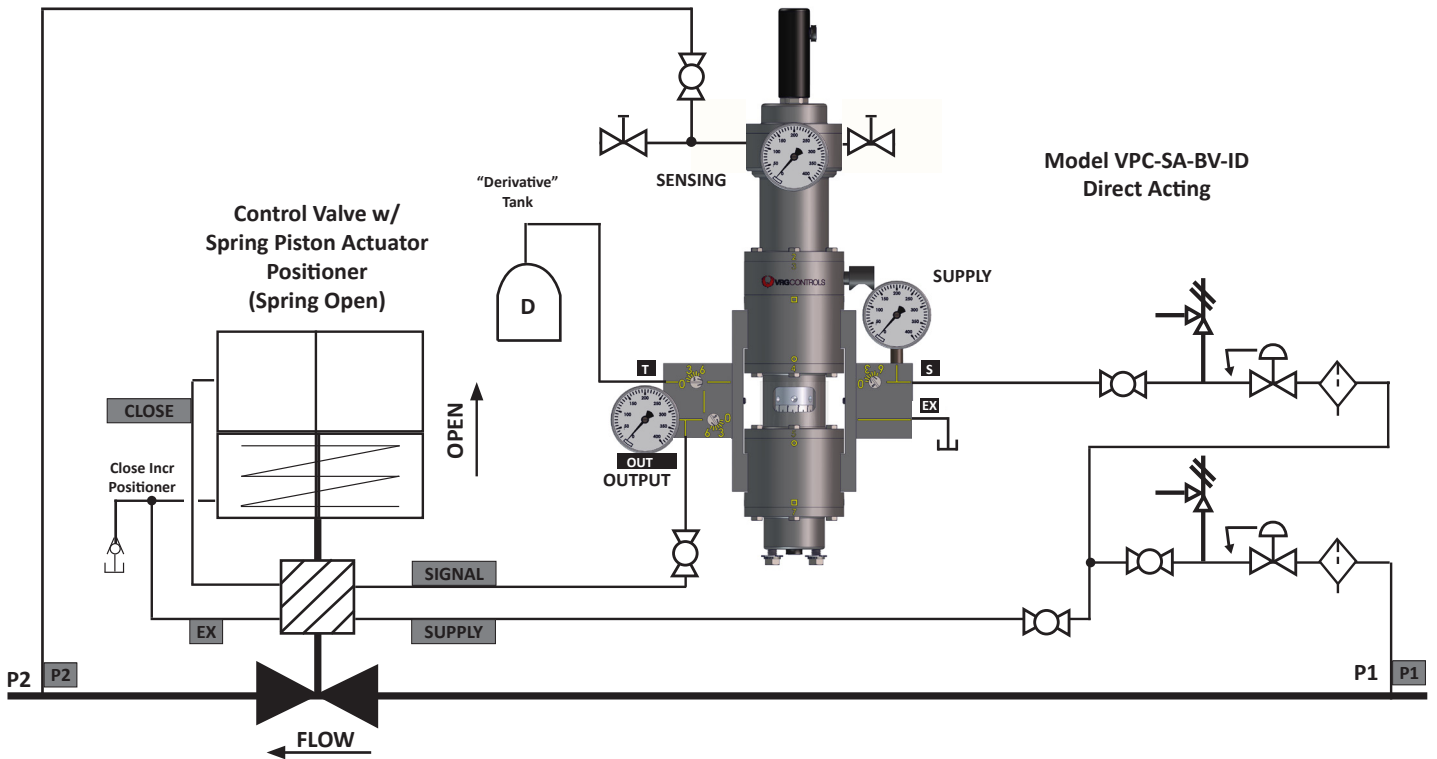

SCHEMATIC LEGEND

- TEXT** VPC Port ID
- TEXT** Other Port ID
- TEXT** Gage Label
- Pneumatic Connection
- Adjustment Tag Line

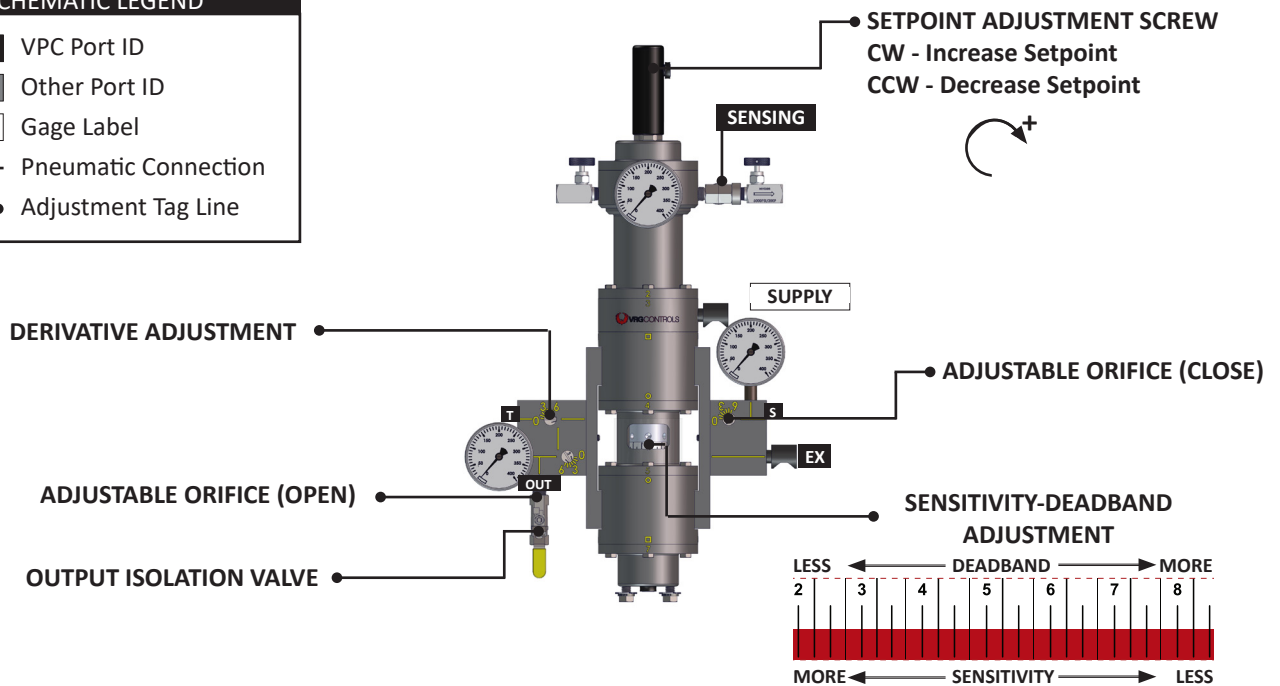

No. VPC	Actuator	Actuator Mode	Positioner	Accessory	Discharge
6A VPC-SA-BV-ID (DIR)	Spring Piston	Spring Open	Close INCR	VMO	ATM

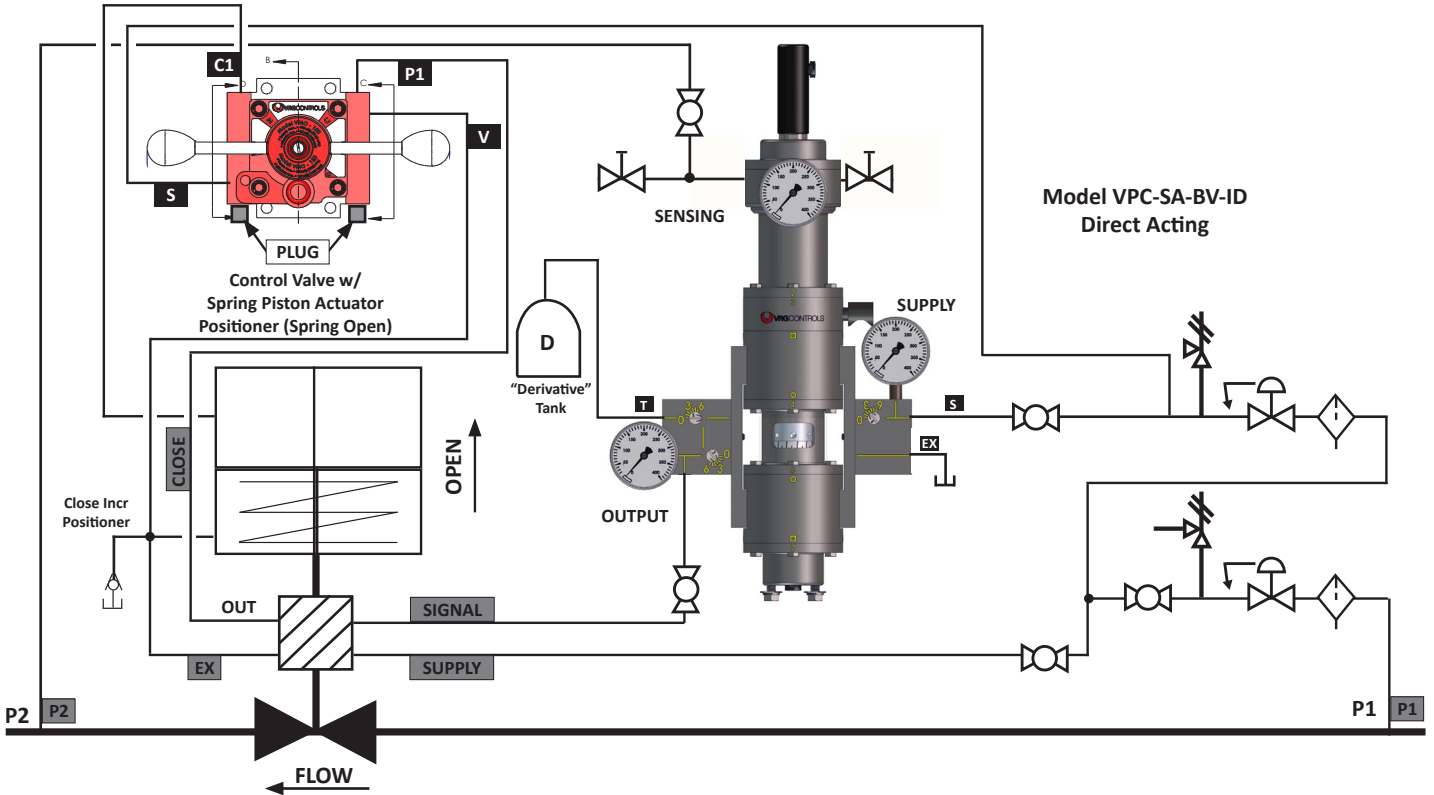

SCHEMATIC LEGEND

- TEXT** VPC Port ID
- TEXT** Other Port ID
- TEXT** Gage Label
- Pneumatic Connection
- Adjustment Tag Line

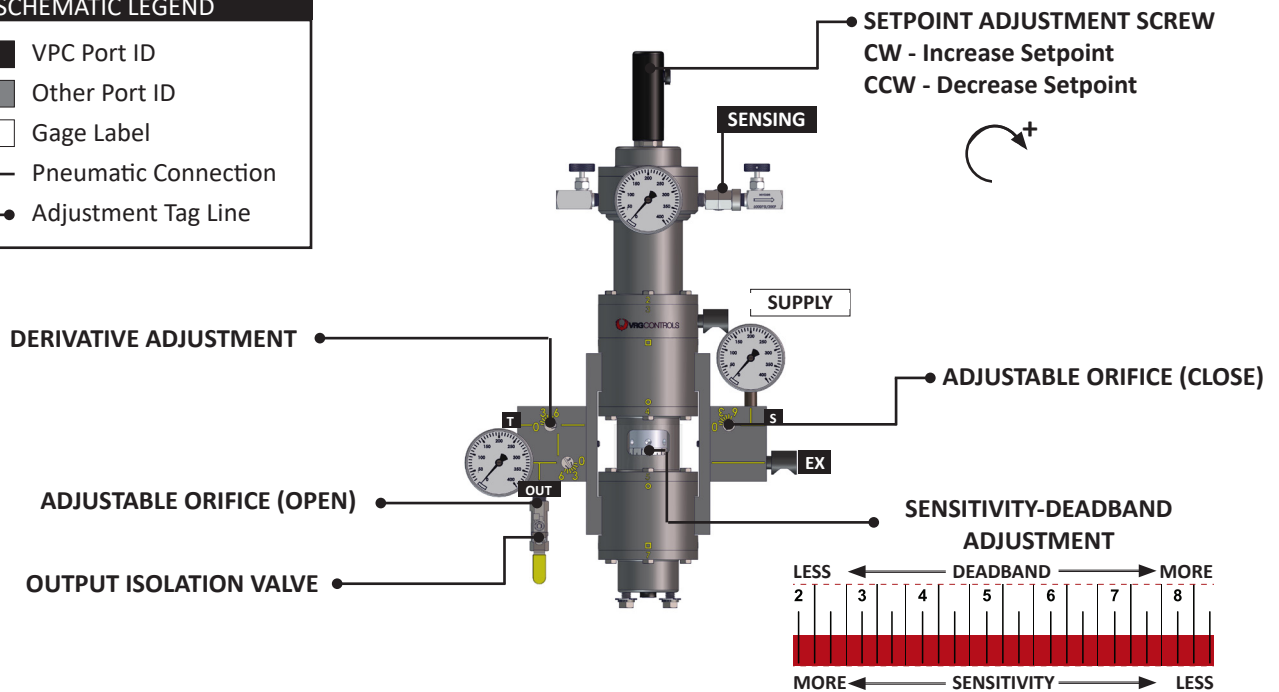

No. VPC	Actuator	Actuator Mode	Positioner	Accessory	Discharge
7 VPC-SA-BV-ID (REV)	Spring Piston	Spring Close	Open INCR	-	ATM

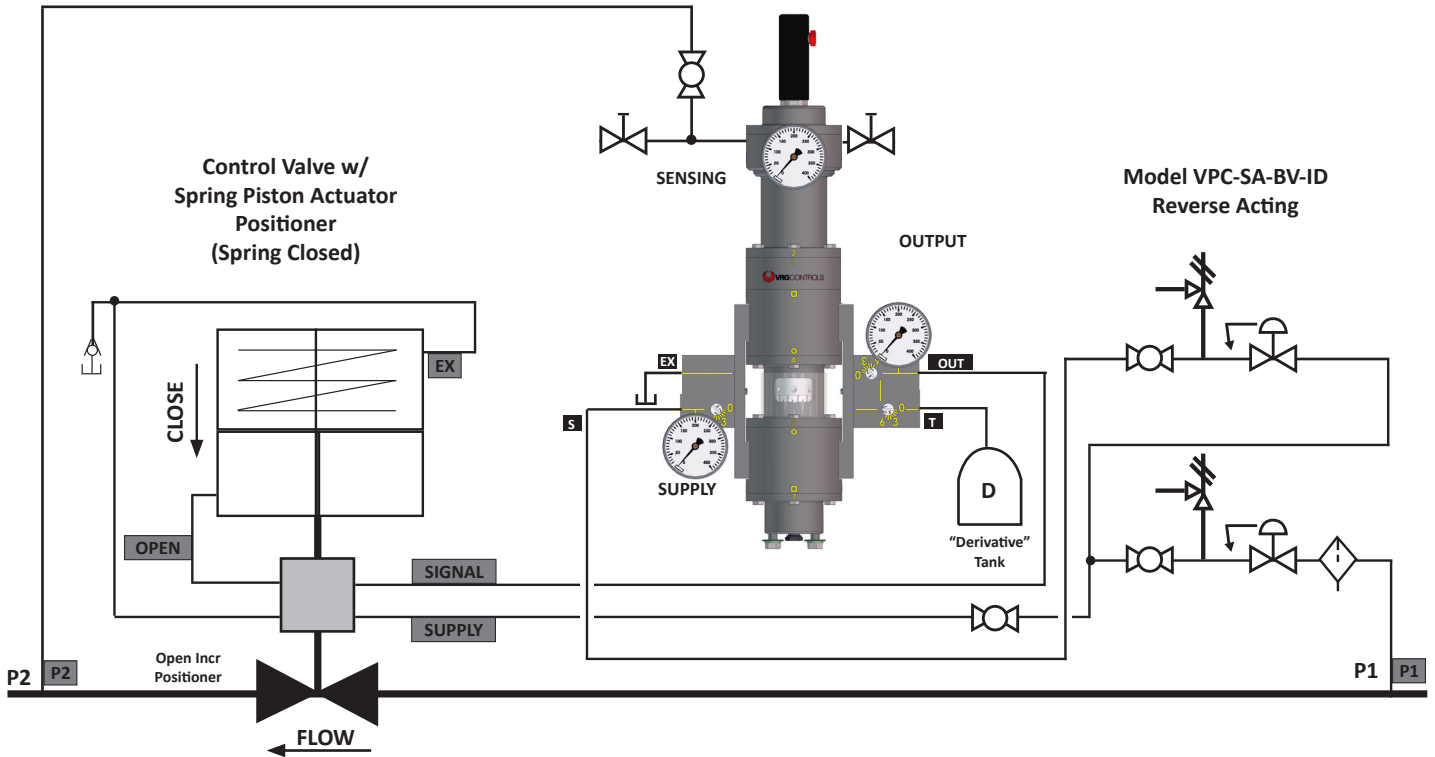

SCHEMATIC LEGEND

- TEXT** VPC Port ID
- TEXT** Other Port ID
- TEXT** Gage Label
- Pneumatic Connection
- Adjustment Tag Line

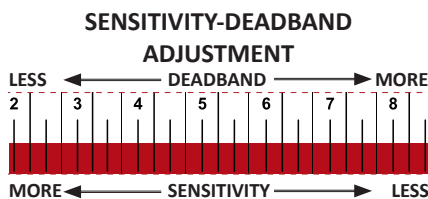
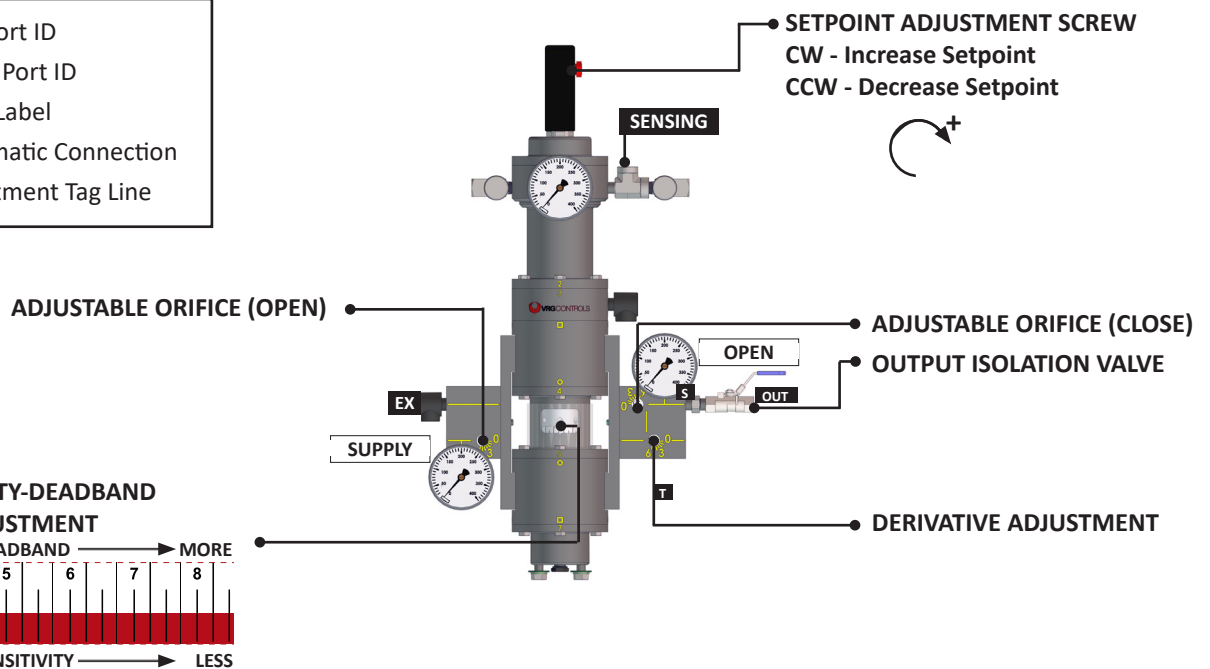

No. VPC	Actuator	Actuator Mode	Positioner	Accessory	Discharge
7A VPC-SA-BV-ID (REV)	Spring Piston	Spring Close	Open INCR	VMO	ATM

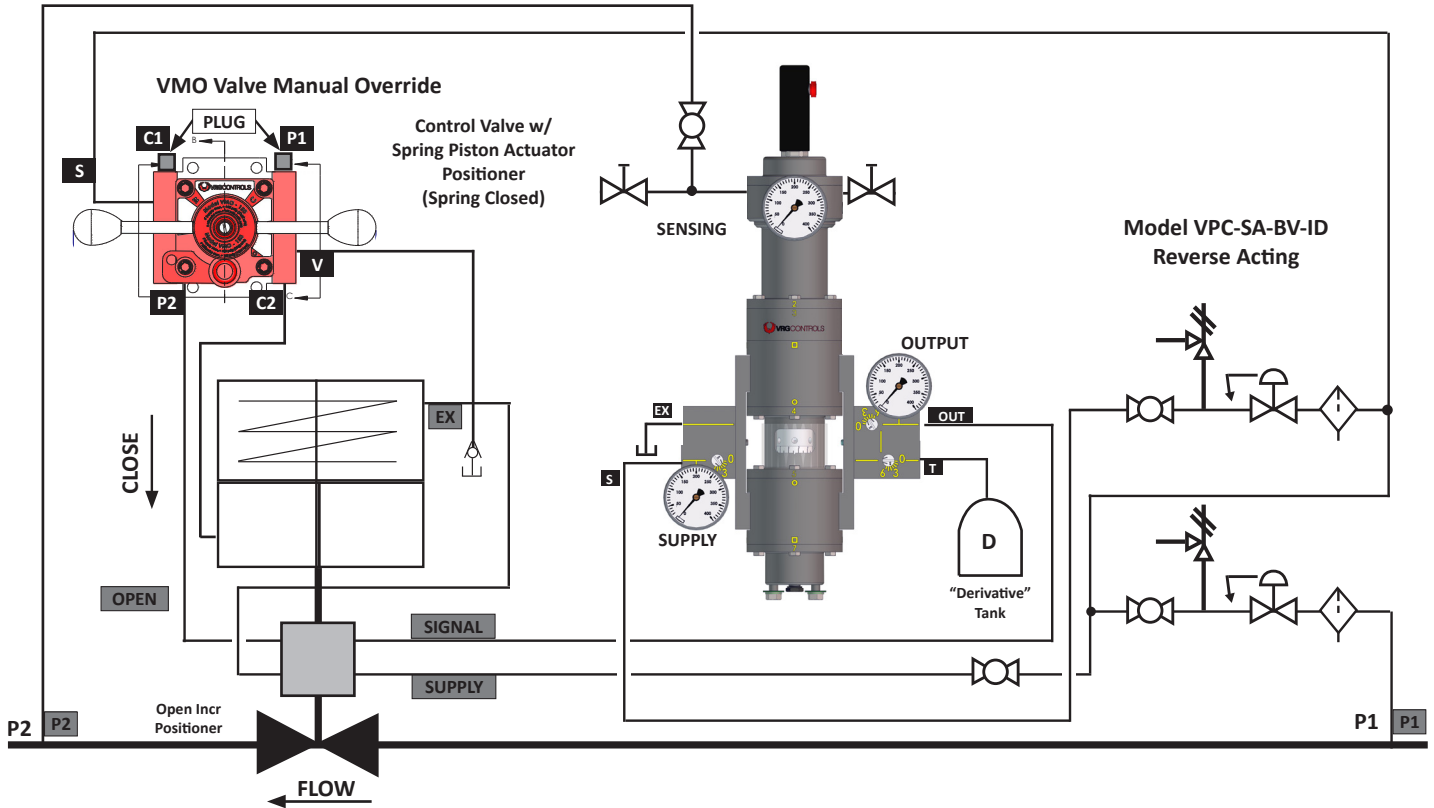

SCHEMATIC LEGEND

- TEXT VPC Port ID
- TEXT Other Port ID
- TEXT Gage Label
- Pneumatic Connection
- Adjustment Tag Line

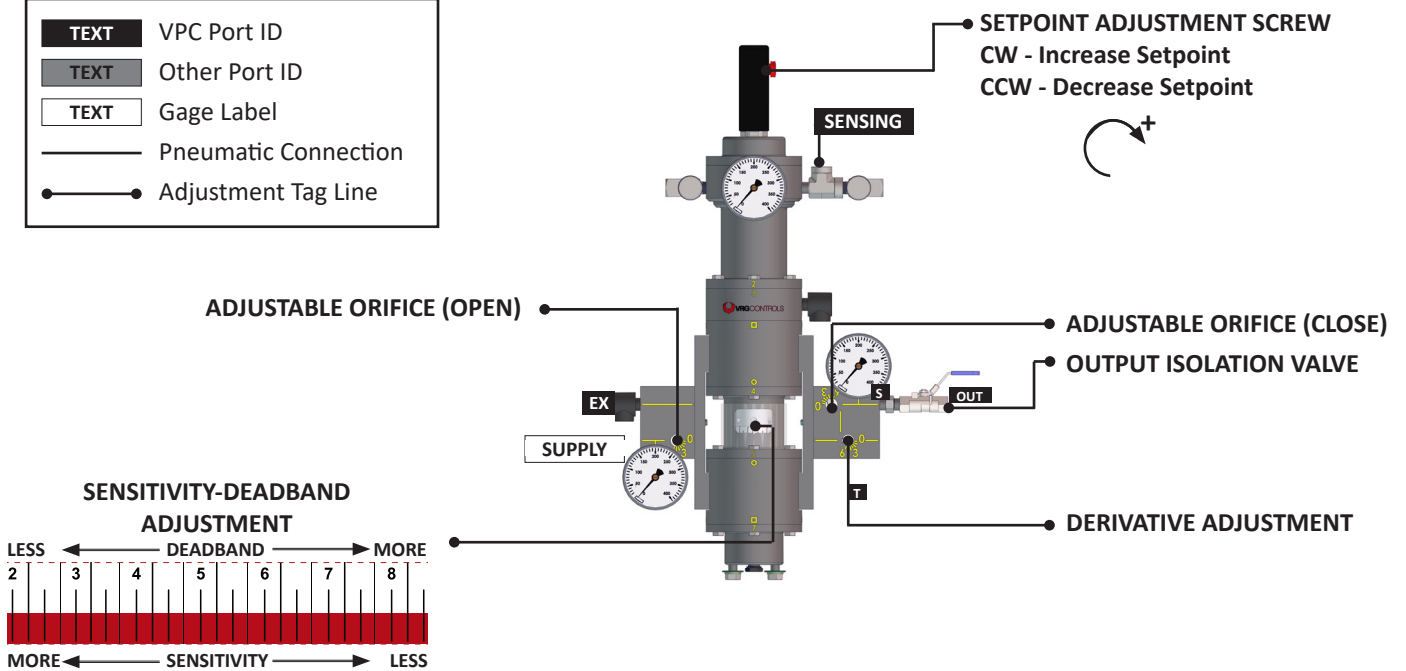

No. VPC	Actuator	Actuator Mode	Positioner	Accessory	Discharge
8 VPC-SA-BV-ID (DIR)	Spring Piston	Spring Open	-	BOOSTER	ATM

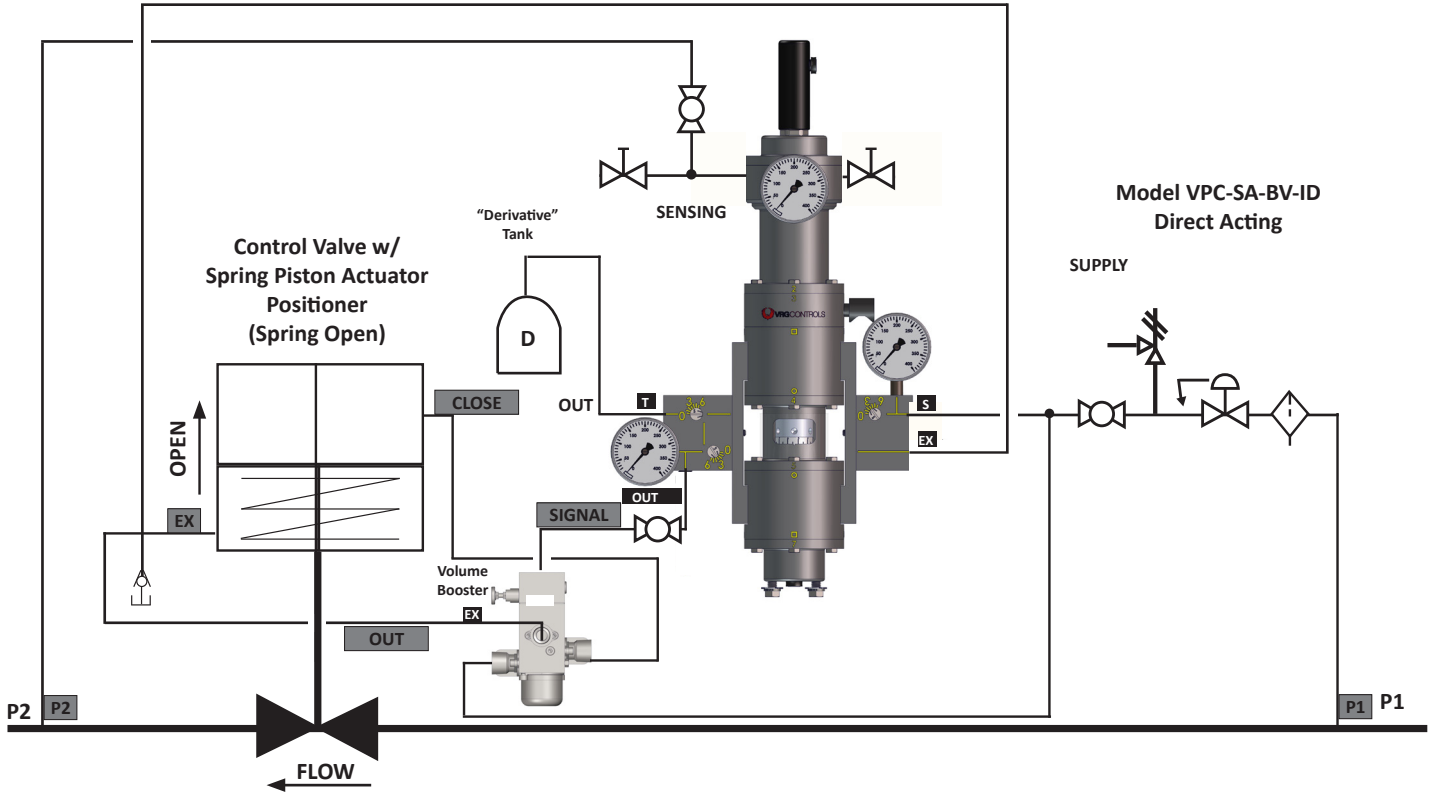

SCHEMATIC LEGEND

- TEXT VPC Port ID
- TEXT Other Port ID
- TEXT Gage Label
- Pneumatic Connection
- Adjustment Tag Line

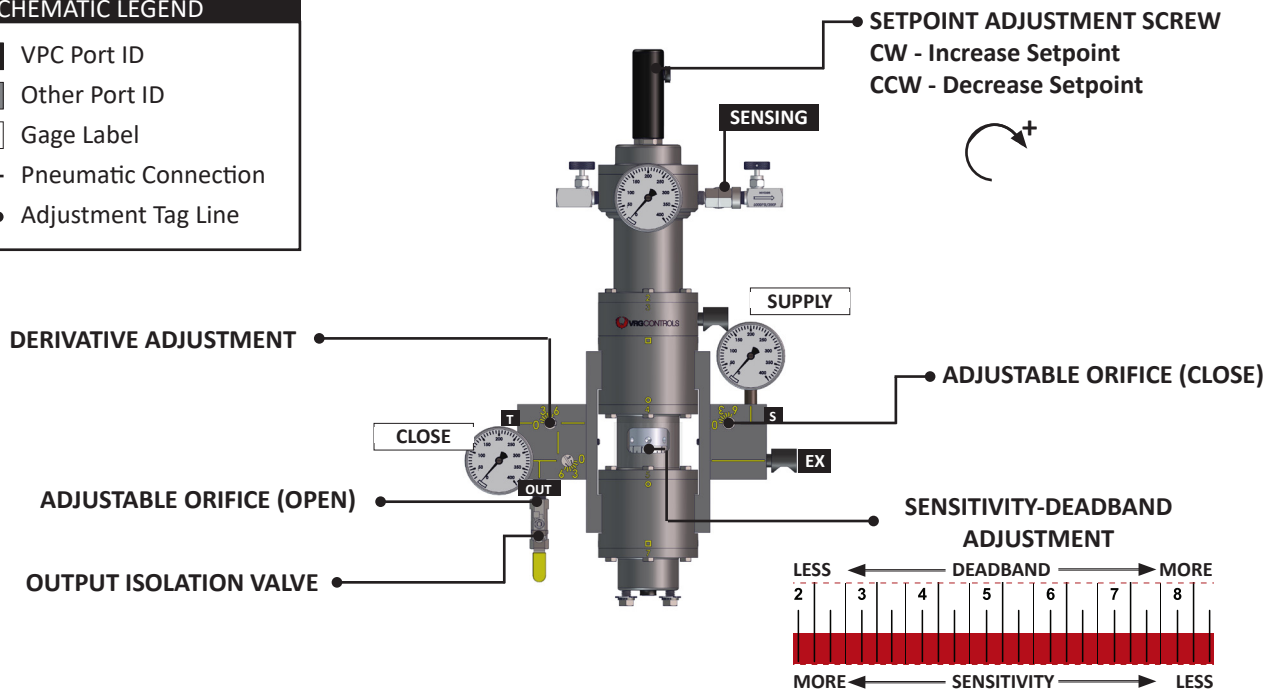

No. VPC	Actuator	Actuator Mode	Positioner	Accessory	Discharge
8A VPC-SA-BV-ID (DIR)	Spring Piston	Spring Open	-	BOOSTER +VMO	ATM

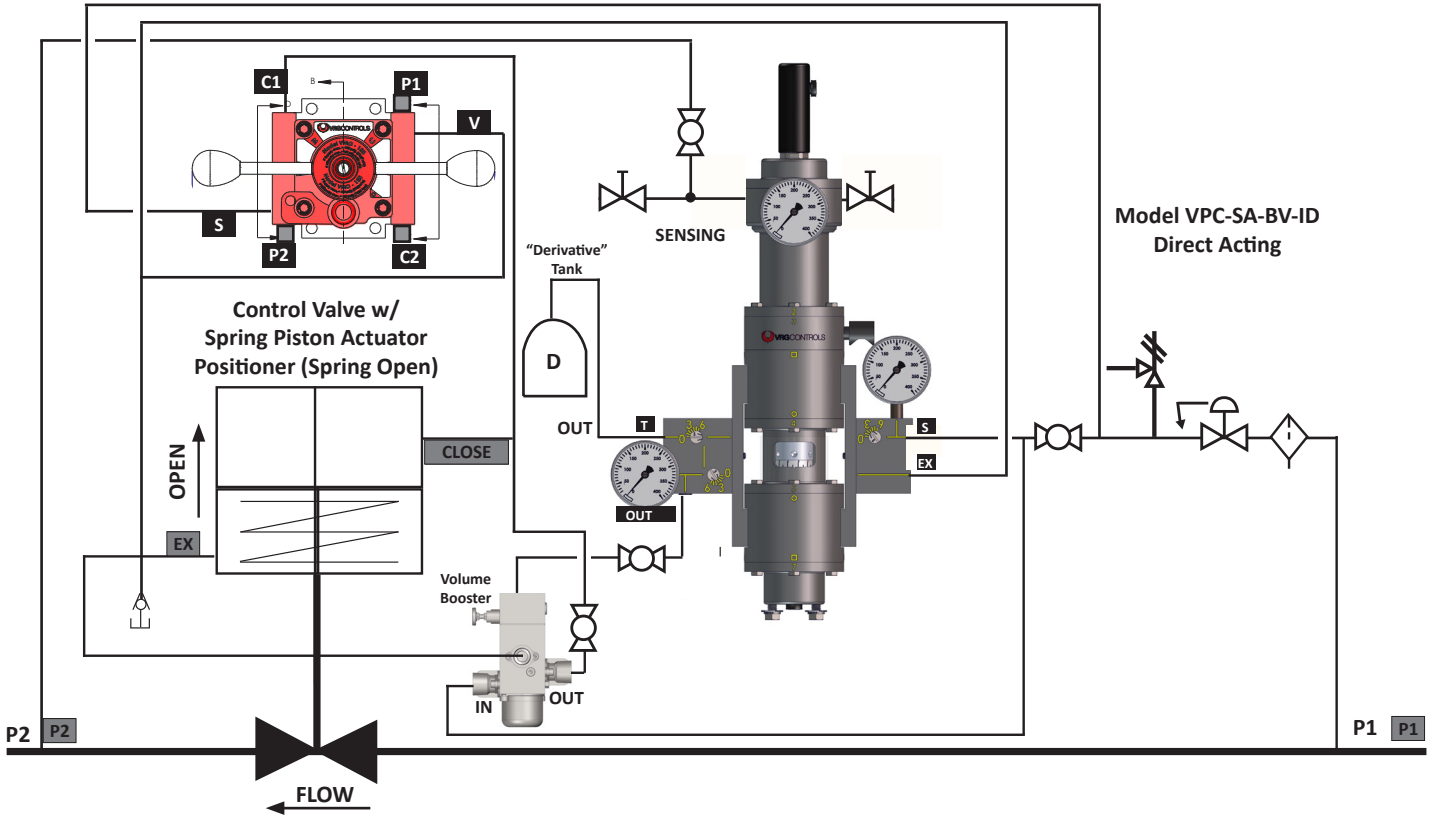

SCHEMATIC LEGEND

- TEXT VPC Port ID
- TEXT Other Port ID
- TEXT Gage Label
- Pneumatic Connection
- Adjustment Tag Line

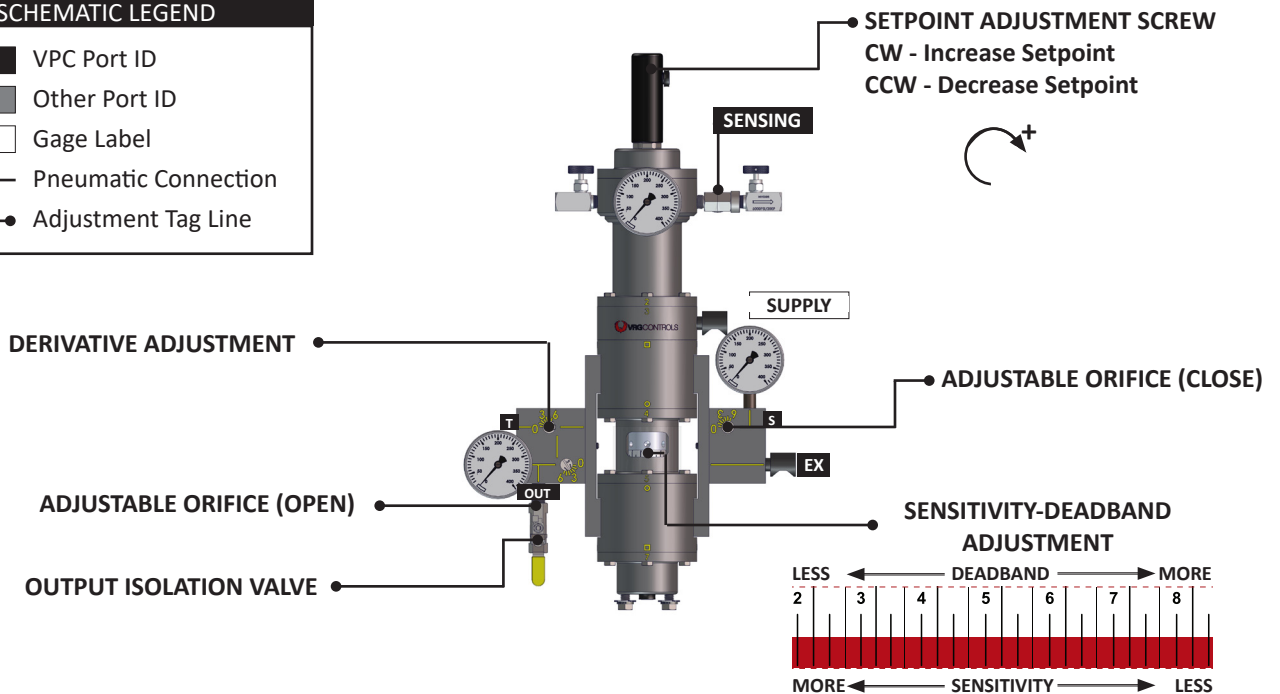

No. VPC	Actuator	Actuator Mode	Positioner	Accessory	Discharge
9 VPC-SA-BV-ID (REV)	Spring Piston	Spring Closed	-	BOOSTER	ATM

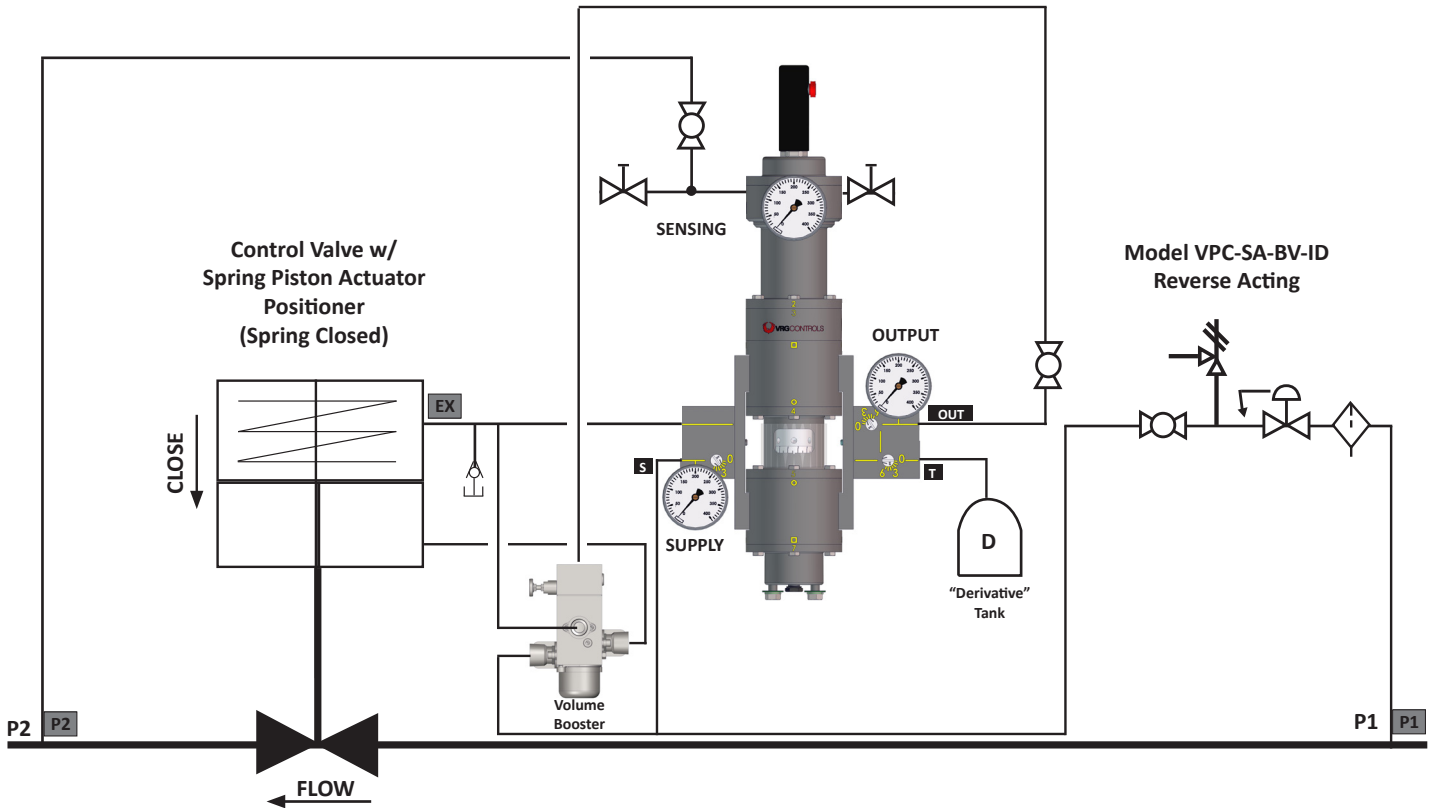

SCHEMATIC LEGEND

- TEXT** VPC Port ID
- TEXT** Other Port ID
- TEXT** Gage Label
- Pneumatic Connection
- Adjustment Tag Line

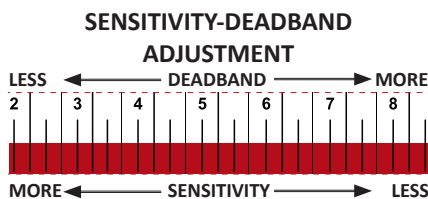
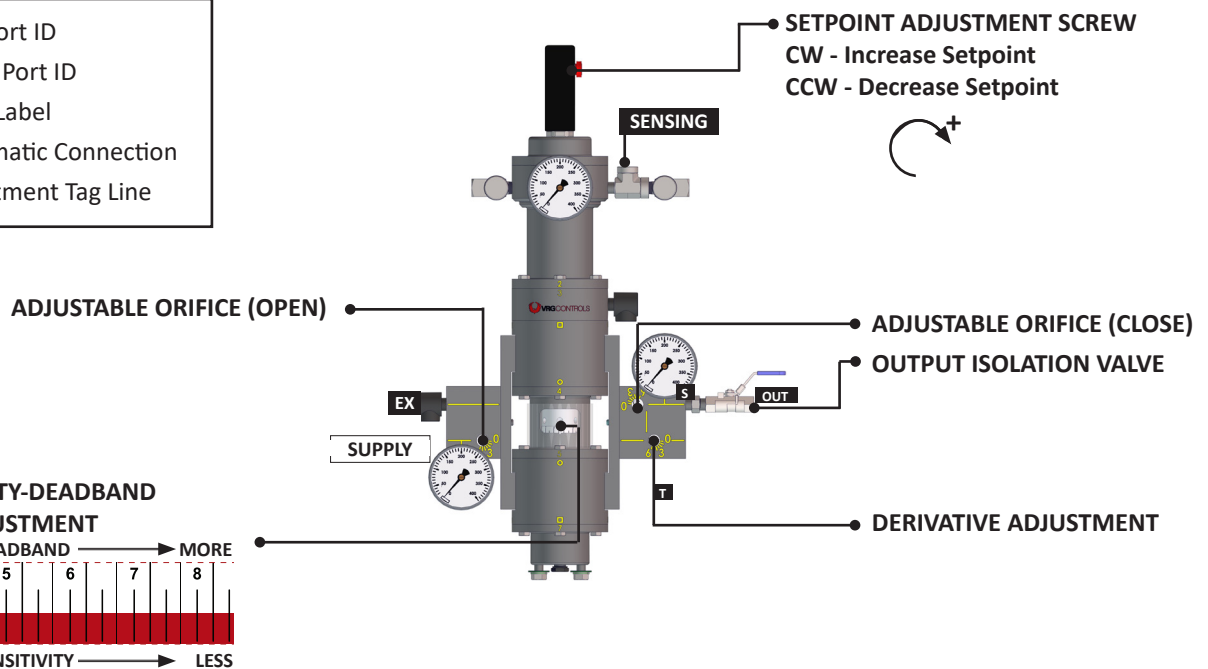

No. VPC	Actuator	Actuator Mode	Positioner	Accessory	Discharge
9A VPC-SA-BV-ID (REV)	Spring Piston	Spring Closed	-	BOOSTER +VMO	ATM

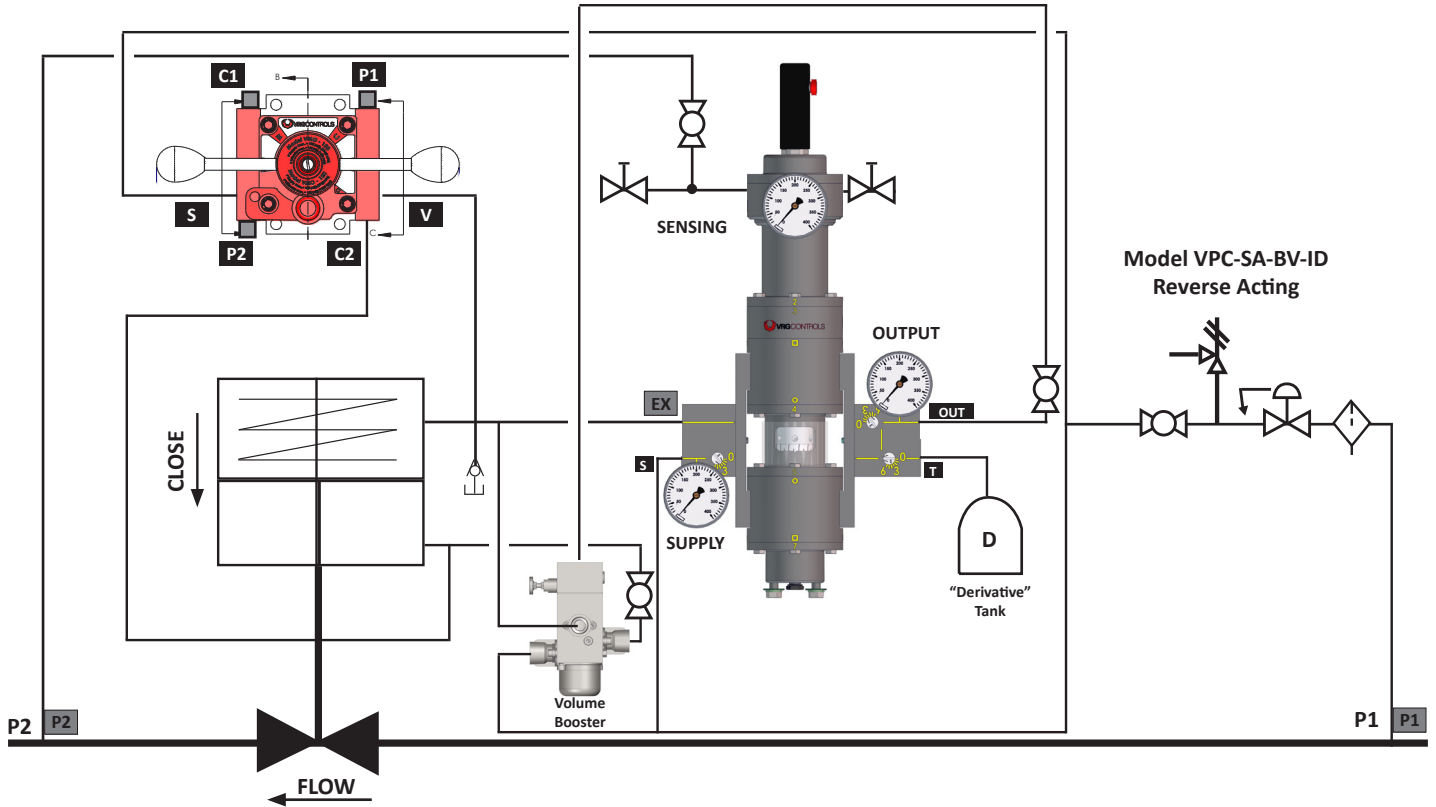

SCHEMATIC LEGEND

- TEXT** VPC Port ID
- TEXT** Other Port ID
- TEXT** Gage Label
- Pneumatic Connection
- Adjustment Tag Line

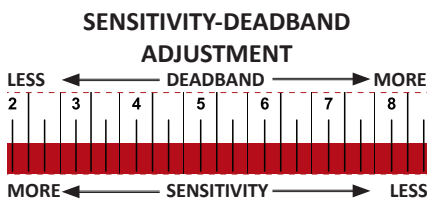
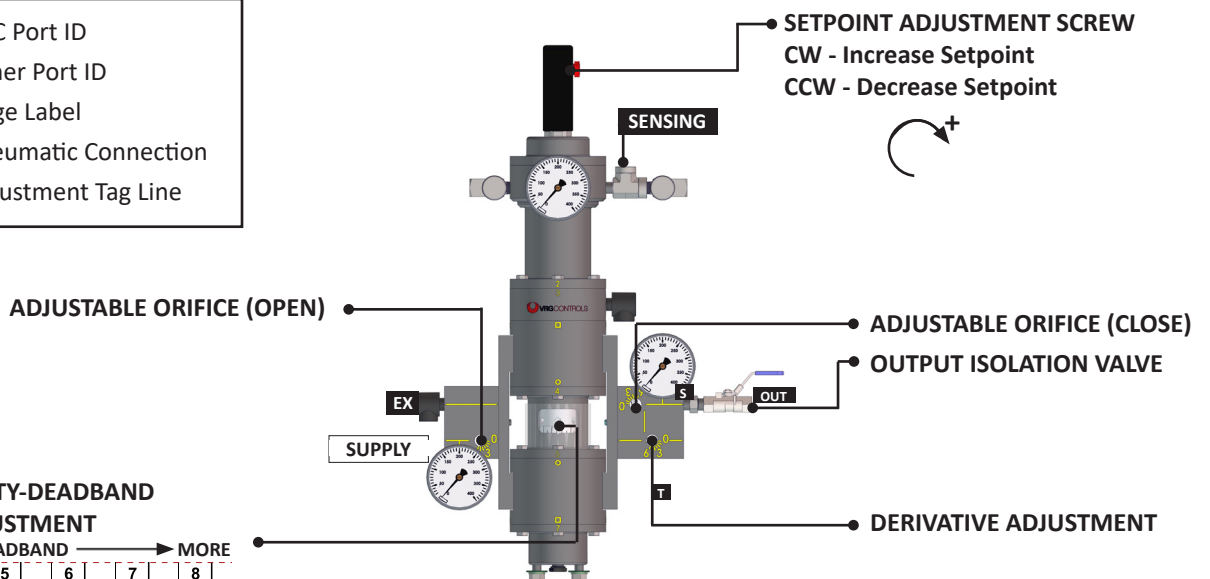

No. VPC	Actuator	Actuator Mode	Positioner	Accessory	Discharge
10 VPC-SA-BV (DIR)	Spring Diaphragm	Spring Open	-	-	ATM

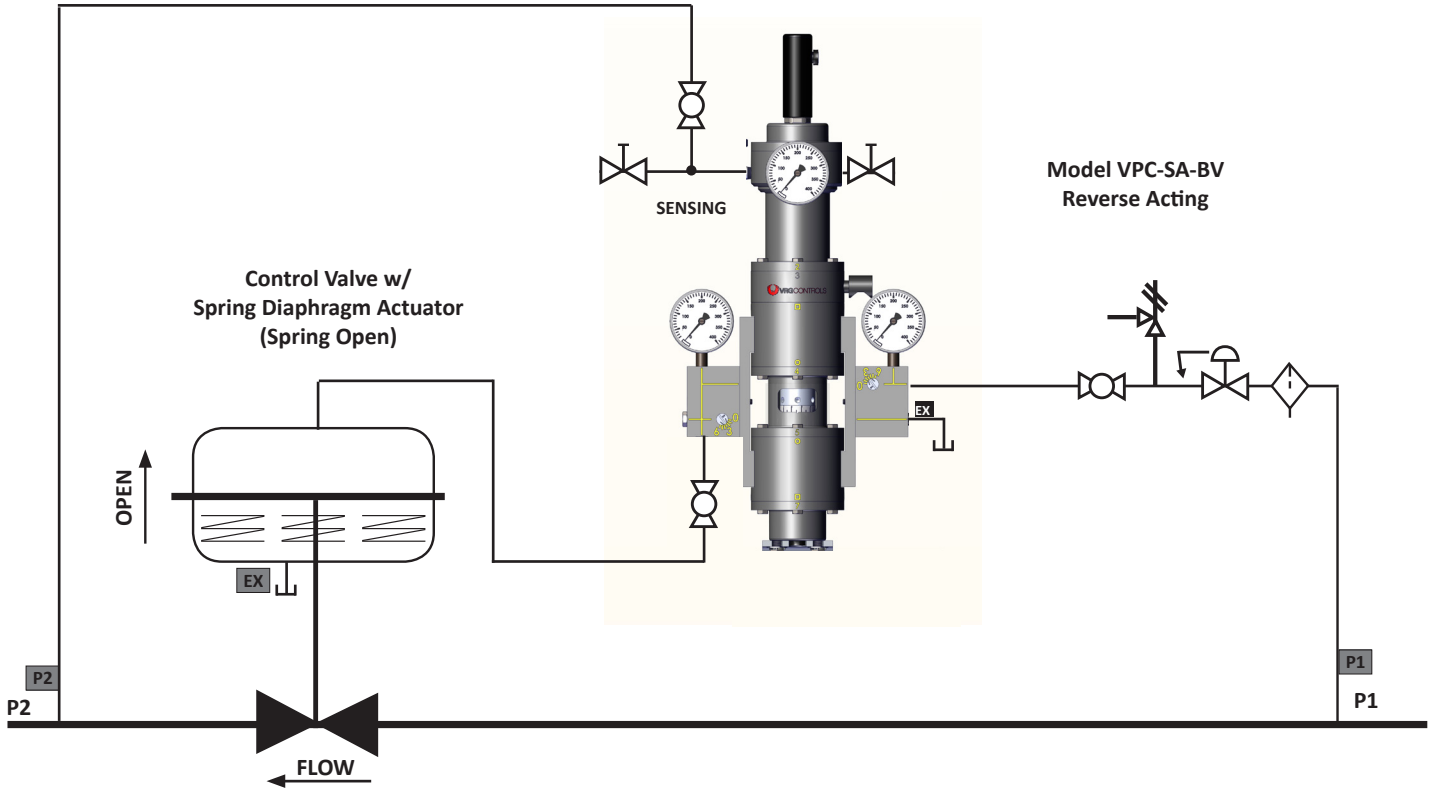

SCHEMATIC LEGEND

- TEXT** VPC Port ID
- TEXT** Other Port ID
- TEXT** Gage Label
- Pneumatic Connection
- Adjustment Tag Line

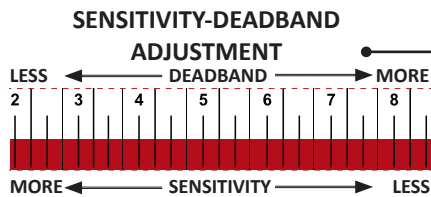
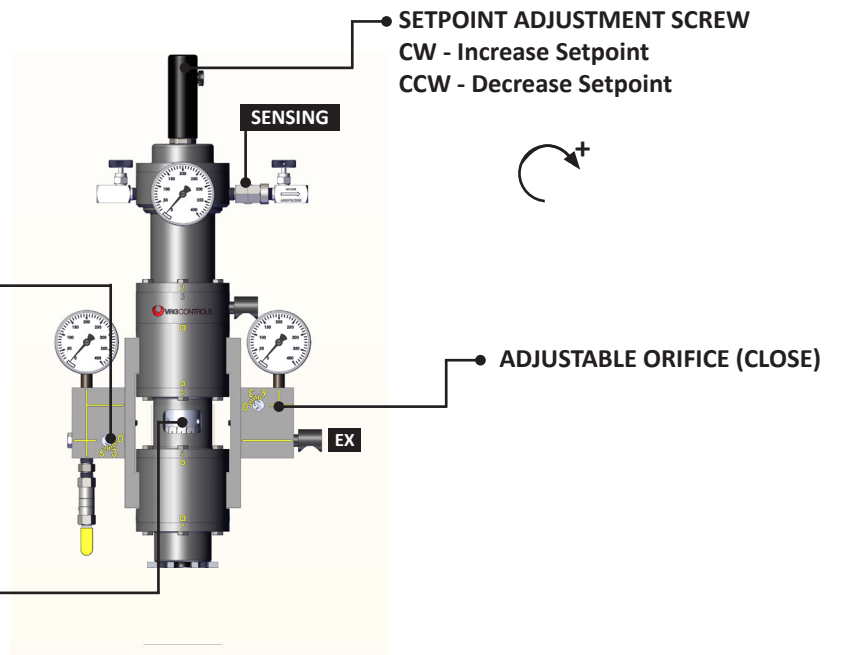

No. VPC	Actuator	Actuator Mode	Positioner	Accessory	Discharge
10A VPC-SA-BV-ID (DIR)	Spring Diaphragm	Spring Open	-	VMO	ATM

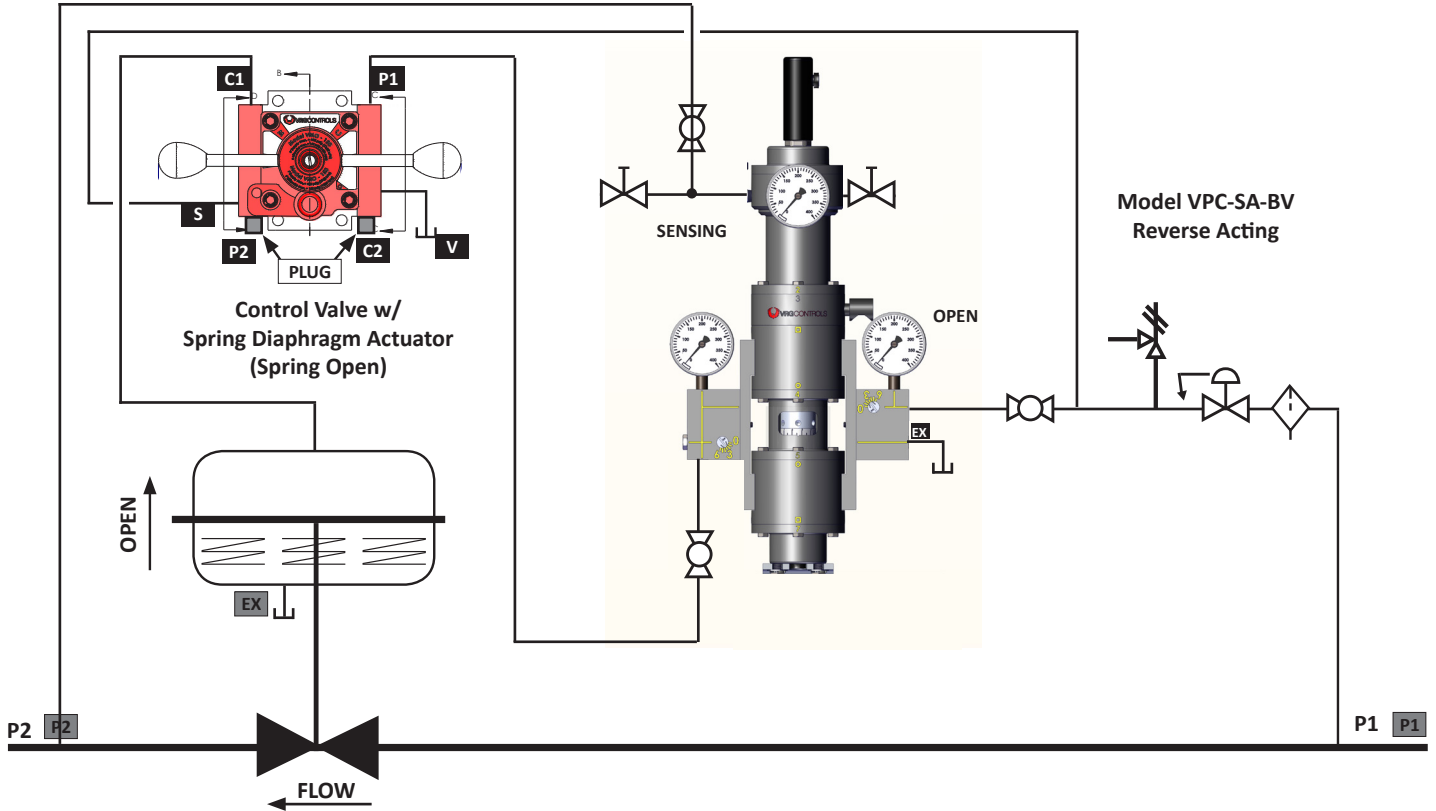

SCHEMATIC LEGEND

- TEXT VPC Port ID
- TEXT Other Port ID
- TEXT Gage Label
- Pneumatic Connection
- Adjustment Tag Line

ADJUSTABLE ORIFICE (OPEN)

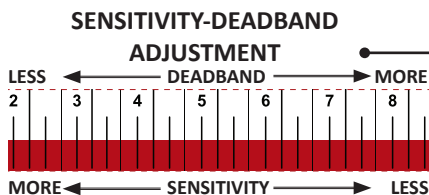
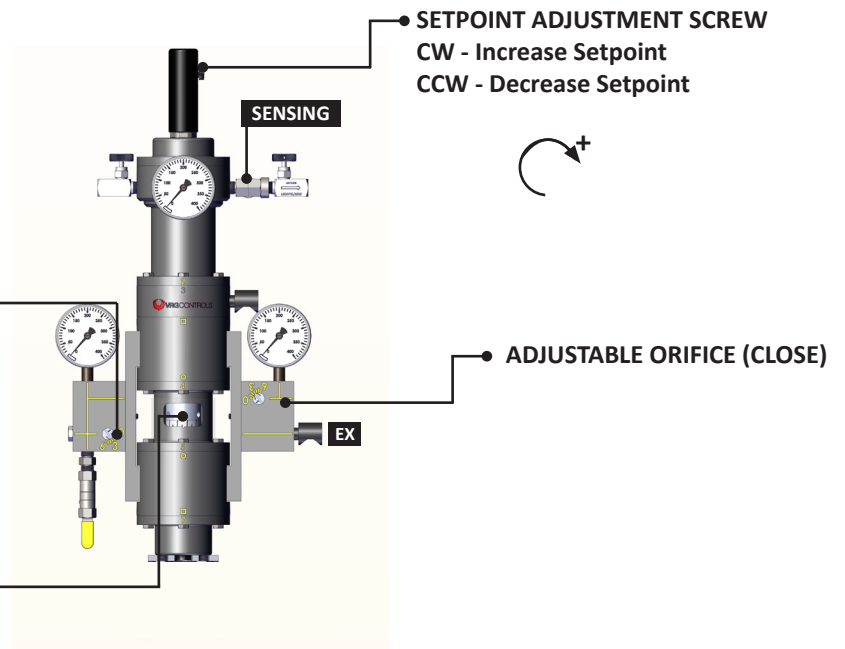

No. VPC	Actuator	Actuator Mode	Positioner	Accessory	Discharge
11 VPC-SA-BV (REV)	Spring Diaphragm	Spring Closed	-	-	ATM

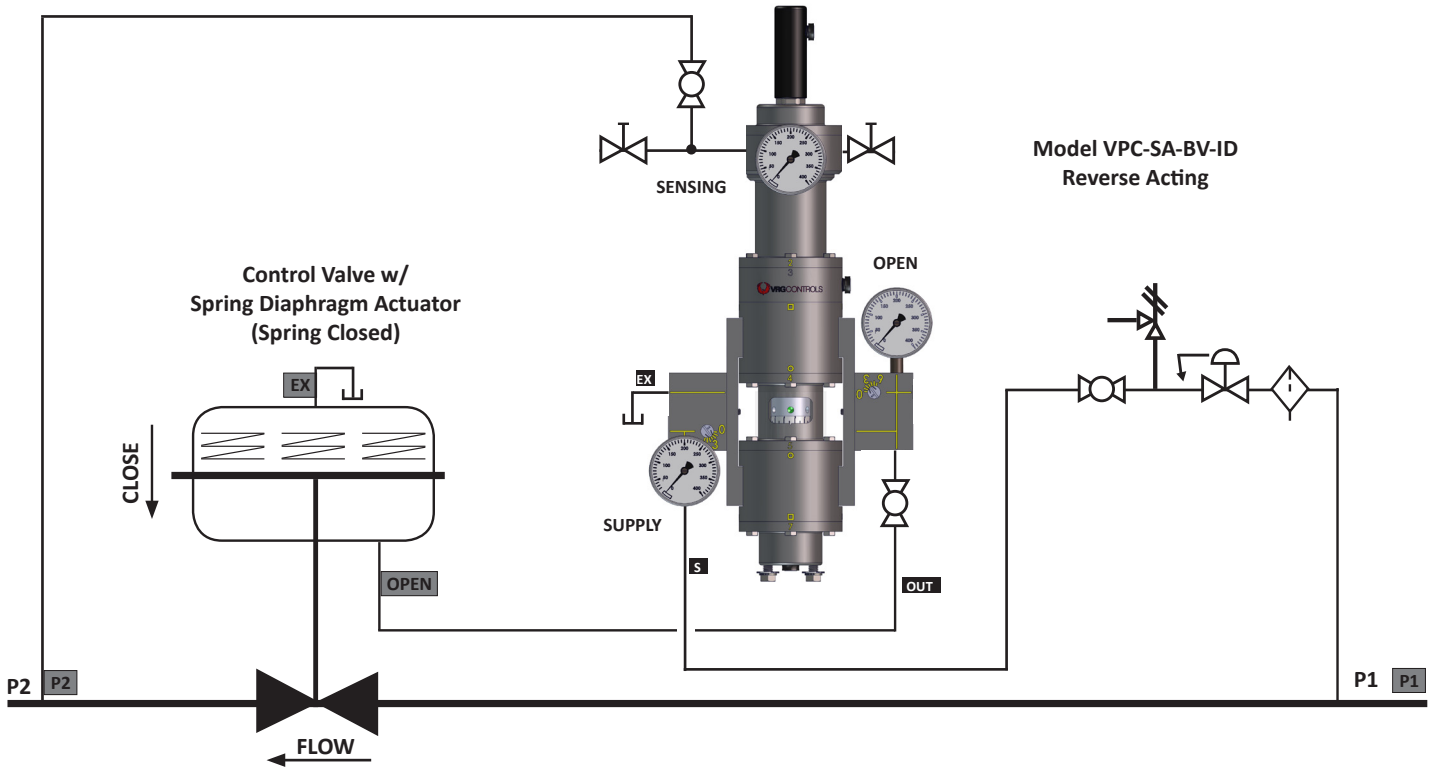

SCHEMATIC LEGEND

- TEXT** VPC Port ID
- TEXT** Other Port ID
- TEXT** Gage Label
- Pneumatic Connection
- Adjustment Tag Line

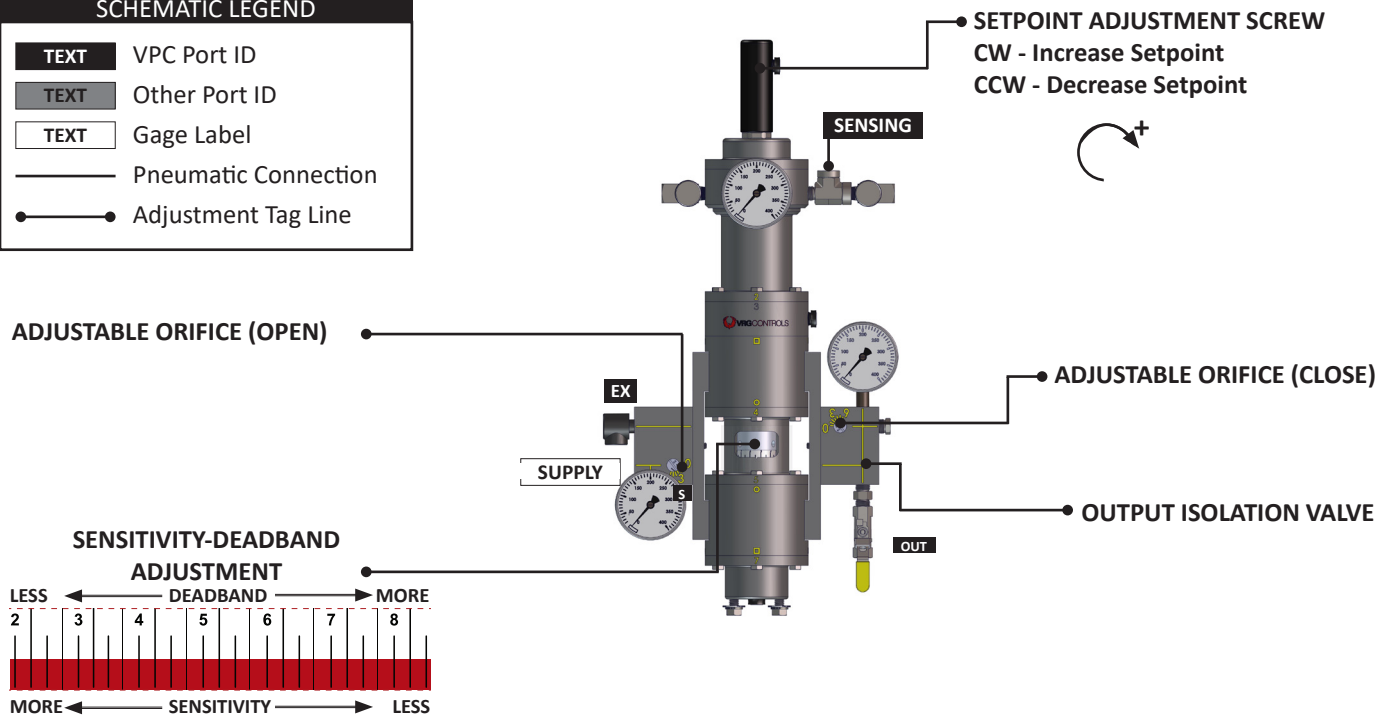

No. VPC	Actuator	Actuator Mode	Positioner	Accessory	Discharge
11A VPC-SA-BV-ID (REV)	Spring Piston	Spring Closed	-	VMO	ATM

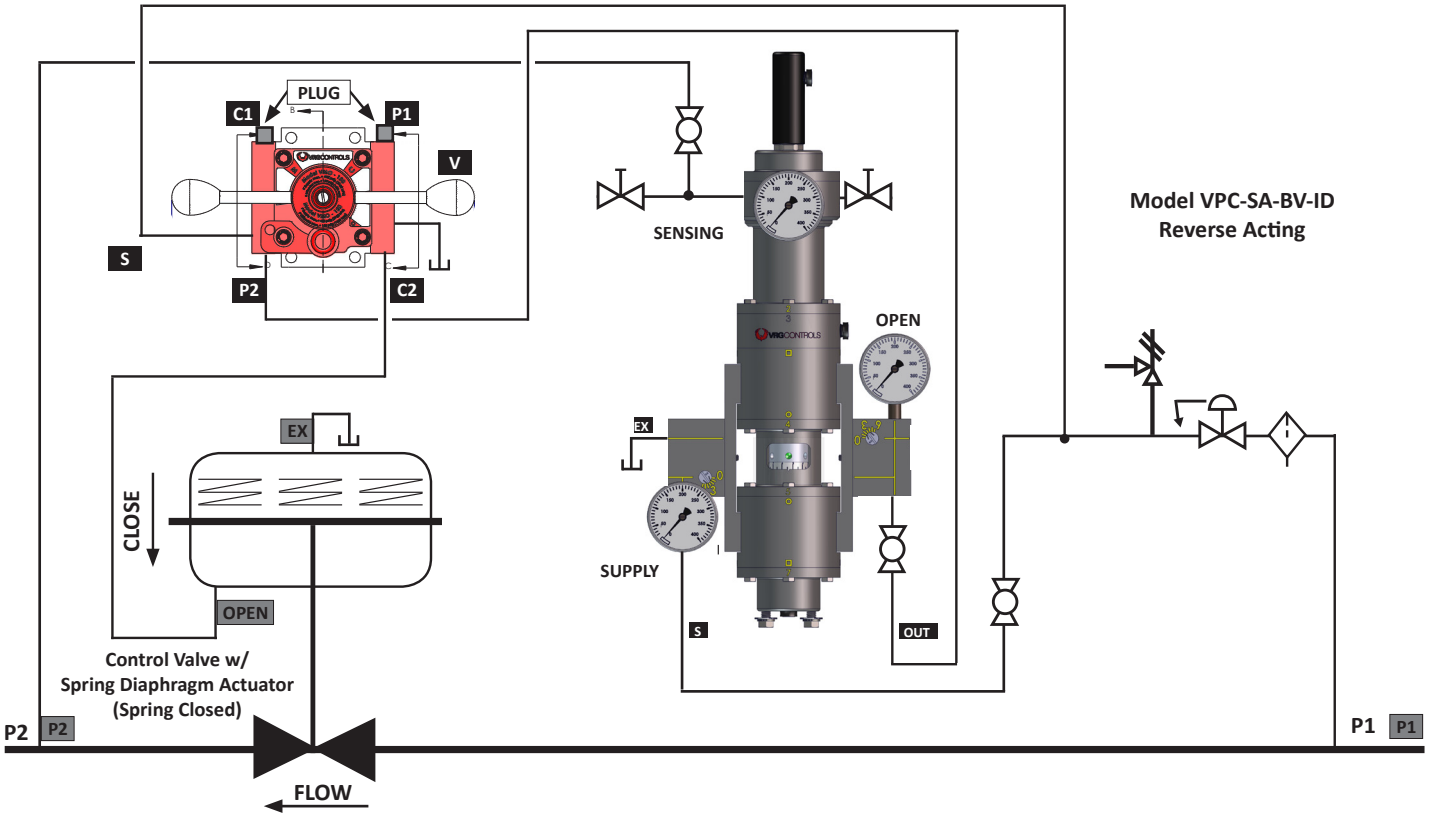

SCHEMATIC LEGEND

- TEXT** VPC Port ID
- TEXT** Other Port ID
- TEXT** Gage Label
- Pneumatic Connection
- Adjustment Tag Line

ADJUSTABLE ORIFICE (OPEN)

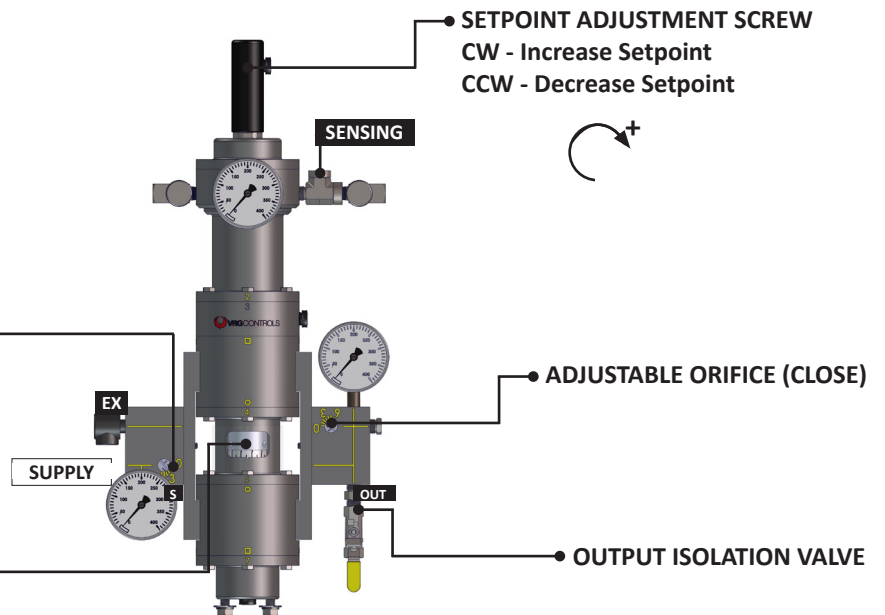
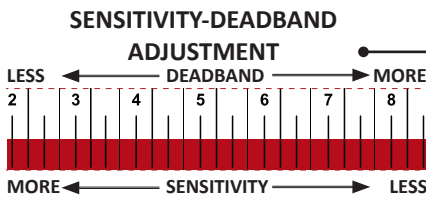

No. VPC	Actuator	Actuator Mode	Positioner	Accessory	Discharge
12 VPC-SA-BV-ID (DIR)	Spring Diaphragm	Spring Open	-	BOOSTER	ATM

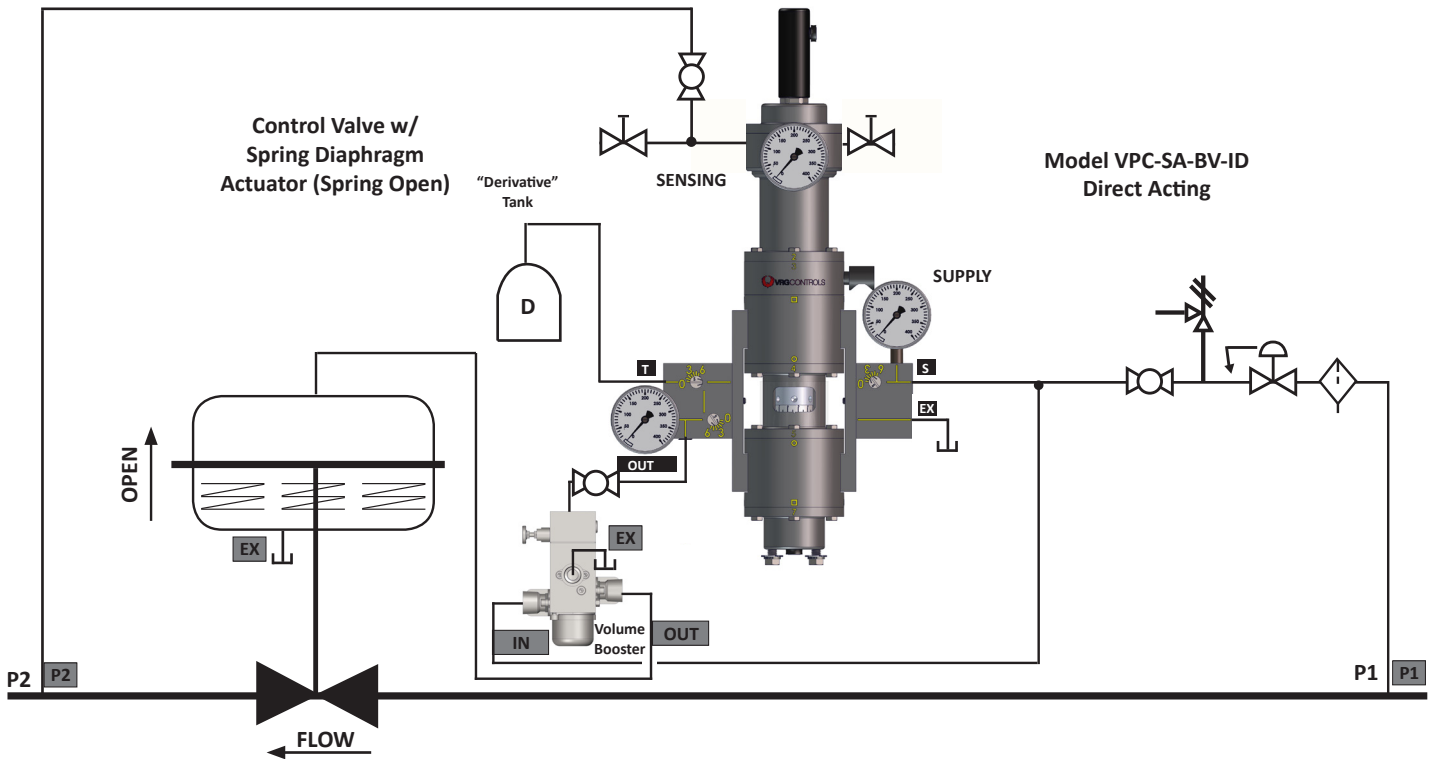

SCHEMATIC LEGEND

- TEXT VPC Port ID
- TEXT Other Port ID
- TEXT Gage Label
- Pneumatic Connection
- Adjustment Tag Line

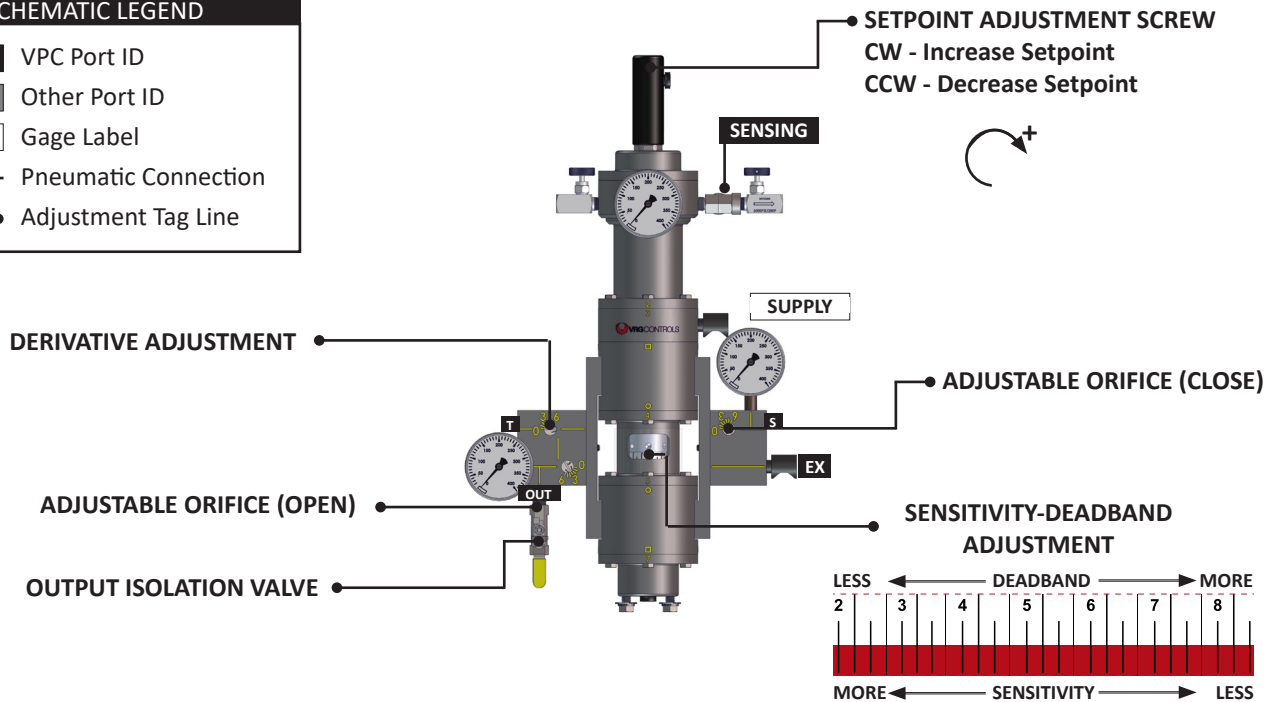

No. VPC	Actuator	Actuator Mode	Positioner	Accessory	Discharge
12A VPC-SA-BV-ID (DIR)	Spring Diaphragm	Spring Open	-	BOOSTER +VMO	ATM

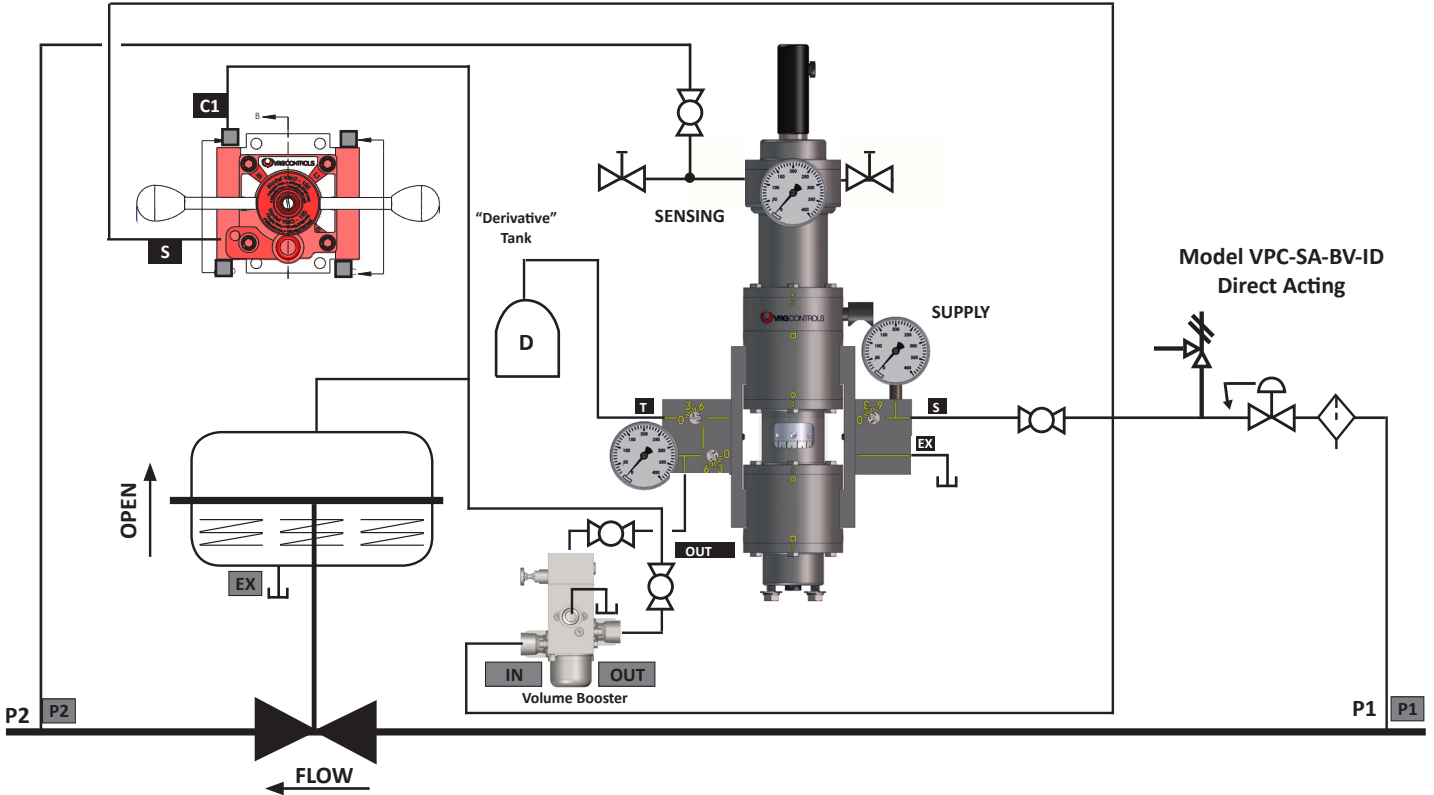

SCHEMATIC LEGEND

- TEXT VPC Port ID
- TEXT Other Port ID
- TEXT Gage Label
- Pneumatic Connection
- Adjustment Tag Line

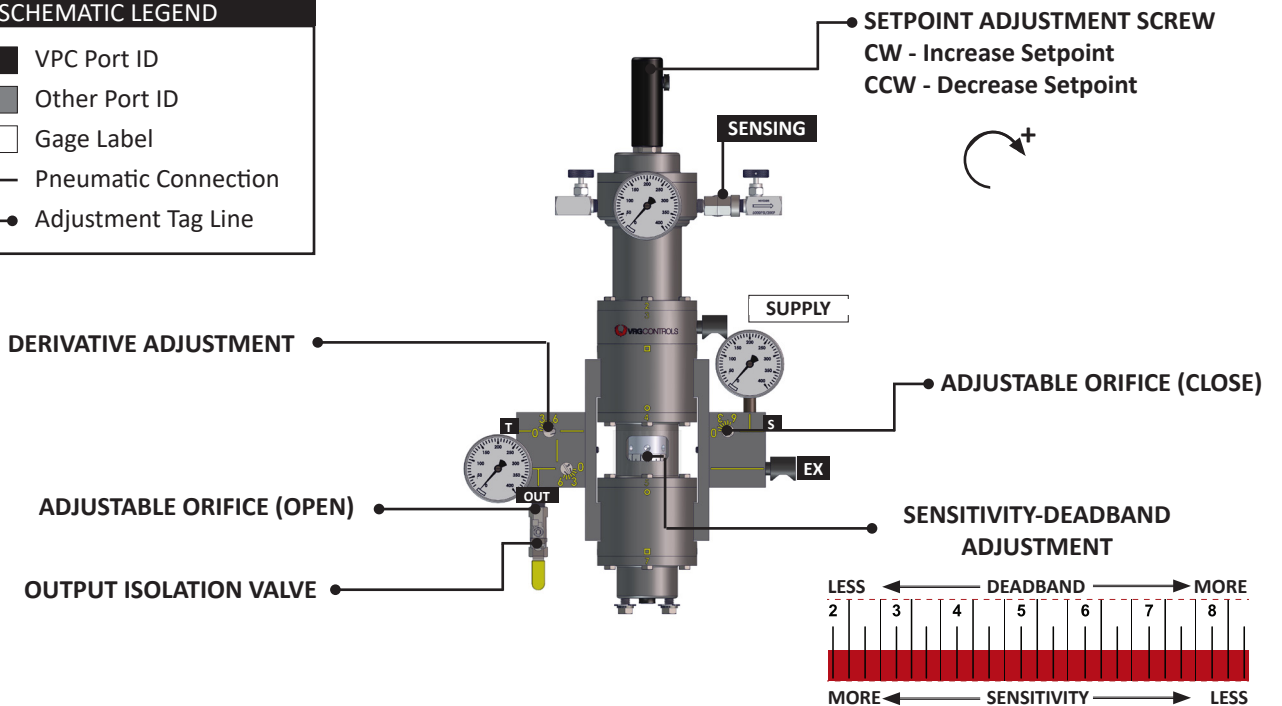

No. VPC	Actuator	Actuator Mode	Positioner	Accessory	Discharge
13 VPC-SA-BV-ID (REV)	Spring Diaphragm	Spring Closed	-	BOOSTER	ATM

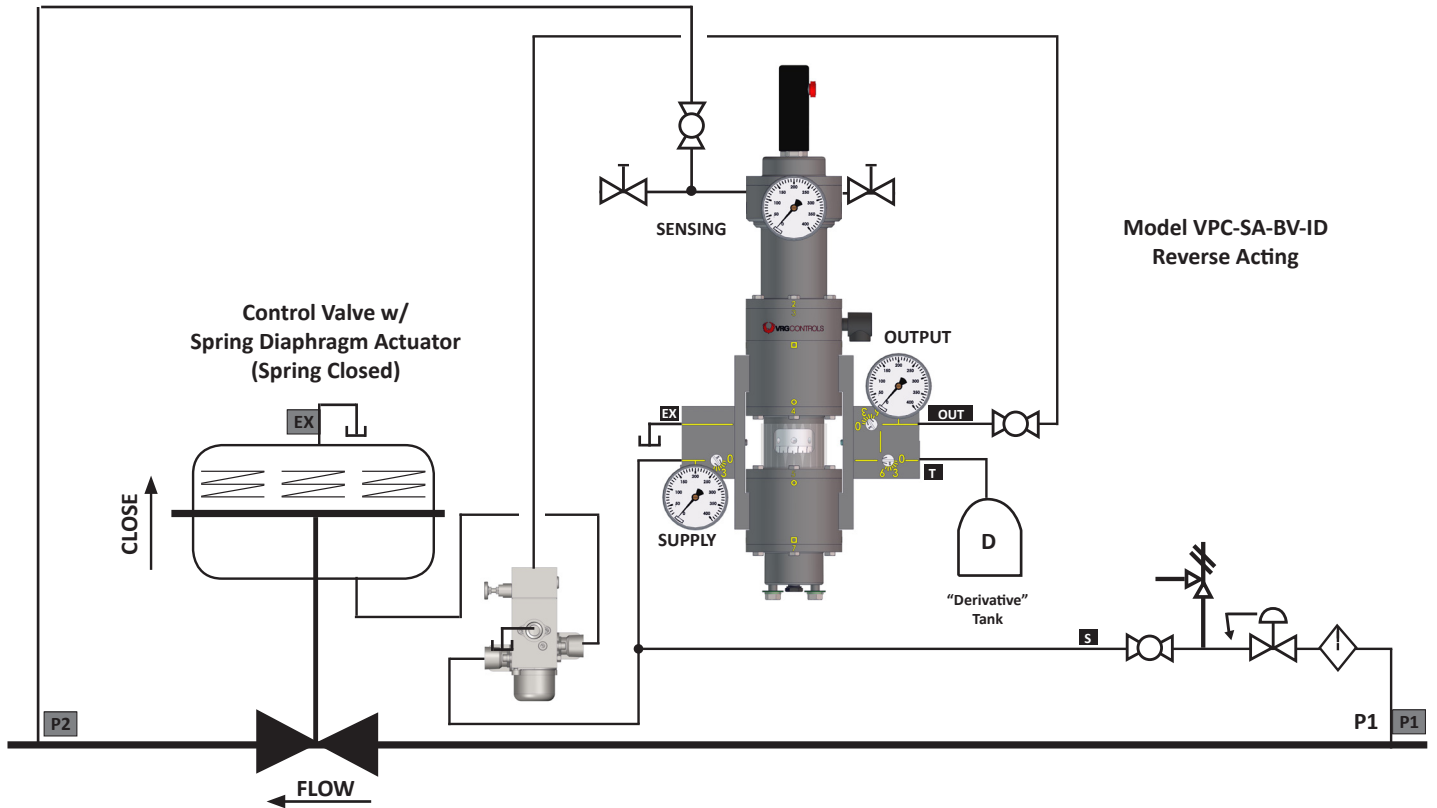

SCHEMATIC LEGEND

- TEXT** VPC Port ID
- TEXT** Other Port ID
- TEXT** Gage Label
- Pneumatic Connection
- Adjustment Tag Line

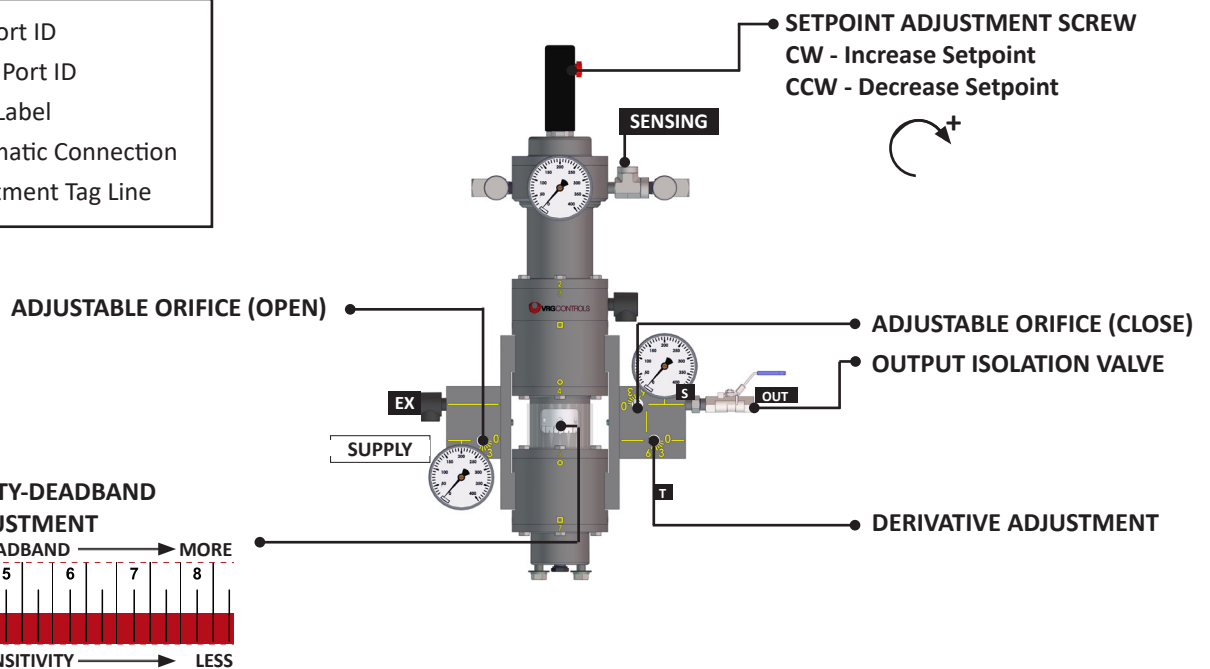

No. VPC	Actuator	Actuator Mode	Positioner	Accessory	Discharge
13A VPC-SA-BV-ID (REV)	Spring Diaphragm	Spring Close	-	BOOSTER +VMO	ATM

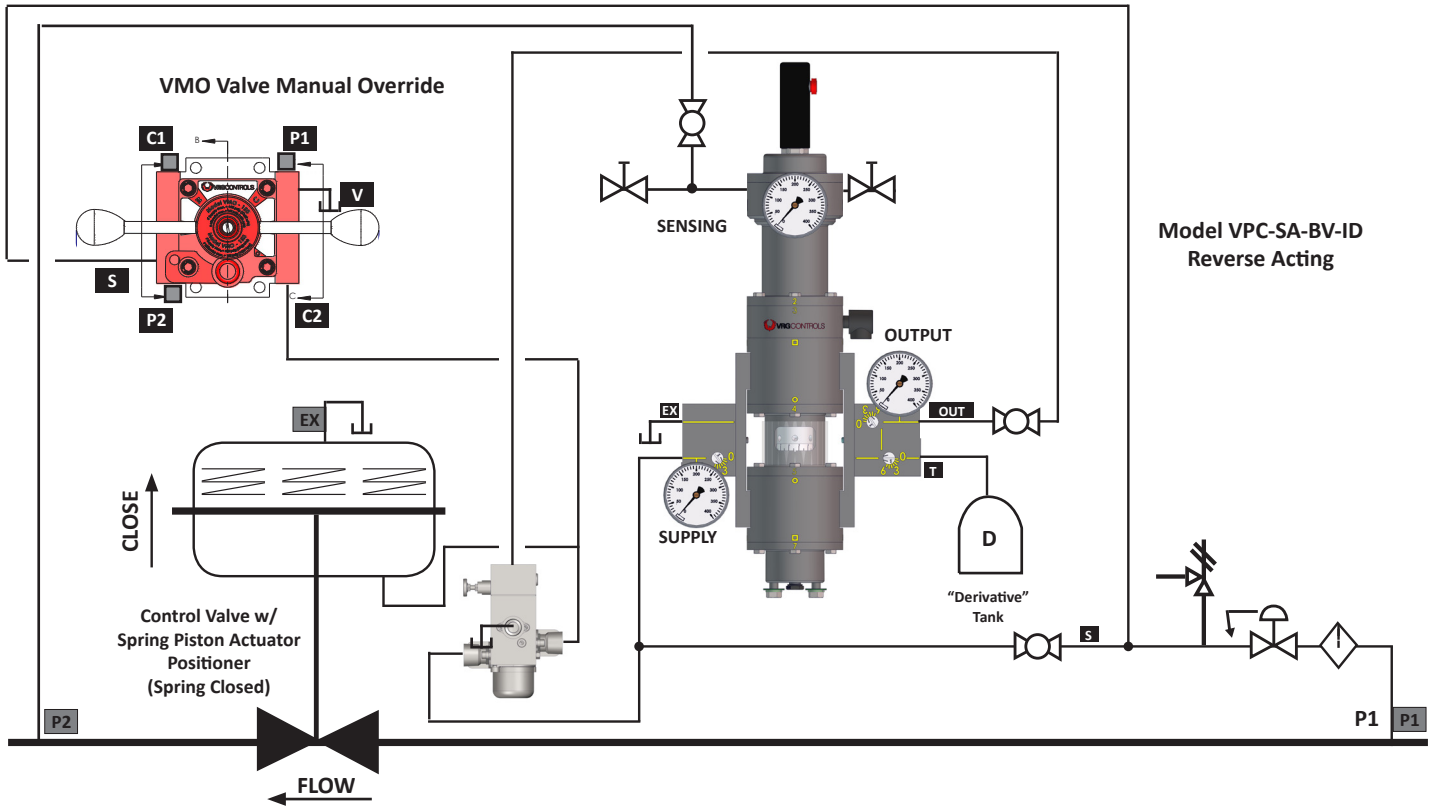

SCHEMATIC LEGEND

- TEXT** VPC Port ID
- TEXT** Other Port ID
- TEXT** Gage Label
- Pneumatic Connection
- Adjustment Tag Line

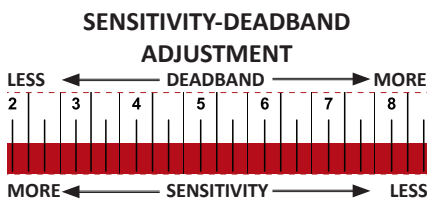
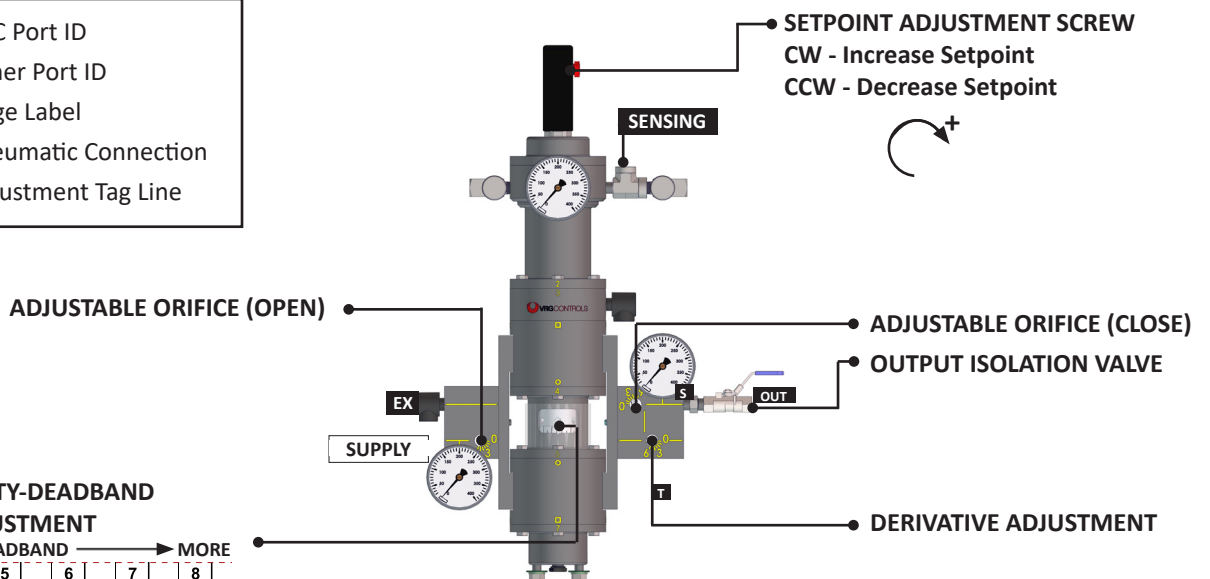

No. VPC	Actuator	Actuator Mode	Positioner	Accessory	Discharge
14 VPC-SA-BV-ID (DIR)	Spring Diaphragm	Spring Open	-	-	ATM

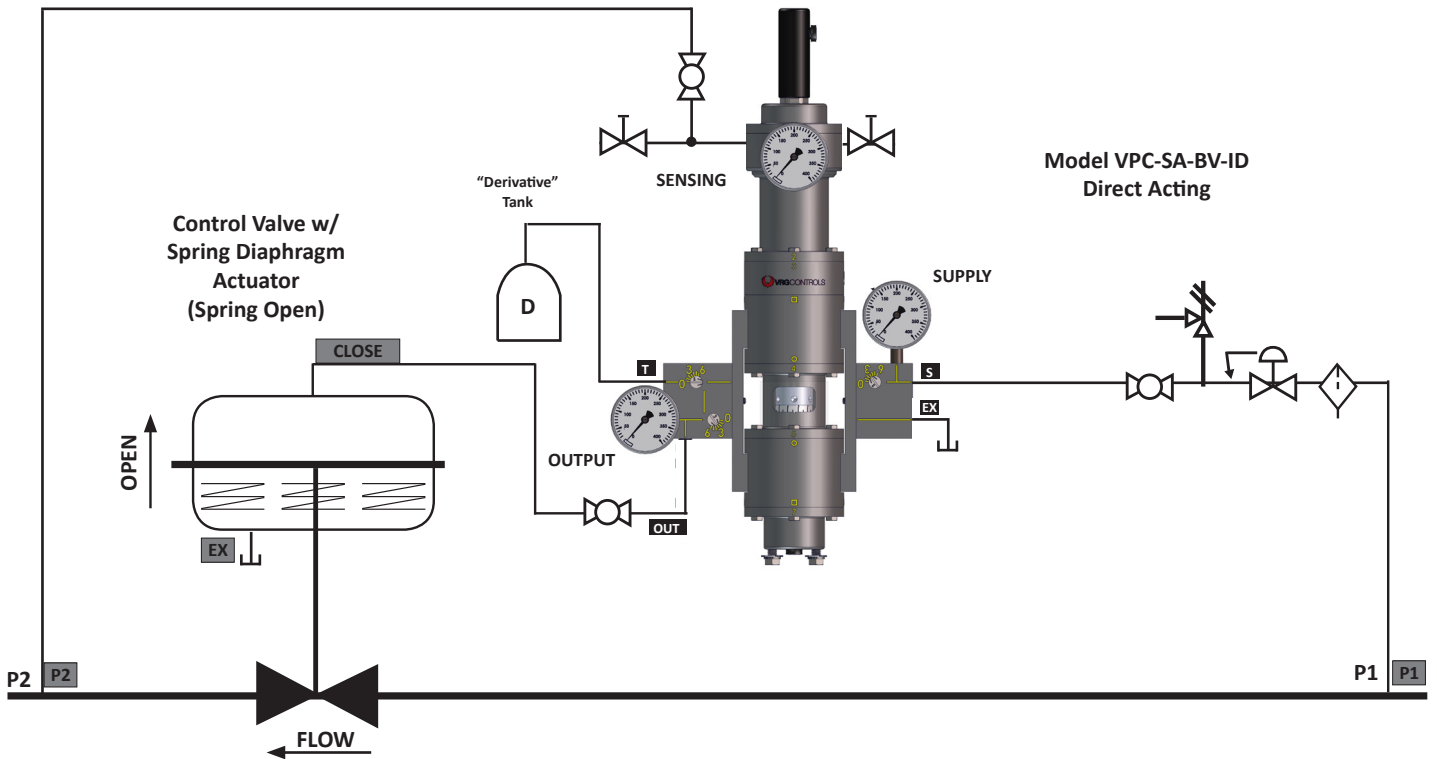

SCHEMATIC LEGEND

- TEXT** VPC Port ID
- TEXT** Other Port ID
- TEXT** Gage Label
- Pneumatic Connection
- Adjustment Tag Line

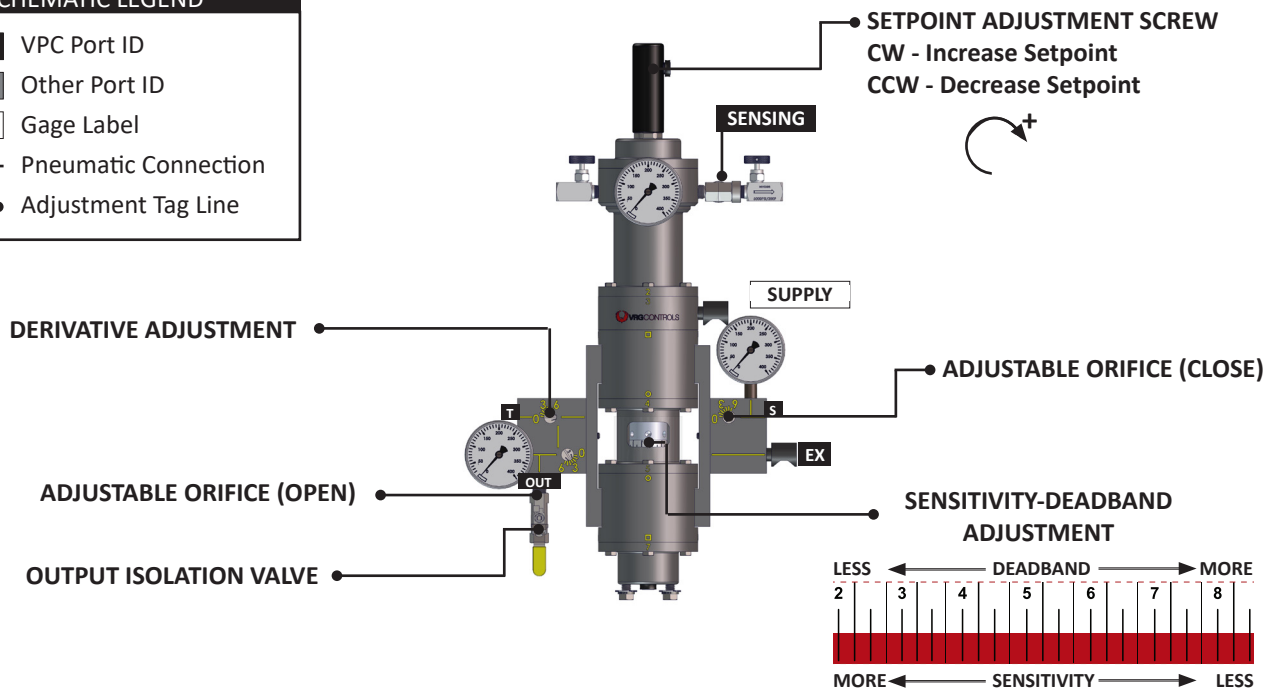

No. VPC	Actuator	Actuator Mode	Positioner	Accessory	Discharge
14A VPC-SA-BV-ID (DIR)	Spring Diaphragm	Spring Open	-	VMO	ATM

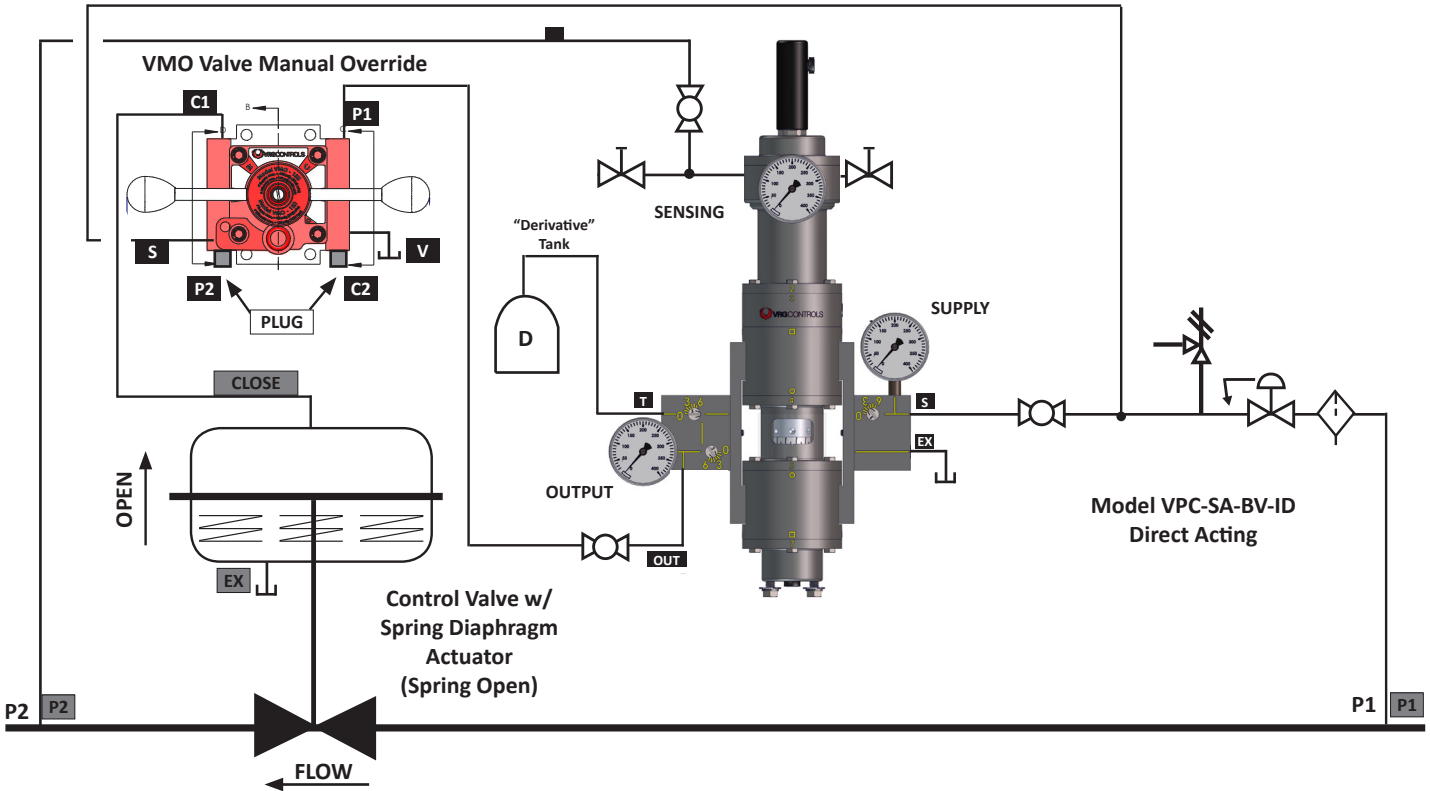

SCHEMATIC LEGEND

- TEXT** VPC Port ID
- TEXT** Other Port ID
- TEXT** Gage Label
- Pneumatic Connection
- Adjustment Tag Line

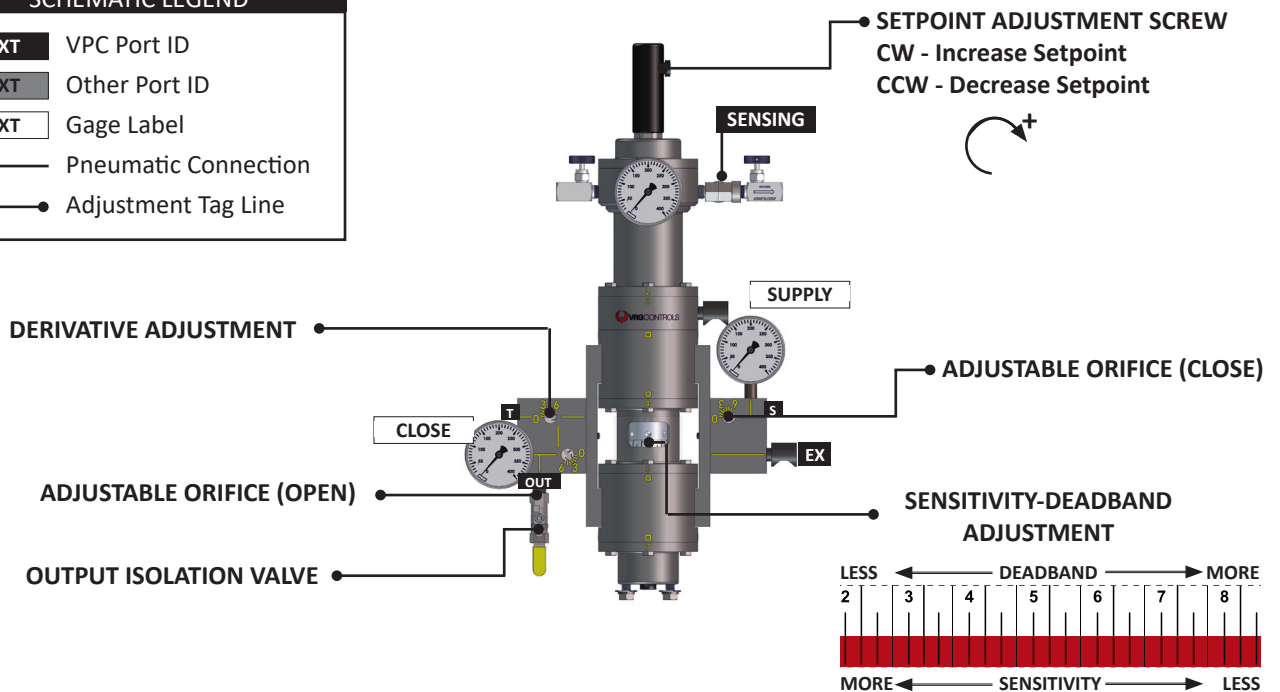

No. VPC	Actuator	Actuator Mode	Positioner	Accessory	Discharge
15 VPC-SA-BV-ID (REV)	Spring Diaphragm	Spring Closed	-	-	ATM

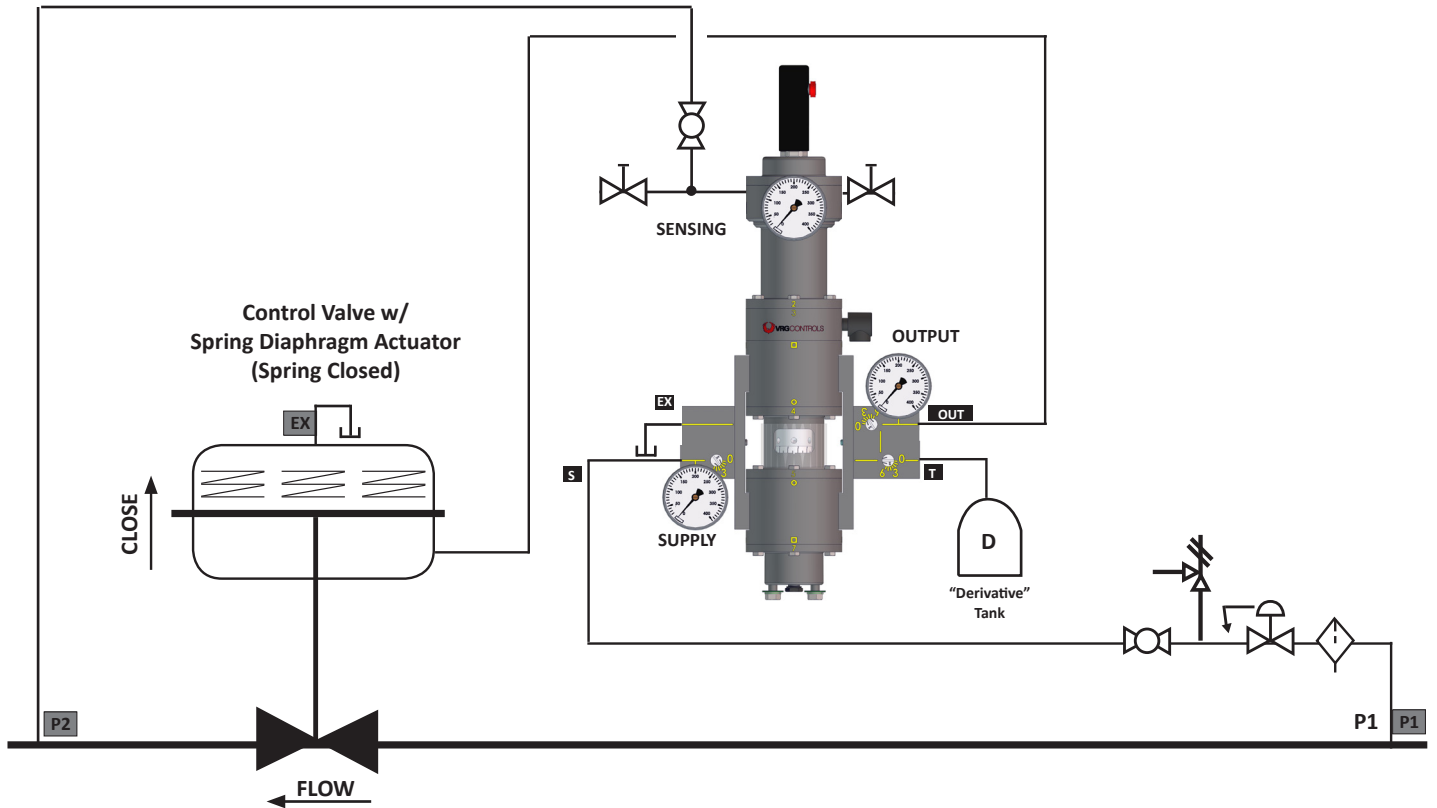

SCHEMATIC LEGEND

- TEXT** VPC Port ID
- TEXT** Other Port ID
- TEXT** Gage Label
- Pneumatic Connection
- Adjustment Tag Line

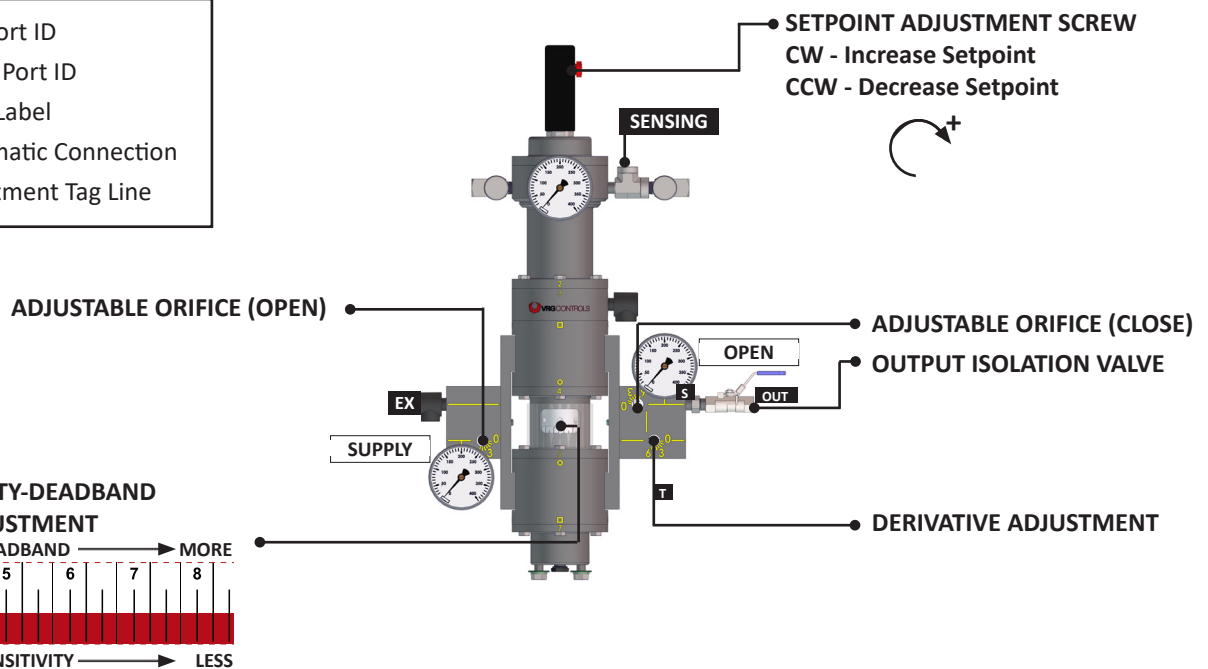

No. VPC	Actuator	Actuator Mode	Positioner	Accessory	Discharge
15A VPC-SA-BV-ID (REV)	Spring Diaphragm	Spring Closed	-	VMO	ATM

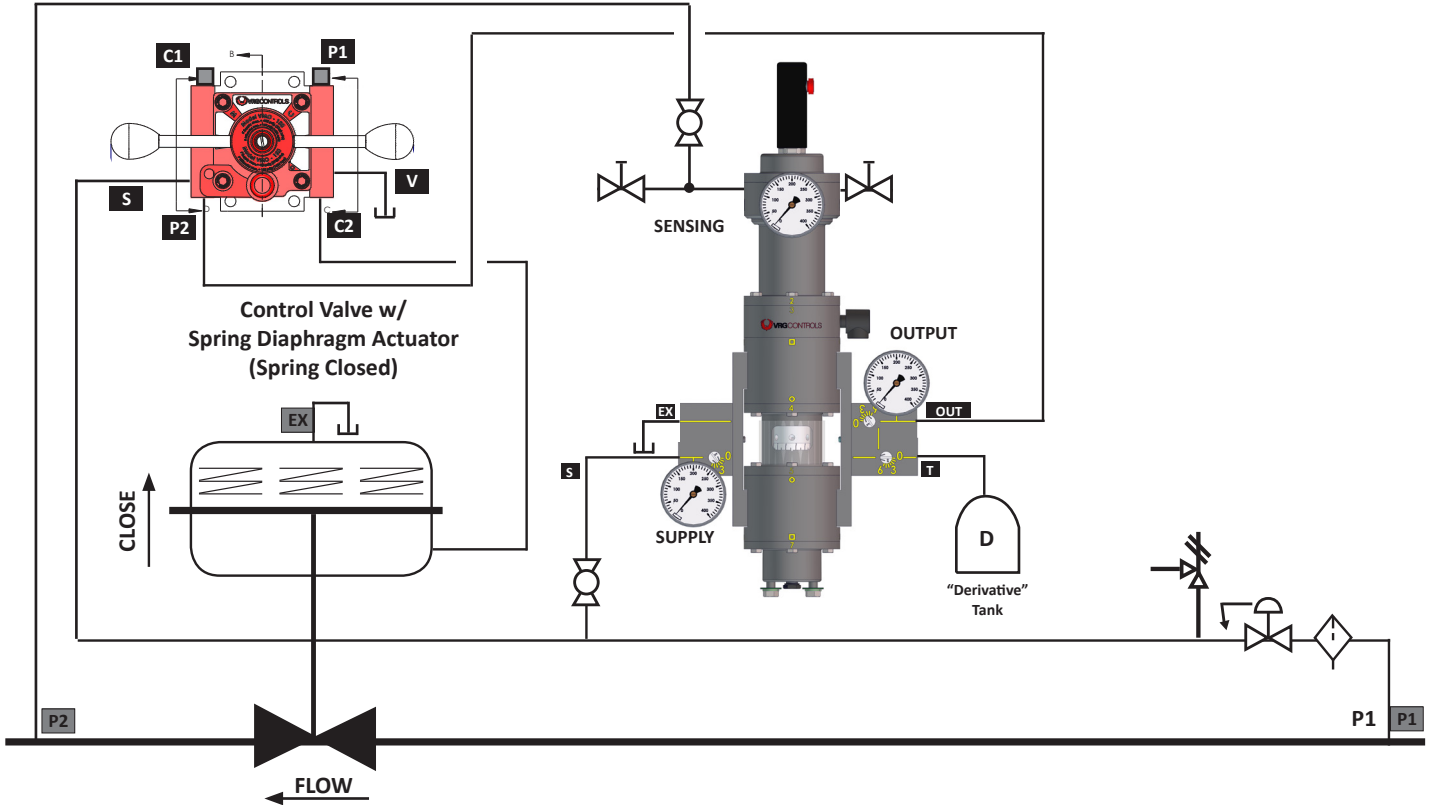

SCHEMATIC LEGEND

- TEXT** VPC Port ID
- TEXT** Other Port ID
- TEXT** Gage Label
- Pneumatic Connection
- Adjustment Tag Line

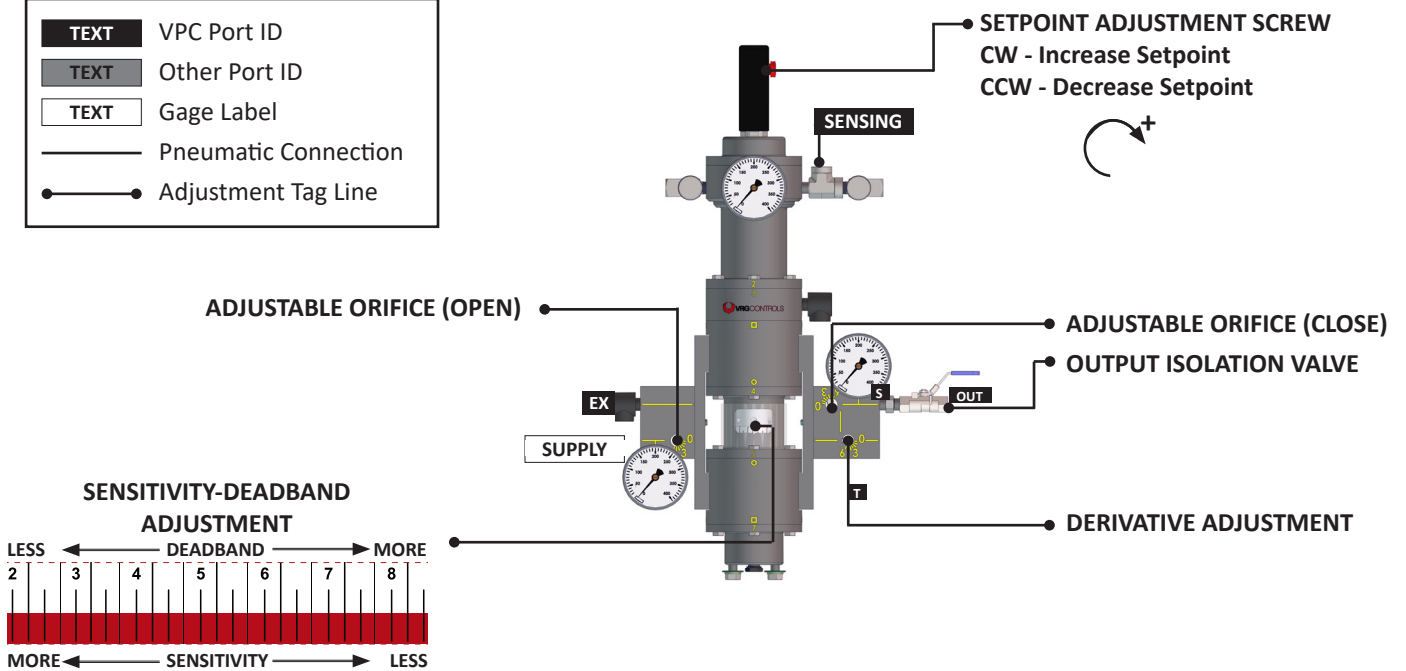

No. VPC	Actuator	Actuator Mode	Positioner	Accessory	Discharge
16 VPC-SA-GAP (DIR)	Spring Piston	Spring Closed	-	3-WAY VLV	ATM

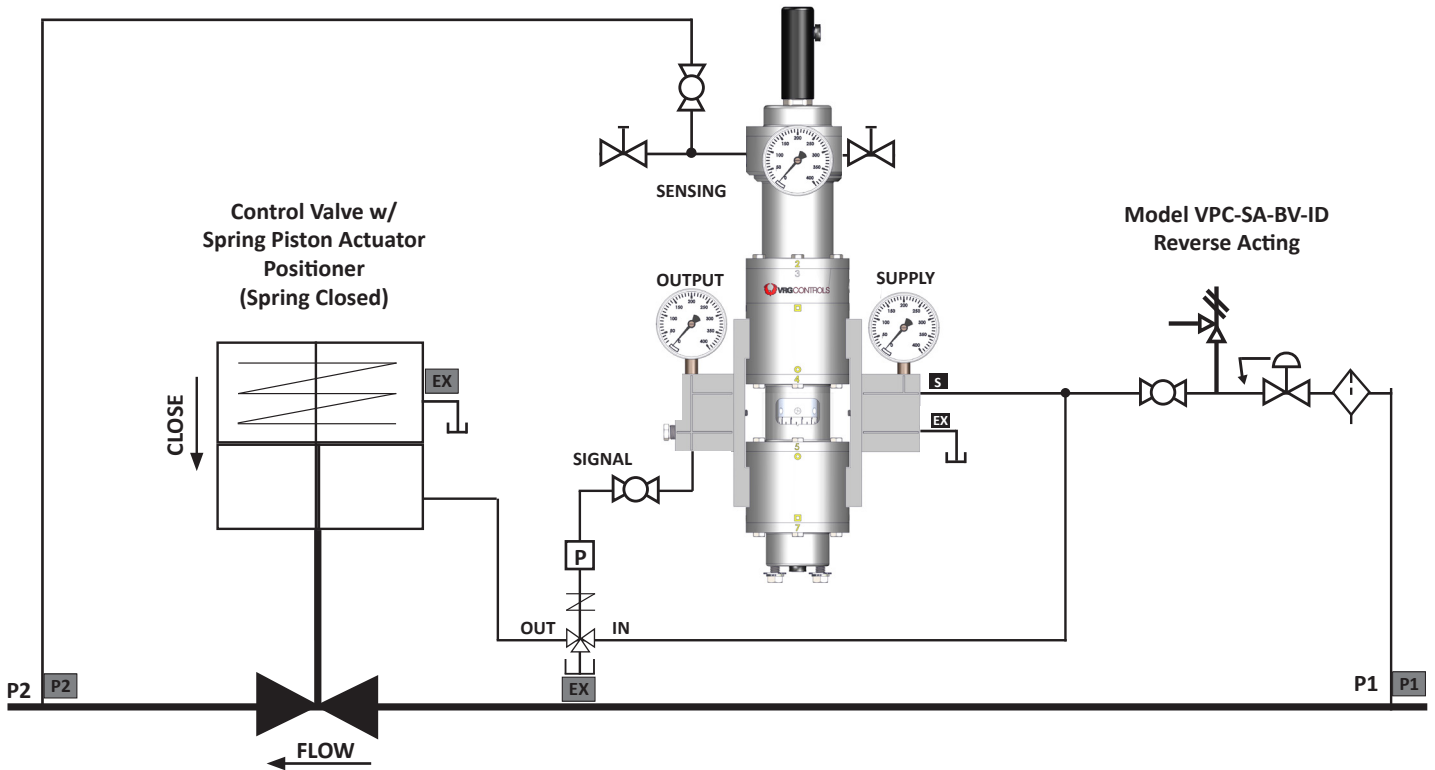

SCHEMATIC LEGEND

- TEXT VPC Port ID
- TEXT Other Port ID
- TEXT Gage Label
- Pneumatic Connection
- Adjustment Tag Line

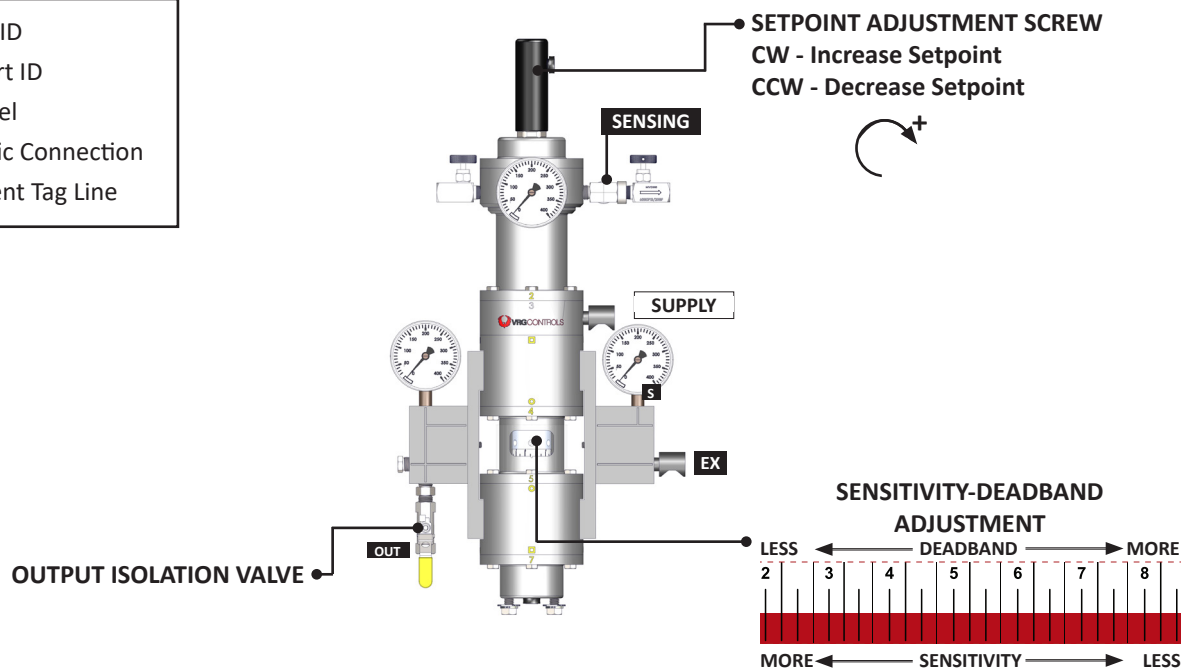

VPC "BV" Series Valve Gas Positioner Annual Maintenance Checklist

1. _____ VRG Controls recommends functional inspection of VPC "BV" Series Valve Pilot Controllers on an annual basis.
2. _____ For operating regulators, VRG Controls recommends complete replacement of elastomers of VPC "BV" Series Valve Pilot Controllers on a 5 year basis using VRG Controls repair kits.
3. _____ For monitor or standby regulators, VRG Controls recommends complete replacement of elastomers of VPC "BV" Series Valve Pilot Controllers on a 10 year basis using VRG Controls repair kits.
4. _____ Isolate and remove pressure from all VPC "BV" components. Clean and inspect Adjustable Orifice Assemblies. Repressurize as appropriate.
5. _____ Soap Test All Diaphragm Mating Surfaces And Adjustable Orifice Assembly to Check for Leaks.
6. _____ Check Integrity of VPC "BV" Pilot Balanced Valve/Seat Assemblies by increasing/decreasing the signal such that full differential pressure is achieved on CLOSE/OPEN gages.
7. _____ Replace Elastomers Utilizing VRG Controls VPC "BV" Series Repair Kit if leaks are found. See the Assembly Manual for the VPC "BV" Series Valve Pilot Controller.
8. _____ Check sensitivity of VPC "BV". Confirm proper cylinder balance pressures (OPEN / CLOSE Gages).
9. _____ Observe Operation Of All Gages And Replace If Defective.
10. _____ Perform Internal Friction Test (rotate the adjusting screw at setpoint) observe accurate movement of the output gauge in correct direction.

Note: *When increasing or decreasing the instrument signal, the output pressure should swing up and down respectively. When changing direction of the false instrument signal, the output pressure should immediately reverse direction. Any "bump" or initial reaction of the gauge in the wrong direction indicates friction within the components of the positioner. In the case where friction is a problem the positioner must be disassembled and rebuilt to eliminate it.*

11. _____ Inspect And Verify Proper Operation Of All VPC "BV" Accessories.

Note: *It is not necessary to replace any elastomers in VRG Controls instrumentation or instrumentation accessories on a regular basis. Industry best practices promote rebuild using a VRG Controls spare parts kit on a 5-year frequency. VRG Controls suggested maintenance frequency should never supersede any mandated regulatory requirements or company mandated maintenance.*

12. _____ PLEASE PROVIDE VPC SERIAL NUMBER TO FACILITATE ASSISTANCE.

While this information is presented in good faith and believed to be accurate, VRG Controls LLC. does not guarantee satisfactory results from reliance upon such information. Nothing contained herein is to be construed as a warranty or guarantee, expressed or implied, regarding the performance merchantability, fitness or any other matter

with respect to the products, nor as a recommendation to use any product of process in conflict with any patent. VRG Controls LLC. reserves the right, without notice, to alter or improve the designs or specifications of the products described herein.

ADDRESS: VRG Controls, LLC.
Lake Zurich, IL 60047, USA
TOLL FREE: (800) 844-FLOW-VRG
FAX: (208) 246-0304
E-MAIL: sales@vrgcontrols.com
WEBSITE: vrgcontrols.com

