

Installation, Operation and Maintenance Manual

# WHEATLEY® Series 822/820 Swing Check Valve

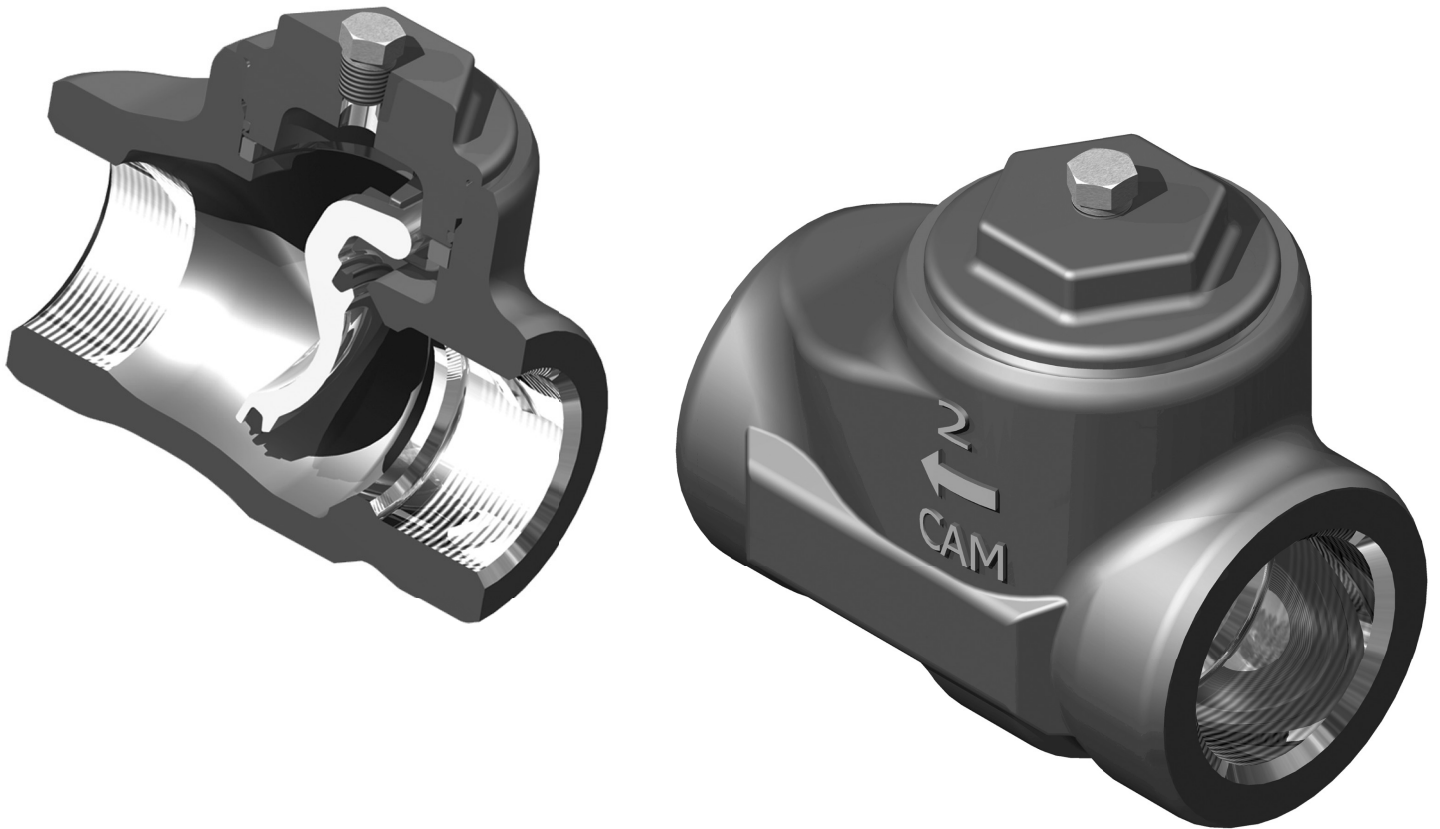

**WHEATLEY®**

## TABLE OF CONTENTS

### WHEATLEY® SERIES 822/820 CHECK VALVE

Description .....	3
Installation & Operation .....	5
Maintenance.....	6
Maintenance Schedule.....	7
Recommended Spare Parts.....	7

## DESCRIPTION

The Wheatley 822/820 swing check valve features a hinged stainless steel clapper with a lip type seal. The design allows the clapper to swing freely from the closed position to the fully opened position and back. The cover is threaded to the body and sealed with an O-ring. The cover is equipped with 1/4" NPT bonnet access port except sizes 1/2", 3/4", 1". The swing check valve is a full bore type that will pass a sphere with a nominal size not less than that specified in Table 1 of API 6D.

Due to the critical nature of pressurized piping systems it is recommended that the compatibility to the service of the metallic and non-metallic components be confirmed prior to installation. This valve is not recommended for slurry service.



### READ CAREFULLY BEFORE INSTALLING OR OPERATING THE VALVE

Hazards are inherent with the construction, operation, and maintenance of high pressure piping systems. The following information and precautions are provided to minimize these hazards:

1. The valve's nameplate indicates maximum operating pressure as well as minimum and maximum operating temperatures. The valve may be safely operated within these limits.
2. The valve's end connections are available in threaded (NPT), socket weld, and grooved configurations
3. If the valve is equipped with socket weld ends, it is recommended that the valve be disassembled prior to welding into the flow system. This will prevent damage to valve seals due to heat from welding. Removal of cover pipe plug and clapper seal are not required at disassembly. After welding, reassemble the valve according to the Reassembly Instructions on page six.
4. The valve has been factory pressure tested based on the nameplate maximum operating pressure.
5. These valves may be lifted with slings if required. Fittings and other devices, which may be attached to the valve, are not intended to be used as lifting points. Always follow local safety regulations when lifting heavy valves.
6. WHEATLEY valves are designed, manufactured, and tested under a certified quality system. Only quality parts and materials are used in the assembly of WHEATLEY valves. Pressure containing components are suitable for the minimum temperature marked on the nameplate. Factory certification is available.
7. If the valve, in service, is exposed to hazards such as traffic, wind, or earthquake loading, contact the factory, to confirm that the valve design is suitable for the application. The factory requires a complete description of the hazard before making any recommendations.

8. If the valve, in service, is exposed to hazards such as excessive piping system reaction forces and movements, contact the factory, to confirm that the valve design is suitable for the application. The factory requires a complete description of the hazard before making any recommendations.
9. If the valve, in service, is exposed to hazards such as corrosive or abrasive fluids or atmospheric conditions, contact the factory, to confirm that the valve design is suitable for the application. The factory requires a complete description of the hazard before making any recommendations.
10. The valve has been designed and manufactured so that under normal operating conditions hazards such as material fatigue, brittle fracture, creep rupture, or buckling will not occur. Do not operate the valve beyond the pressures and temperatures marked on the nameplate. The factory requires a complete description of the hazard before making any recommendations.
11. The user is responsible for minimizing other hazards associated with the construction, operation and maintenance of high pressure piping systems, such as:
  - a. Provisions for the release or blow off of pressure.
  - b. Prevention of physical access to system under pressure
  - c. Prevention of physical access to surfaces of extreme temperature
  - d. Provisions for inspection
  - e. Provisions for draining and venting
  - f. Provisions for filling
  - g. Provisions for equipment access
  - h. Prevention of over-pressurization, over-heating, and over-filling.
  - i. Provisions for fault indication
12. The user is responsible for meeting applicable local safety regulations.

## INSTALLATION & OPERATION

**NOTE:** If system hydrostatic tests are to be performed at pressures exceeding the rated working pressure of the valve, the valve should be pressurized from the upstream side. This prevents exposure of the clapper to these pressures while the body cavity can accept up to 150% rated working pressure. Care must be taken not to damage the seal faces and that they are clean for assembly. After pressure tests, with all test pressure relieved, the body cavity should be completely drained via the attached piping system to prevent corrosion. The valve may then be placed in the required operating position.

### HORIZONTAL INSTALLATION

When installing the swing check valve in the horizontal position, install the valve with the arrow mark on the body pointing in the direction of flow and the cover side up.

- ▶ **OPERATION**  
Flow through the valve (in the direction of the arrow mark) forces the clapper to lift fully. The clapper seals the valve when the flow is reversed. Gravity causes the clapper to swing closed when no flow is present.

### VERTICAL INSTALLATION

When installing the swing check valve in vertical piping, install the valve with the arrow mark on the body pointed in the upward direction. Upward flow through the valve will cause the clapper to swing open. This valve cannot be used with vertical downward flow.

- ▶ **OPERATION**  
If there is no flow through the piping, gravity will keep the clapper in the closed position. Flow through the piping in the upward direction will cause the clapper to swing open. When the flow is reversed, the flow and weight of the clapper will automatically close the valve.

## MAINTENANCE



**CAUTION:** Safety practices for pressurized equipment must be followed and address hazards inherent in pressurized systems. Extreme caution and safety procedures are to be exercised whenever valves, or fittings on a valve, are serviced or maintained.



### DISASSEMBLY:

No special tools are required to disassemble the valve. **With all pressure removed from the associated piping system**, the valves can be serviced in-line or offline.

During in-line maintenance, the swing check valve should be isolated from and relieved of all pressure on both the upstream and downstream sides. Ensure all line pressure is relieved before removing the plug on the cover. **Exercise extreme caution** when removing the plug on the cover. Any residual pressure can cause the plug to eject unsafely from the cover. Drain the valve fully through the piping system. Remove the cover, clapper, and hanger (Figure 1).

For offline maintenance, the valve should be removed from the pipeline.

### INSPECTION

Inspect the clapper and body seating surface for possible scoring marks or damage. These surfaces must be smooth. During maintenance, replace the clapper seal with a new seal. Inspect the cover O-ring seal for damage. Generally, the cover O-ring will last longer than the clapper seal.

### REASSEMBLY

Reassemble the valve in accordance with the following instructions. See Figure 1 (page 7):

1. INSTALL SEAL, 7, INTO CLAPPER 4.
2. INSTALL CLAPPER, 4, INTO HANGER, 5
3. INSTALL HANGER, 5, WITH CLAPPER, 4, INTO BODY, 1.
4. INSTALL SEAL, 6, INTO COVER, 2. LUBRICATE THREADS WITH TS-115 LUBRICANT.
5. THREAD COVER, 2, INTO BODY, 1.
6. TIGHTEN COVER, 2, ACCORDING TO CHART ON PAGE 7.
7. WRAP PIPE PLUG, 3, WITH PTFE TAPE 1-2 TURNS (PTFE PASTE MAY ALSO BE USED), AND INSTALL INTO COVER 2.
8. ENSURE THAT THE CLAPPER SWINGS FREELY INSIDE THE BODY, IS FREE OF OBSTRUCTIONS AND WILL CLOSE WITHOUT BINDING.

Figure 1:

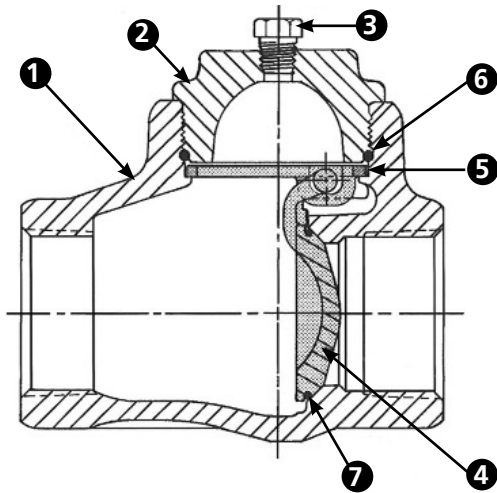

BODY / COVER MATERIAL		
	DUCTILE IRON	WCC, LCC, CF8M, ALUMINUM BRONZE
SIZE	TORQUE FT-LBF.	TORQUE FT-LBF.
1-1/2 & 2	116-128	234-257
3	143-157	174-201
4	114-125	232-255

## MAINTENANCE SCHEDULE

The frequency of the maintenance depends on the service conditions. Please contact the factory regarding the maintenance schedule for particular service conditions.

## RECOMMENDED SPARE PARTS

RECOMMENDED SPARE PARTS LIST GUIDE	
QTY. OF VALVES	REPAIR KIT
10	1
25	1
50	2
100	3

REPAIR KIT CONTENTS	
PART NAME	QUANTITY
Cover O-Ring	1
Clapper Seal	1
Clapper	1



**VALVES & MEASUREMENT**  
**3250 Briarpark Drive, Suite 300**  
**Houston, TX 77042**  
**USA Toll 800 323 9160**

For the most current contact and location information go to: [www.c-a-m.com](http://www.c-a-m.com)