



Rupture Pin[®] A BRAND of _____

Taylor Valve Technology[®]

GET THE **POWER** OF THE PIN

MODEL HPRV

High Pressure Relief Valve



FROM THE
CREATORS
OF THE
Original
BUCKLING
PIN
VALVE

Get Better Performance
and Longer Life!

Lower your Downtime
and Save Money!

Model HPRV

WWW.TAYLORVALVE.COM

SINCE 1958

“POCO” Pin Design Variation

This intelligent design allows the user to change the set pressure of the valve by simply changing pins. This is done by affixing pin spacers on each end of the Rupture Pin while keeping the overall length of the pin assembly constant.

Advantages

3" 1502 hammer unions.

Relief settings from 7,000 to 15,000 PSI with POCO set pressure pins.

Change the settings by changing the pin. The set pressure is shown on the pin label. The 3" Model HPRV valves use interchangeable pins. In addition, the pins are color-coded accordingly.

Reliable settings. Plant set pressure of +/- 5%* accuracy.

Simple dependable operation.

One moving part.

Fatigue and pulsation are not factors that affect the set pressure of the valve.

Reaches open position in milliseconds.

Provides a bubble-tight seal to set point.

Stainless-steel seat and piston are standard.

Greater washout resistance with no direct impingement on the seat, piston or seal.

Field repairable.

Visual indication of opening.

Unaffected by changing ambient temperatures on the pin.

Pin cannot fatigue and buckle early.

No environmental exposure to process fluids.



COLOR CODED PINS

Pins for the Frac Valve are color coded to show each individual set pressure.

HIGH PRESSURE RELIEF VALVES - “POCO” PIN CHART

PIN TYPE	SIZE	COLOR
HPRV - 7,000 PSI	3"	GRAY GOLD
HPRV - 7,500 PSI	3"	GRAY LT. BLUE
HPRV - 8,000 PSI	3"	GRAY OLIVE
HPRV - 8,500 PSI	3"	GRAY PURPLE
HPRV - 9,000 PSI	3"	GRAY YELLOW
HPRV - 9,500 PSI	3"	GRAY GREEN
HPRV - 10,000 PSI	3"	GRAY DK. BLUE
HPRV - 10,500 PS	3"	GRAY TAN
HPRV - 11,000 PSI	3"	GRAY ORANGE
HPRV - 11,500 PSI	3"	GRAY BRONZE
HPRV - 12,000 PSI	3"	GRAY PINK
HPRV - 12,500 PSI	3"	GRAY RED
HPRV - 13,000 PSI	3"	GRAY DK. GREEN
HPRV - 13,500 PSI	3"	GRAY BROWN
HPRV - 14,000 PSI	3"	GRAY FUCHSIA
HPRV - 14,500 PSI	3"	GRAY IVORY
HPRV - 15,000 PSI	3"	GRAY AQUA

* +/- 8% when in service due to varying process conditions.

— The Superior —
High Pressure
 Relief Valve

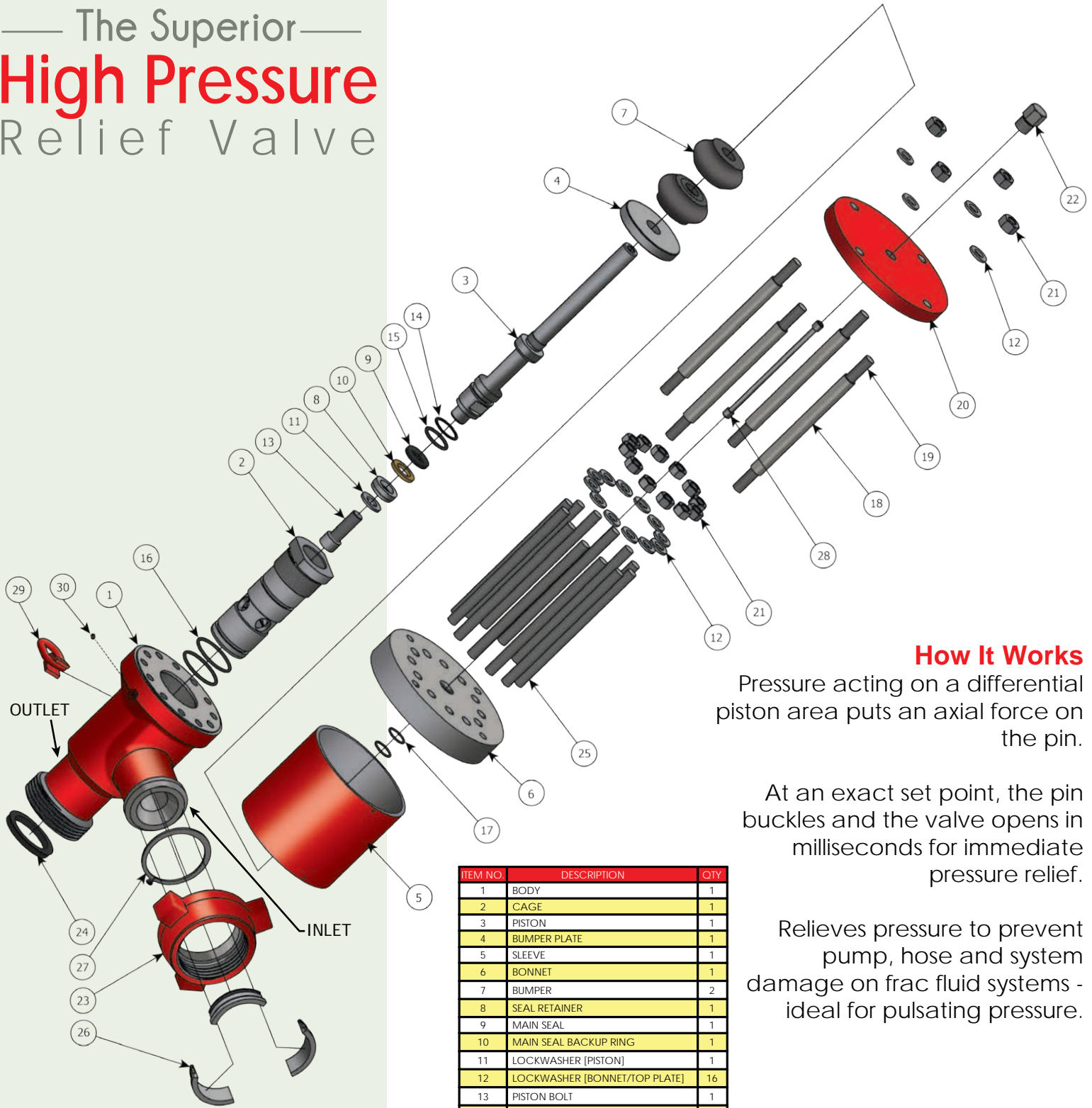

How It Works

Pressure acting on a differential piston area puts an axial force on the pin.

At an exact set point, the pin buckles and the valve opens in milliseconds for immediate pressure relief.

Relieves pressure to prevent pump, hose and system damage on frac fluid systems - ideal for pulsating pressure.

ITEM NO.	DESCRIPTION	QTY
1	BODY	1
2	CAGE	1
3	PISTON	1
4	BUMPER PLATE	1
5	SLEEVE	1
6	BONNET	1
7	BUMPER	2
8	SEAL RETAINER	1
9	MAIN SEAL	1
10	MAIN SEAL BACKUP RING	1
11	LOCKWASHER [PISTON]	1
12	LOCKWASHER [BONNET/TOP PLATE]	16
13	PISTON BOLT	1
14	BACK-UP RING [PISTON]	1
15	O-RING [PISTON]	1
16	O-RING [CAGE]	2
17	O-RING [STEM]	2
18	SPACER	4
19	POST	4
20	TOP PLATE	1
21	HEX NUT [BONNET/TOP PLATE]	16
22	HOLDING NUT	1
23	HAMMER UNION NUT	1
24	HAMMER UNION SEAL	1
25	BONNET STUD	12
26	HAMMER UNION RETAINER SEGMENT	3
27	HAMMER UNION RETAINING RING	1
28	POCO PIN	1
29	LIFTING LUG	1
30	GREASE FITTING	1



OPERATION

In the closed position, an elastomer seal contacts a machined, stainless-steel piston seat for a bubble-tight shut off.

Closed

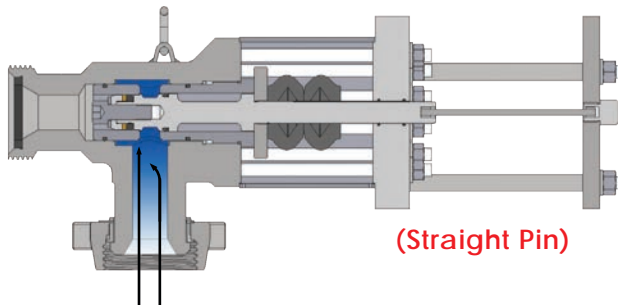

STANDARD MATERIALS

Model HPRV: AISI 4130, Forged Body with stainless-steel trim. Other materials optional.
Fluid compatible seals.

When the pin buckles, the piston moves fully open in milliseconds to a protected position to allow full flow pressure relief.

Open

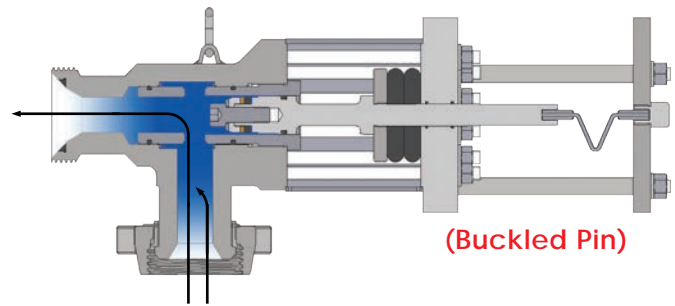

CONNECTIONS

Standard 1502H X 1502T connections available.

CERTIFICATIONS

Available with domestic offshore and international certifications and standards upon order request.

**Ready to drill FASTER & SAFER with
LESS DOWNTIME than your competition?
Let's get you using the best HPRV valve today!
Call us at:**

OPTIONS

1. STAINLESS-STEEL SAFETY CAGE
2. PIN CONTAINER
3. PROXIMITY SENSOR

