

AVENGER™ 33M

Particulate & Coalescing Filter



Avenger™ Model 33M Installation & Operation Instructions

Manufacturing Contact Information

A+ Corporation, LLC *Call for expert product application assistance:*
41041 Black Bayou Rd. Phone: (225)-644-5255 Website: www.geniefilters.com
Gonzales, LA 70737 Fax: (225)-644-3975 E-mail: sales@geniefilters.com

Safety Warnings



- ▶ For models containing Liquid Block™: Slowly open the supply pressure so that the minimum differential pressure required to shut-off the Liquid Block™ is not met or exceeded..
- ▶ Valve off the sample flow before installation.
- ▶ Do not exceed any equipment pressure ratings.

Tools Required

- ▶ Screwdriver for mounting bracket to panel.

Technical Specifications

Technical Specifications	
Maximum pressure rating	1,000 psig (68.9 barg)
Maximum Liquid Block™ valve auto-reset pressure	85 psig (5.8 barg) Slowly open the supply pressure so that the minimum differential pressure required to shut off the Liquid Block™ is not met or exceeded
Maximum temperatures	Type 6 membrane: 185°F (85°C) *Type 7 membrane: 300°F (149°C) * Actual limit depends on sealing material chosen. Refer to Temperature Range Comparison Chart.
Maximum Recommended Flow Rate Results in approx. 2 PSI pressure differential. For higher flow rates, contact the factory.	Type 6 Best Rejection: 4.7 SLPM (10 SCFH) Type 7 Highest Temps: 13 SLPM (27 SCFH)
Element size	Outside Diameter: ~ 1.4" Inside Diameter: ~ 1.0" Length: ~ 2.5"
Port sizes	Inlet, Outlet, & Bypass: 1/2" female NPT Gauge: 1/4" female NPT
Number of ports	5
Internal volume	200 cc
Wetted materials	Machined parts: 316/316L stainless steel / ISO 15156-3 compliant All other metal parts: stainless steel / ISO 15156-3 compliant Sealing material: User defined Membrane: inert

Dimensions

Back View

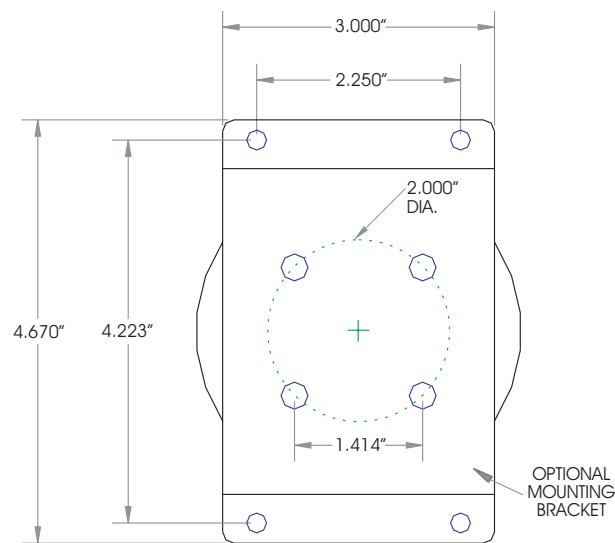

Side View

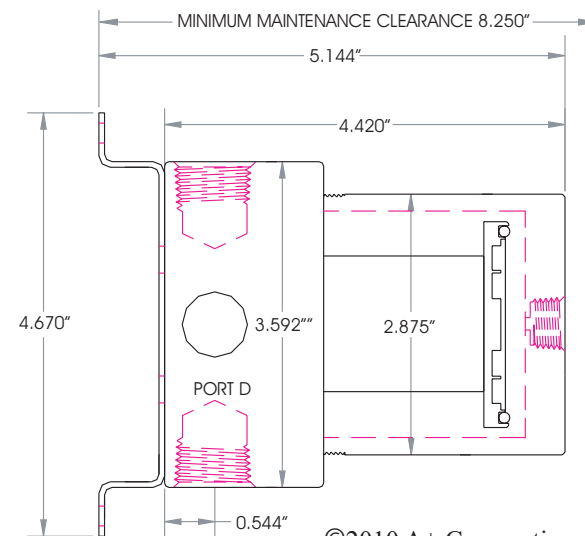

Installation Instructions

Install the mounting bracket onto the Avenger Model 33M or 38M as per the Mounting Bracket Installation Instructions included in A+ Corporation Mounting Bracket Kit P/N 33-509SS for Model 33M or P/N 38-509SS for Model 38M. Aftermarket brackets may be mounted as per the mounting diagrams below. Mount the Avenger horizontally as shown in the diagram. Lock washers may be used on the lower 10-32 screws to tilt the filter as shown to ensure that liquids drain properly. "Port D" should be facing down as shown. An optional downstream pressure gauge may be installed in "Port E" or it may be plugged. The Model 33M has 1/2" NPT ports (except for the 1/4" NPT gauge "Port E") and the Model 38M has 1/4" NPT ports. Refer to the "Application" for tubing connection instructions.

Application Drawing

Application #1: Coalescing Of Liquids And Removal Of Solids From Sample Gas- With Membrane



Horizontally Mounted

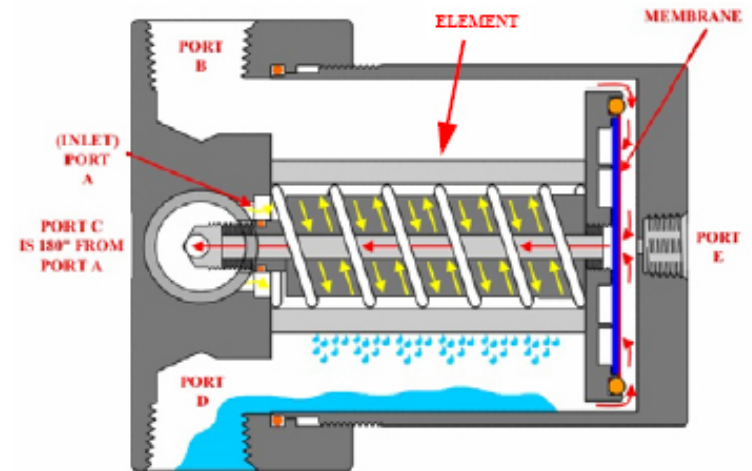
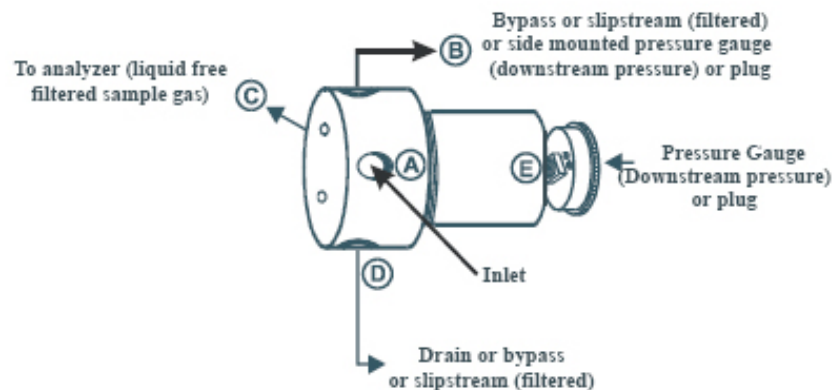

Model 33M or 38M mounts horizontally. Gas sample with entrained liquids and particulate enters port (A) and flows from the element interior to its exterior. A filtered bypass stream leaves port (D). Sample gas flows through the Membrane. Clean, liquid-free sample gas leaves Port (C). Liquid rejected by the membrane drains through Port (D)

* Flow is from element interior (center) to its exterior (outer)

Model Numbering & Additional Part Numbers

Model Numbering & Additional Part Numbers

Your model number is determined by your specific needs. Choose options below.

Sealing material	0 = Fluoroelastomer	1 = Perfluoroelastomer (other materials available upon request)
Element type	07CFS = 0.1 micron coalescer fluorocarbon	SS10 = 10 micron stainless steel
Membrane type	6 = Better Rejection; Rejects ALL types of liquids from vapor 7 = Highest Temps; Rejects ONLY high surface tension liquids	
Liquid Block™	S = No Liquid Block™	L = Liquid Block™
Mounting bracket accessory	Part # 33-509SS (sold separately)	

How to build the model number:

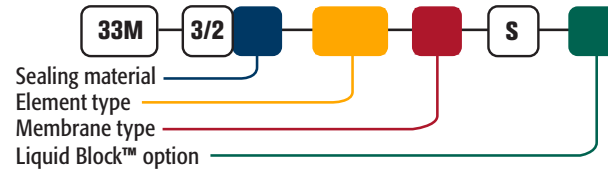

How to build the replacement o-ring kit number:

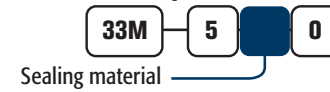

How to build the replacement filter element number:



How to build the replacement membrane kit number:

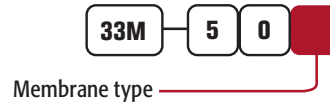

Replacement filter and membrane kits contain 5 each. O-ring replacement kit contains all assembly o-rings.

