

# FMG

## ROTARY METERS

THE BEST WAY TO PREDICT THE FUTURE IS TO CREATE IT

## FMR 150 SERIES

Designed to accurately and reliably meet the highest demands of gas flow measurement

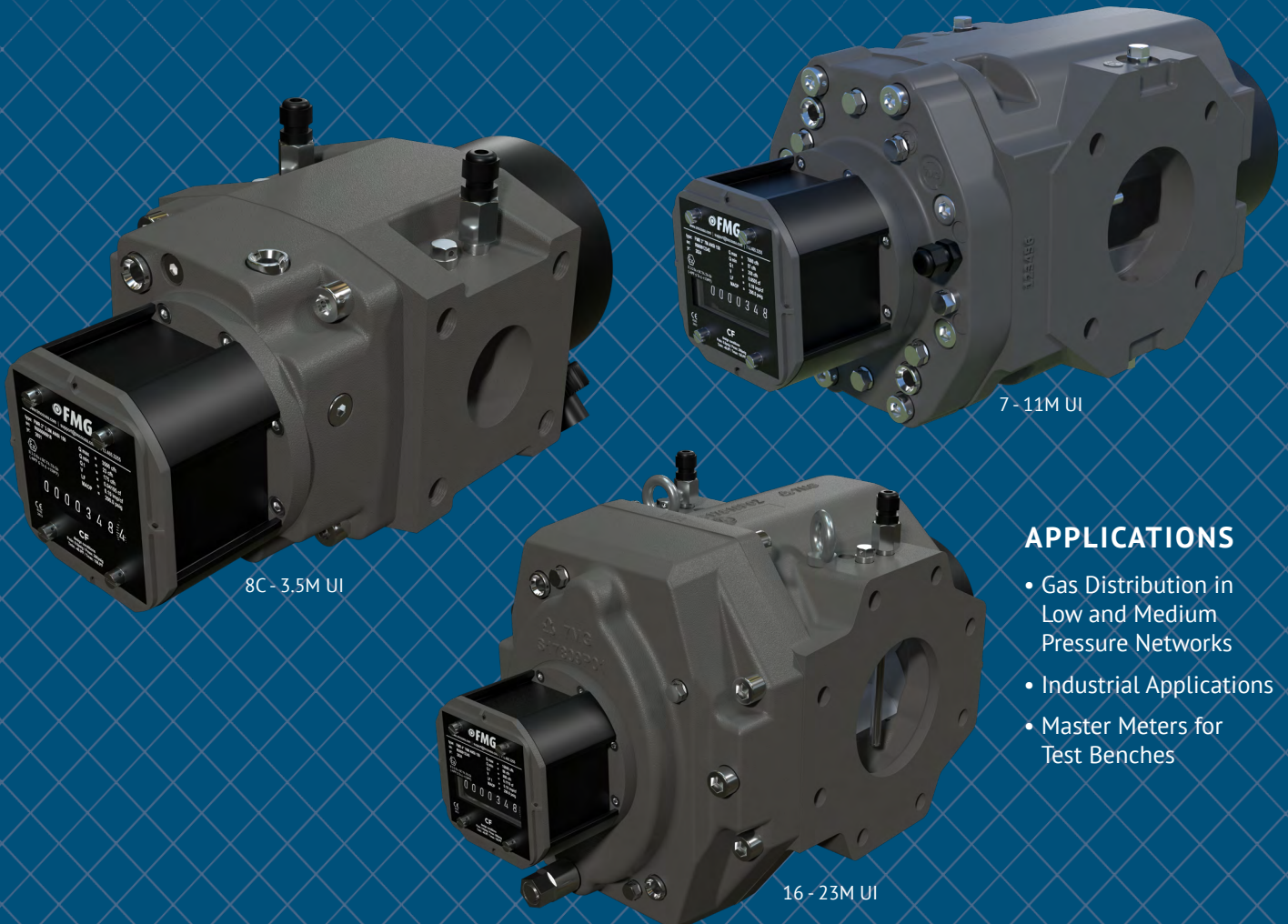

### APPLICATIONS

- Gas Distribution in Low and Medium Pressure Networks
- Industrial Applications
- Master Meters for Test Benches



[www.tmcousa.com](http://www.tmcousa.com) | [support@tmcousa.com](mailto:support@tmcousa.com) | 713.465.3255

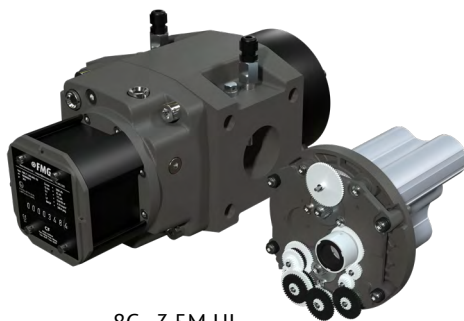

8C - 3.5M UI

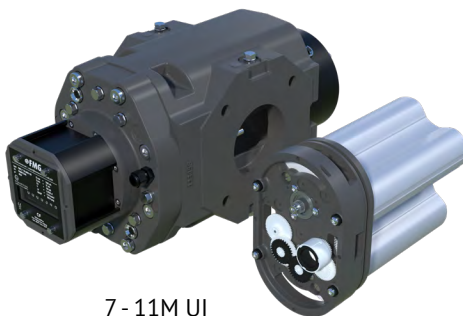

7 - 11M UI

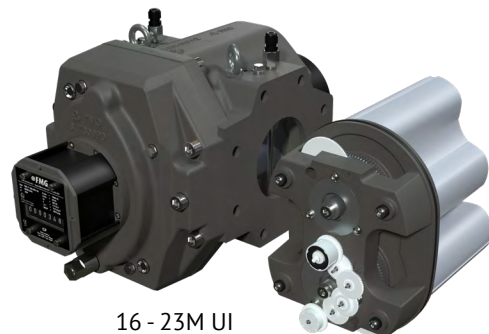

16 - 23M UI

## INTRODUCTION

**The Rotary Meter Series is designed to accurately and reliably meet the highest demands of gas flow measurement. \***

Meters are MID approved and fully comply with ANSI B109.3 and OIML R137. The compact exchangeable aluminum cartridge allows local repair and on-site cleaning.

The robust design of the casing and cartridge make the meter less sensitive to installation stresses caused by the connecting piping. The entire aluminum casing is designed for working pressures up to 290psig with a safety factor of 4.

Meters are more resistant to overload and pressure shocks because of the improved position of the main bearings and shafts and square impellers. The aluminum index and the protection of the standard installed, low frequency reed contact with the associated magnets, make the meter more resistant to tampering or manipulation.

## PRINCIPLE

**The FMR rotary gas meter is a positive displacement meter.**

The measurement of the gas is performed by two figure 8-shaped impellers (rotors) rotating within a measurement chamber. During a full revolution of the rotors, a fixed volume is displaced from the inlet to the outlet of the meter.

The number of revolutions represents the amount of volume passed. The volume is displayed on a direct reading mechanical counter/odometer. Several low and high frequency sensors can be used for flow computation or control purposes.

## ACCURACY

**Each FMR rotary meter is tested with atmospheric air to traceable VSL (formerly NMI) calibrated references.**

It has been proven – as part of the type approval testing – that the difference between the accuracy at atmospheric air and at high pressure natural gas is negligible.

*\* not suitable for oxygen services of any kind*

## ROBUST CONSTRUCTION

In the new cartridge design, the impellers, timing gears and bearings are fixed and positioned by a SynchroPlate.

With the SynchroPlate machined in one operation, tolerances are maintained at a very high level. This design allows for equally divided clearances between meter body and impellers, making the meters more dirt and debris resistant. The high strength shaft connecting the timing gear to the impeller overcomes flexing or bending of the impellers, making the meters more resistant to flow and pressure shocks. Severe intermittent on/off applications are typically handled without damage. A temporary overload of up to 500% of maximum capacity without degradation of the metrological quality is possible.



## LOW COST OF OWNERSHIP

All FMR Series rotary meters use a fix gear ratio in the index head (no adjustment gears) making it a “one-fits-all” design.

Together with the exchangeable cartridge design, the required parts for maintenance and repairs have been significantly lowered. The proprietary oiling system not only reduces wear and tear but keeps required oil changes over the meter’s lifespan to a minimum.



## SECURITY OF SUPPLY

Rotary gas meters are used in a wide variety of commercial and industrial applications due to their reliability and accuracy over an extremely large range.

However, rotary meters can become blocked due to dirt or other circumstance, stopping the gas supply unless precautions are taken. An **automatic bypass valve** integrated in the meter is the most convenient and reliable option. This provides security of supply as the bypass opens automatically when the differential pressure over the meter reaches a pre-set level (various springs for different set points are available).

The mechanism in the bypass works on a high force level (large diaphragm and strong springs) ensuring reliable operation over its expected lifetime. With two reed switches (normally one closed, one open) the status of the valve can be monitored by an EVC, a Flow Computer, RTU or Scada System.

It occasionally happens that an operator will open the inlet or outlet valves too fast, triggering the bypass and after depressurization, a removable plug provides access to the reset mechanism without special tools. To comply with local regulations, this plug can be wire sealed.

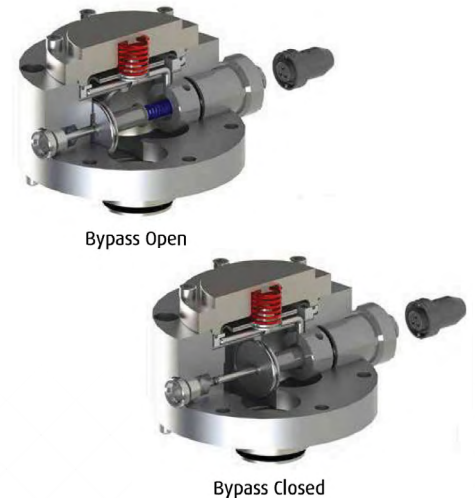

### BYPASS TECHNICAL DATA

#### MATERIALS

Pressure containing parts: Aluminum

Others: Stainless Steel

Diaphragm: NBR

Available set points: 1.5, 3.0, 6.0psi





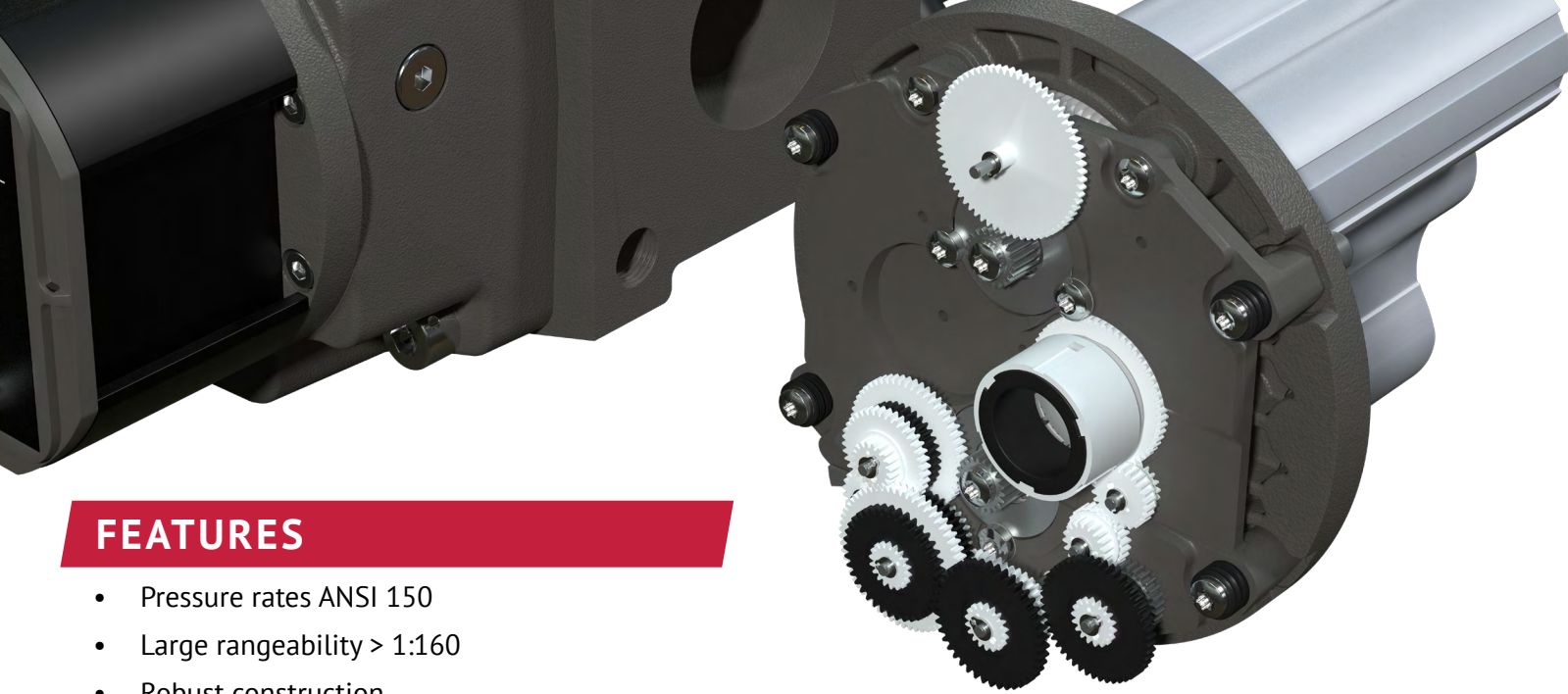

## FEATURES

- Pressure rates ANSI 150
- Large rangeability > 1:160
- Robust construction
- Square impeller technique
- Cartridge design
- Proprietary oiling system
- standard low frequency output (Reed contact or Wiegand)
- Optional high frequency output
- Multi-position
- Tamper proof, exchangeable index

## TECHNICAL SPECIFICATIONS

- Flow rates: 7cfh up to 23,000cfh
- Nominal diameters: 1-1/2" to 6"
- Flange connections: ANSI 150 FF, Threaded version  
1-1/2" NPT
- Max. operating pressure: 290psi
- Temperature range: -40°F to 158°F
- Mounting position: Horizontally or vertically
- Metrological approvals: OIML R137 1&2 (2014)  
EN12480:2002  
EN12480:2015  
MID 2014/32/EU
- Electrical Compliance: UL, FM, CSA, ATEX
- Body: ANSI B109.3, PED 2014/68/EU

## MATERIALS

- |                |                                |
|----------------|--------------------------------|
| • Body         | Aluminum                       |
| • Impellers    | Aluminum                       |
| • Cartridge    | Aluminum                       |
| • Shafts       | Stainless Steel                |
| • Gears        | Delrin                         |
| • Index Frame  | Aluminum                       |
| • Timing Gears | Carbon Steel                   |
| • Bearings     | Carbon Steel / Stainless Steel |
| • Index Cover  | Polycarbonate ECI              |

## DIMENSIONS

TECHNICAL DATA	UNITS	8C	1.5M	2.5M	3.5M	5.5M	7M	9M	11M	16M	23M
Base Rating (Qmax)	acfh	800	1500	2500	3500	5500	7000	9000	11000	16000	23000
	m <sup>3</sup> /h	25	40	65	100	160	250	250	250	400	650
Base Rating (Qmin)	acfh	23	23	23	23	35	56	56	56	88	141
	m <sup>3</sup> /h	0.65	0.65	0.65	0.65	1	1.6	1.6	1.6	2.5	4
Max Operating Pressure (MAOP)	psi	290	290	290	290	290	290	290	290	290	290
Pressure (MAOP)	bar	20	20	20	20	20	20	20	20	20	20
Rangeability +/- 1%	ratio	35:1	65:1	100:1	160:1	240:1	125:1	160:1	200:1	180:1	160:1
Start Rate	cfh	<1.77	<1.77	<1.77	<1.77	<2.47	<3.53	<3.53	<3.53	<5.30	<7.06
	m <sup>3</sup> /h	<0,05	<0,05	<0,05	<0,05	<0,07	<0,10	<0,10	<0,10	<0,15	<0,20
Stop Rate	cfh	<1.77	<1.77	<1.77	<1.77	<2.47	<3.53	<3.53	<3.53	<5.30	<7.06
	m <sup>3</sup> /h	<0,05	<0,05	<0,05	<0,05	<0,07	<0,10	<0,10	<0,10	<0,15	<0,20
Avg. Differential	in. w.c.	10	25	34	80	76	134	178	69	92	92
100%Flow	mbar	24	64	85	200	190	448	448	448	173	229
Drive Rate	cf.rev	10	10	10	10	10	10	10	10	100	100
	m <sup>3</sup> /rev	0.1	0.1	0.1	0.1	1	1	1	1	1	1
Nominal Pipe Size	in.	2	2	2	2	3	3	3 or 4	4	4	4 or 6
	DN	50	50	50	50	80	80	80 or 100	100	100	100 or 150
Flange-to-Flange	in.	6.75	6.75	6.75	6.75	6.75	6.75	6.75 or 9.50	9.50	9.50	9.50
	mm	171	171	171	171	171	171	171 or 241	241	241	241
Flange Connection	ANSI	150	150	150	150	150	150	150	150	150	150
Oil Capacity Horizontal	oz	1.048	1.048	1.048	1.048	1.048	1.251	1.251	1.251	4.024	4.024
Oil Capacity Vertical	oz	2.367	2.367	2.367	2.367	2.367	3.348	3.348	3.348	8.995	8.995



### FMR150 8C - 3.5M UNILF

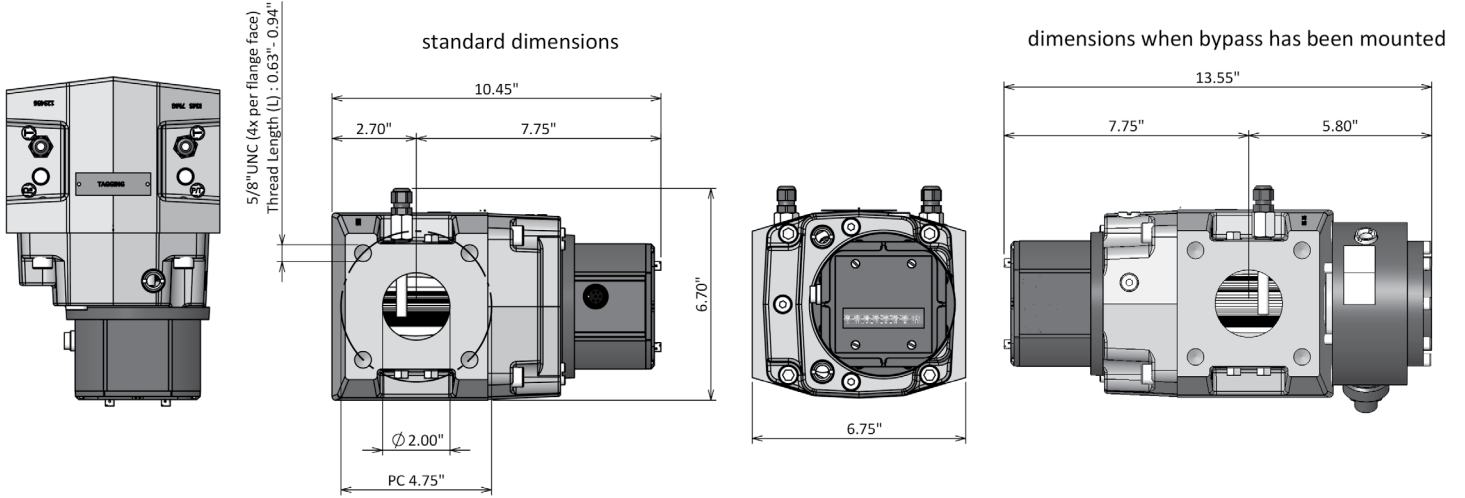

### FMR150 5.5M UNILF

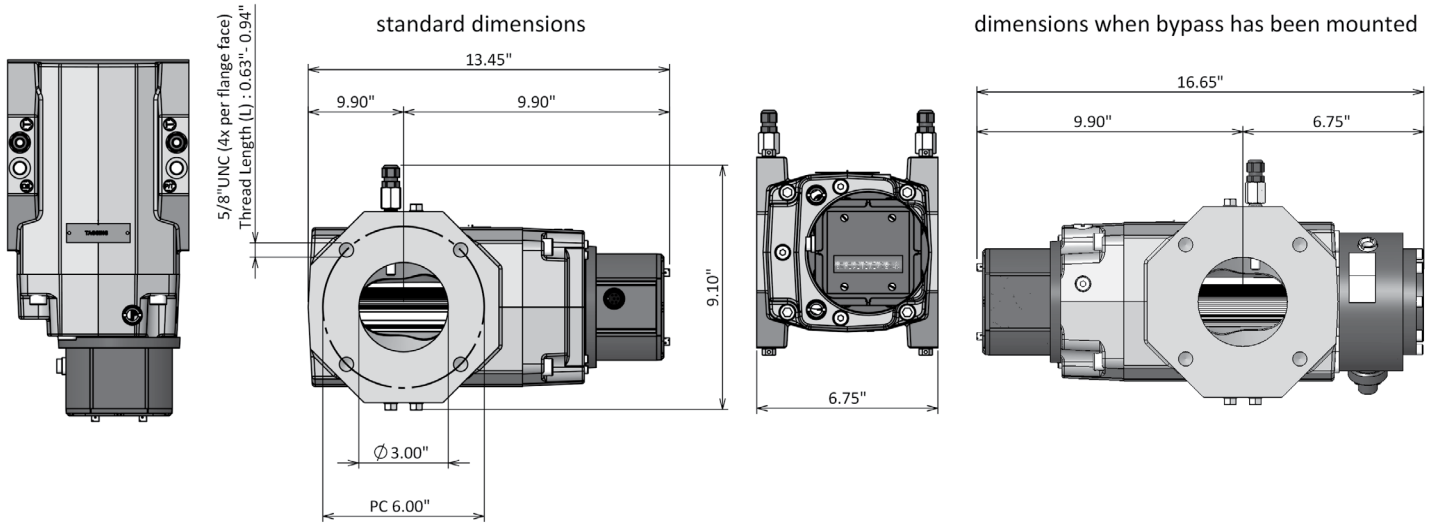

# Instrument Drive (ID)

## FMR150 8C - 3.5M ID

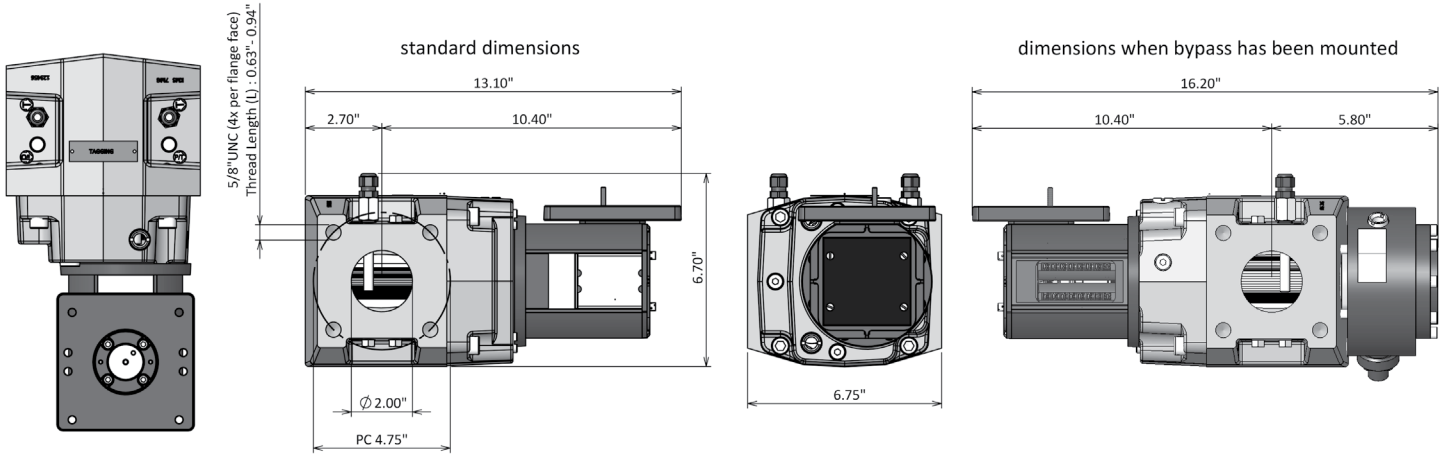

## FMR150 5.5M ID

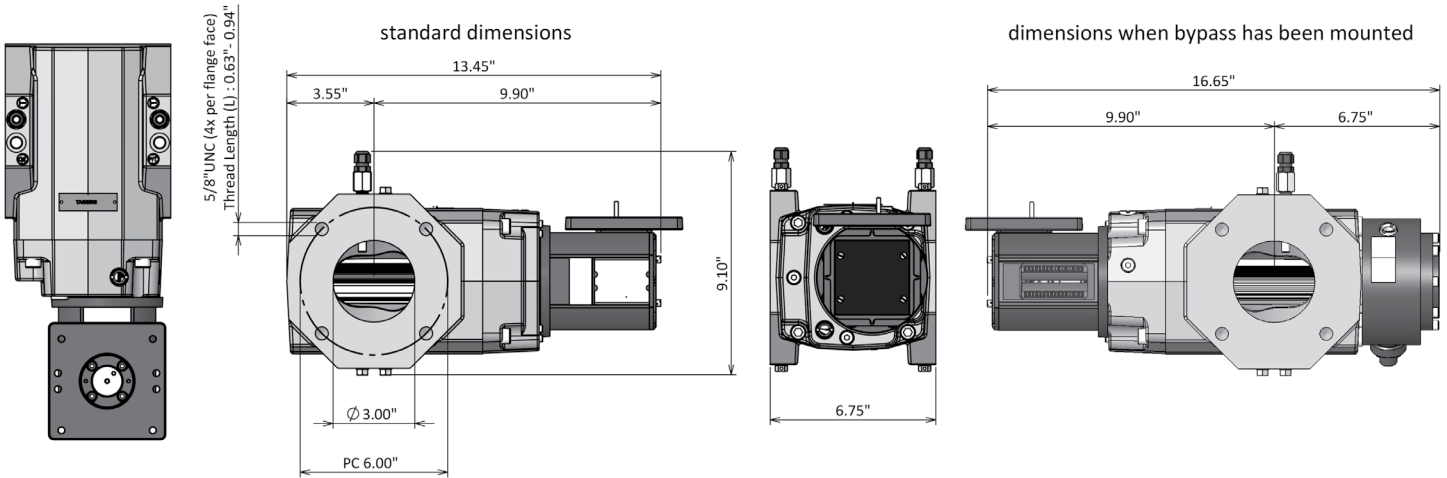



# Universal Index (LF included)

## FMR150 7M & 9M UNILF (6.75in body)

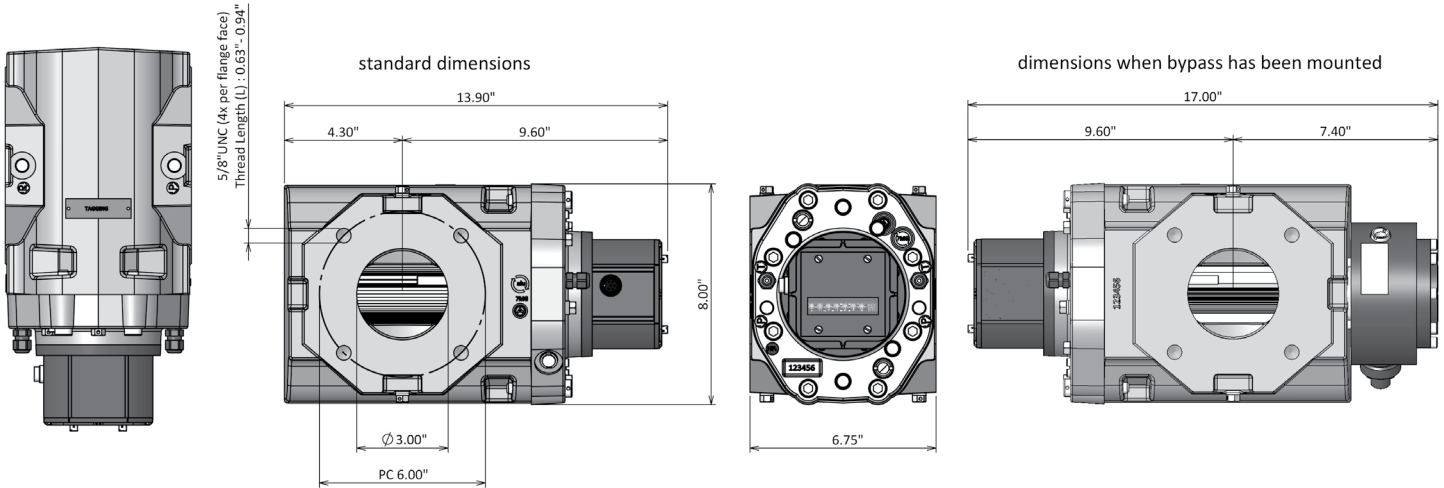

## FMR150 7M & 9M UNILF (9.50in body)

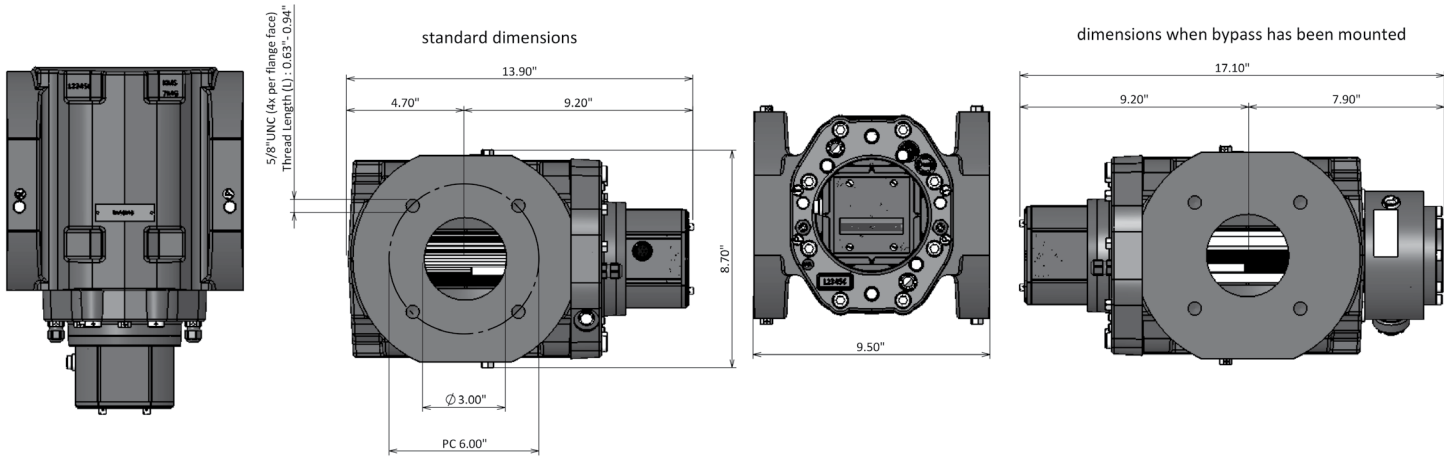

## FMR150 9M & 11M UNILF (9.50in body)

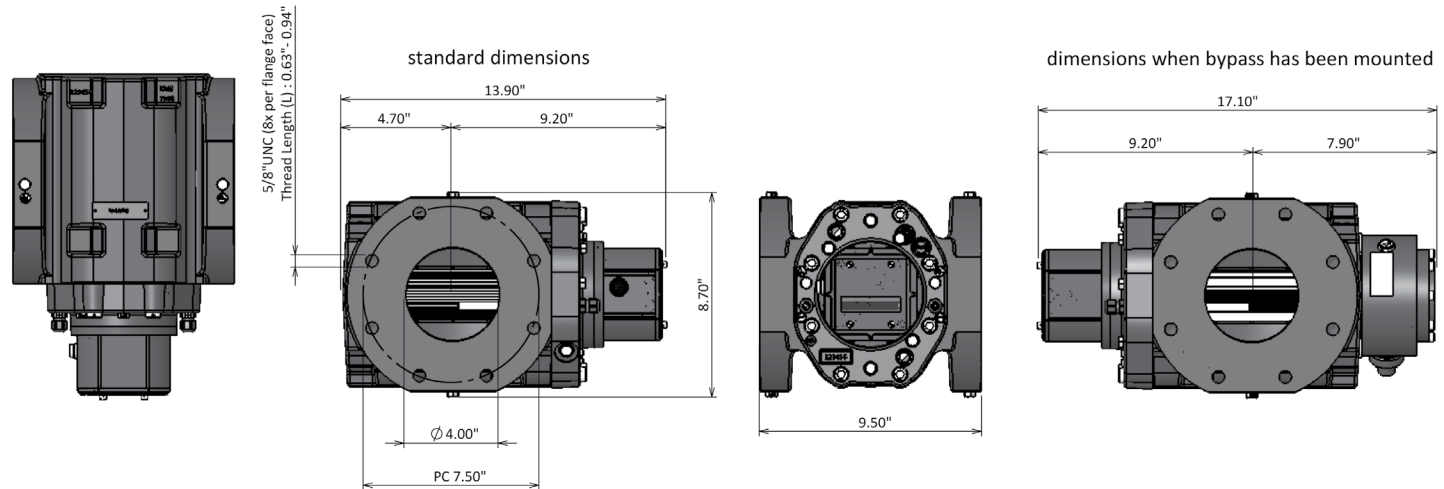



# Instrument Drive (ID)

## FMR150 7M & 9M ID (6.75in body)

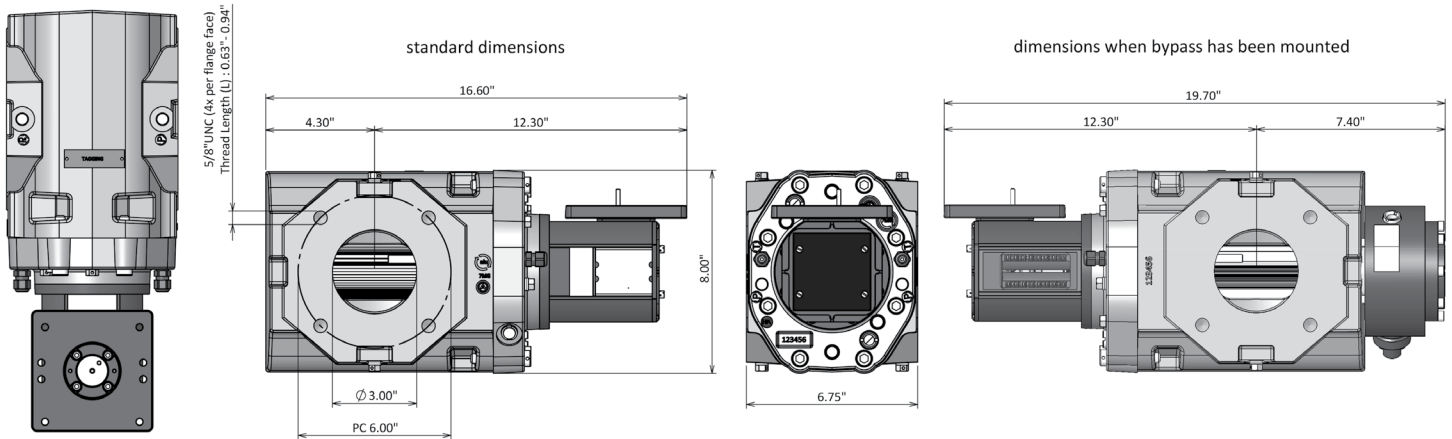

## FMR150 7M & 9M ID (9.50in body)

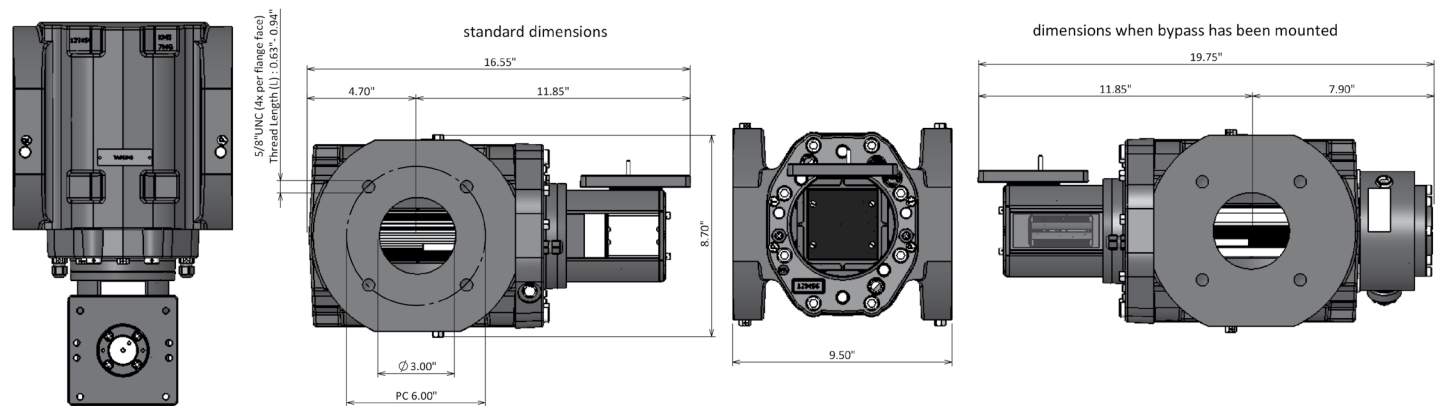

## FMR150 9M & 11M ID (9.50in body)

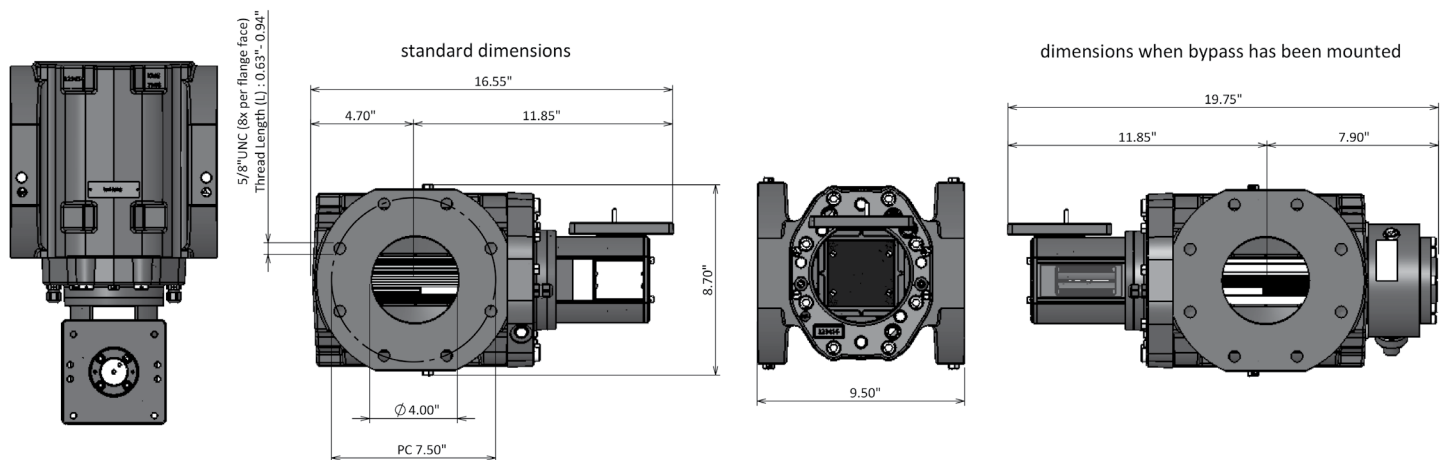

# Universal Index (LF included)

## FMR150 16M UNILF (9.50in body)

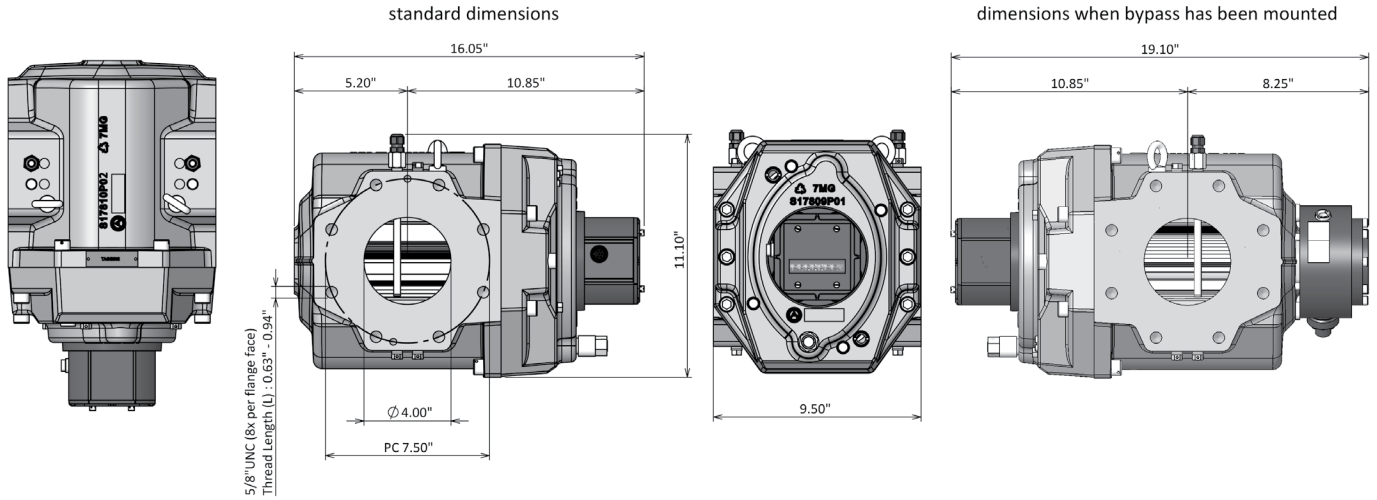

## FMR150 23M UNILF (4in pipe connection)

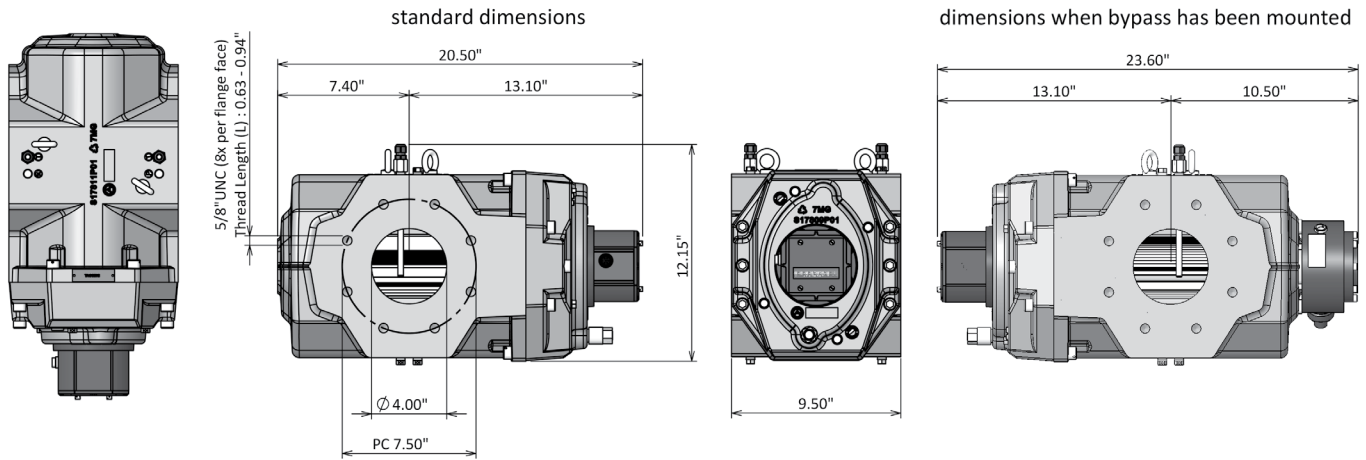

## FMR150 23M UNILF (6in pipe connection)

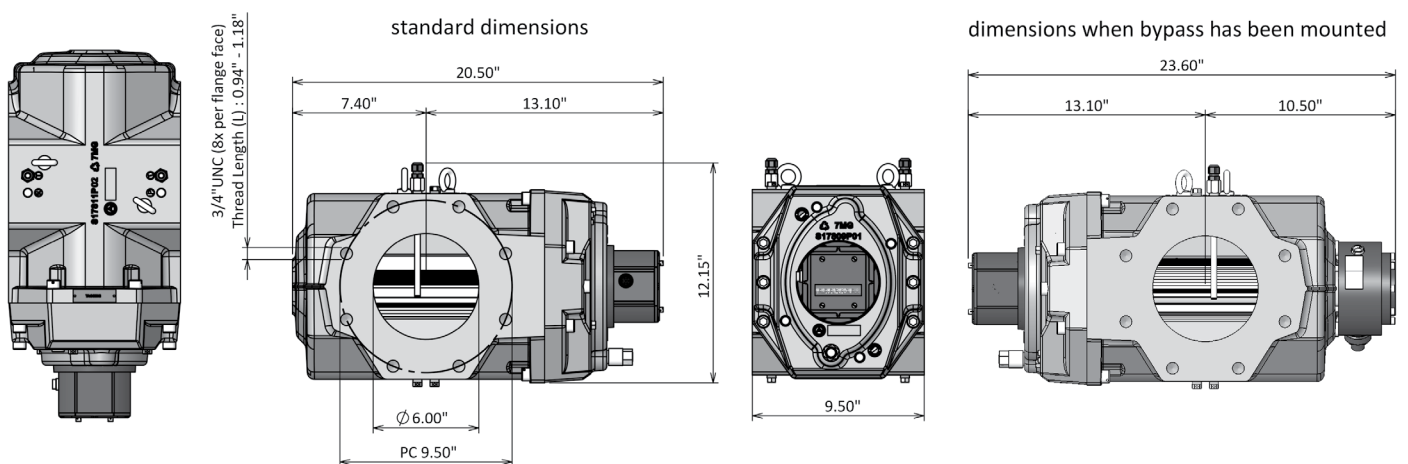

# Instrument Drive (ID)

## FMR150 16M ID (9.50in body)

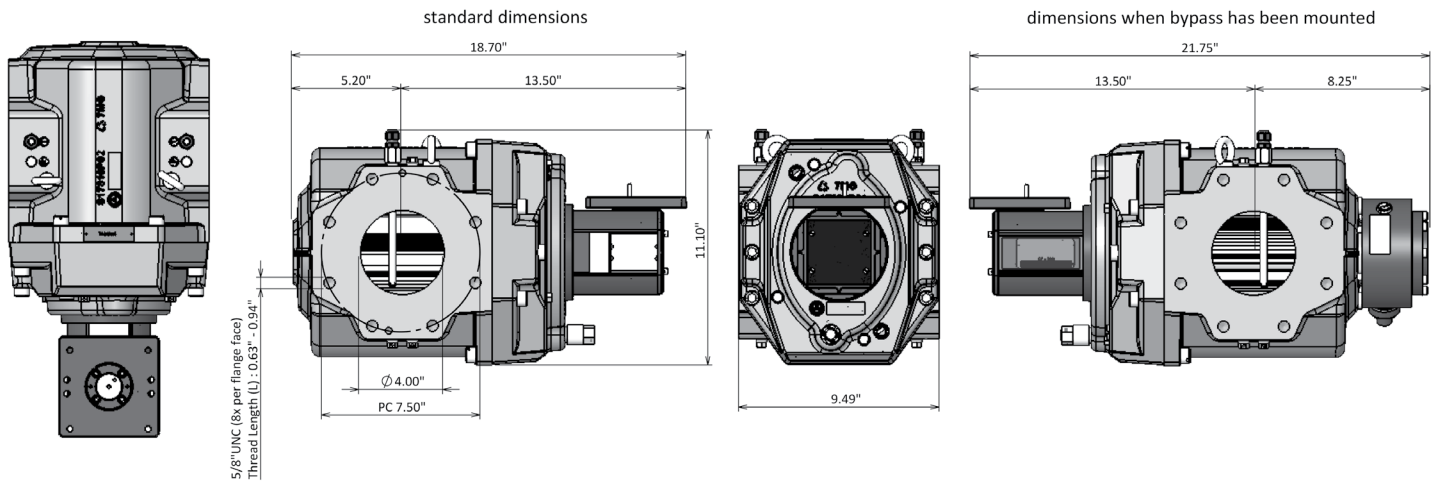

## FMR150 23M ID (4in pipe connection)

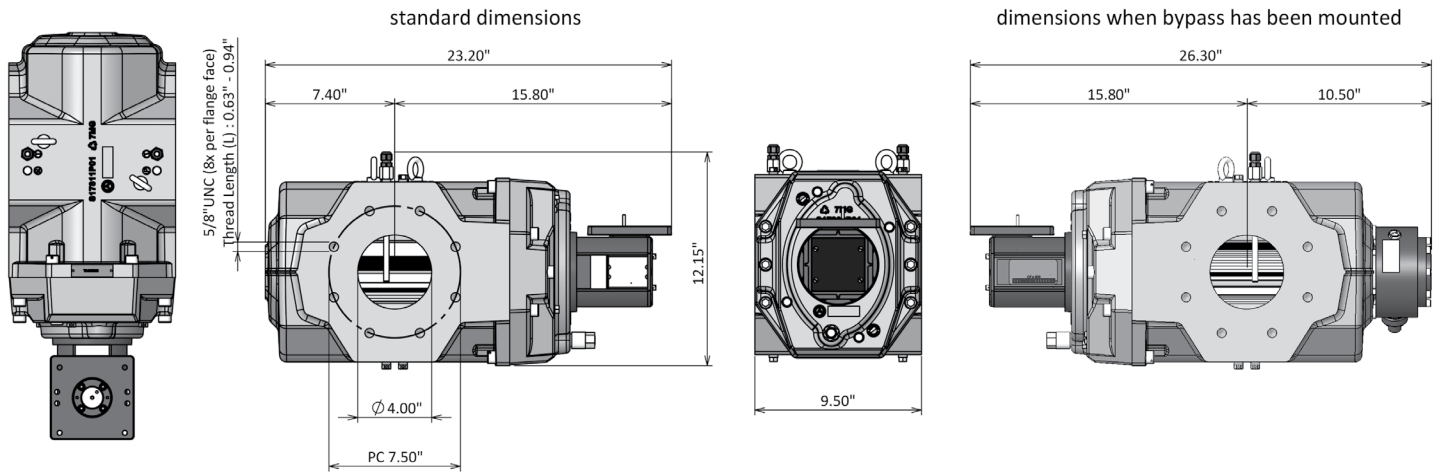

## FMR150 23M ID (6in pipe connection)

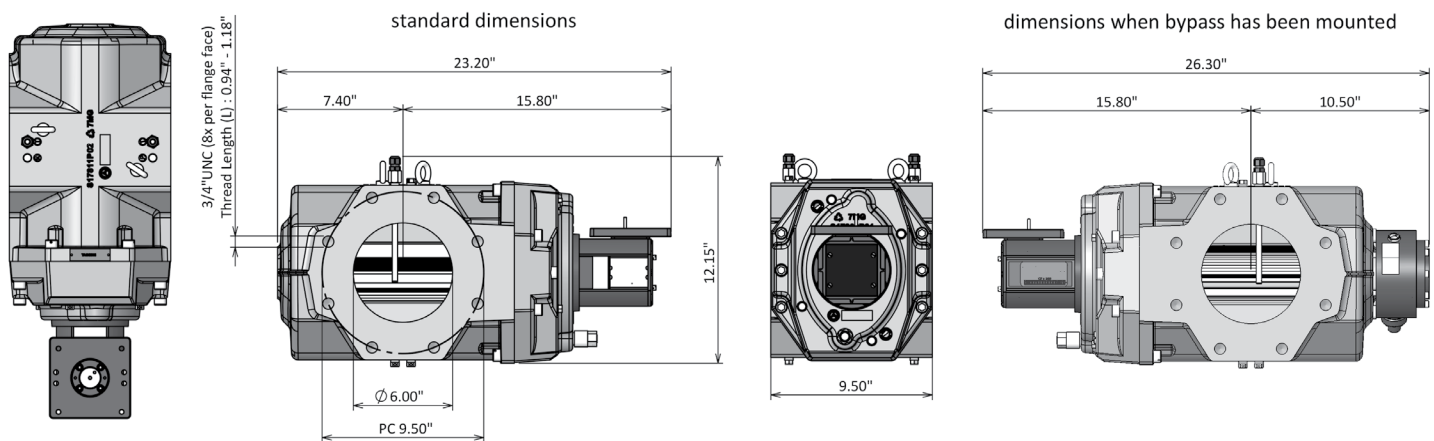

## CORRECTED CAPACITY AT METERING PRESSURE IN SCFH

MODEL	8C	1.5M	2.5M	3.5M	5.5M	7M	11M	16M	23M
RATING (acfh)	800	1500	2500	3500	5500	7000	11000	16000	23000
PSIG									
1	854	1,602	2,670	3,738	5,873	7,475	11,747	17,086	24,562
5	1,072	2,009	3,349	4,688	7,367	9,376	14,734	21,432	30,808
10	1,343	2,518	4,197	5,876	9,234	11,753	18,469	26,863	38,616
15	1,615	3,028	5,046	7,065	11,101	14,129	22,203	32,295	46,424
20	1,886	3,537	5,895	8,253	12,969	16,505	25,937	37,727	54,232
25	2,158	4,046	6,744	9,441	14,836	18,882	29,672	43,159	62,040
30	2,430	4,555	7,592	10,629	16,703	21,258	33,406	48,590	69,849
40	2,973	5,574	9,290	13,005	20,437	26,011	40,874	59,454	85,465
50	3,516	6,592	10,987	15,382	24,172	30,764	48,343	70,317	101,081
60	4,059	7,611	12,684	17,758	27,906	35,516	55,812	81,181	116,697
70	4,602	8,629	14,382	20,135	31,640	40,269	63,280	92,044	132,313
80	5,145	9,648	16,079	22,511	35,374	45,022	70,749	102,907	147,929
90	5,689	10,666	17,777	24,887	39,109	49,775	78,217	113,771	163,546
100	6,232	11,684	19,474	27,264	42,843	54,527	85,686	124,634	179,162
110	6,775	12,703	21,172	29,640	46,577	59,280	93,155	135,498	194,778
120	7,318	13,721	22,869	32,016	50,312	64,033	100,623	146,361	210,394
130	7,861	14,740	24,566	34,393	54,046	68,786	108,092	157,224	226,010
140	8,404	15,758	26,264	36,769	57,780	73,538	115,560	168,088	241,626
150	8,948	16,777	27,961	39,146	61,515	78,291	123,029	178,951	257,243
160	9,491	17,795	29,659	41,522	65,249	83,044	130,498	189,815	272,859
170	10,034	18,814	31,356	43,898	68,983	87,797	137,966	200,678	288,475
180	10,577	19,832	33,053	46,275	72,717	92,549	145,435	211,542	304,091
190	11,120	20,850	34,751	48,651	76,452	97,302	152,903	222,405	319,707
200	11,663	21,869	36,448	51,027	80,186	102,055	160,372	233,268	335,323
210	12,207	22,887	38,146	53,404	83,920	106,808	167,841	244,132	350,940
220	12,750	23,906	39,843	55,780	87,655	111,560	175,309	254,995	366,556
230	13,293	24,924	41,540	58,157	91,389	116,313	182,778	265,859	382,172
240	13,836	25,943	43,238	60,533	95,123	121,066	190,246	276,722	397,788
250	14,379	26,961	44,935	62,909	98,858	125,819	197,715	287,586	413,404
260	14,922	27,980	46,633	65,286	102,592	130,571	205,184	298,449	429,020
270	15,466	28,998	48,330	67,662	106,326	135,324	212,652	309,312	444,637
280	16,009	30,016	50,027	70,038	110,060	140,077	220,121	320,176	460,253
290	16,552	31,035	51,725	72,415	113,795	144,830	227,589	331,039	475,869



[www.tmcousa.com](http://www.tmcousa.com) | [support@tmcousa.com](mailto:support@tmcousa.com) | 713.465.3255

Copyright© 2024 TMCO, LLC All rights reserved. Specification may change without notice.

FMR-150SERIES 06-2024